

FREE

OFFICIAL VISITOR'S GUIDE



SERVICES • CAMPING • DINING • SHOPPING • EVENTS



JULY 22-28, 2024

Visitor's Guide Sponsored by
AIRCRAFT WHEEL & BRAKE
BY KAMAN

Cleveland
Wheels & Brakes

EAA AIRVENTURE
OSHKOSH
2024

**EXPERT INFORMATION FROM
THE NAME YOU TRUST**



Hosted by Bill Ross, A&P I/A

*2023 GAA National Aviation
Technician of the Year Award Winner!*

FORUM SCHEDULE 2024

Superior Air Parts AirVenture 2024 Forum Presentation Schedule

MONDAY

10:00am Engine Leaning Made Simple

TUESDAY

 8:00am Reducing Aircraft Engine Operational Cost & Improved Reliability

10:00am Setting Ring Gaps & Cylinder Life

WEDNESDAY

10:00am The Risks of Aircraft Engine Neglect

THURSDAY

10:00am Choosing the Right Aviation Mechanic or Engine Overhauler

FRIDAY

10:00am Aircraft Engine Compression Testing

SATURDAY

10:00am Aircraft Engine at TBO, Now What?

Each seminar qualifies for 1
hour of IA Renewal Credits



If you're an A&P, join us at
8:00am on Tuesday, July 23rd
for **TECH TUESDAY**

CELEBRATION WAY

**ALL FORUMS WILL BE HELD
AT THE SUPERIOR AIR PARTS
BOOTH #258**

264	263	262	261	260	259
253	254	255	256	257	258

**EXHIBIT
HANGAR
B**

SUPERIOR
AIR PARTS

FOR THE LATEST FORUM SCHEDULE AND
TIMES, VISIT
WWW.SUPERIORAIRPARTS.COM/FORUMS



3000 Poberezny Rd.
Oshkosh, WI 54902

CONTENTS

GENERAL INFORMATION

- 2** Grounds Access Policy
- 4** Visitor Services
- 10** Camping
- 20** Dining
- 24** Shopping
- 28** Neighborhoods
- 70** AirVenture Map
- 73** Schedule of Events
- 113** Local Advertising

EXHIBITORS

- 32** A to Z
- 58** Location Maps

LATEST NEWS & SCHEDULE

Schedule changes happen. Check the sources below for the latest information on AirVenture presentations, news, events, and daily air show schedules before heading to your event.

ONLINE

AirVenture.org/Schedule





APP



The official EAA AirVenture Oshkosh 2024 app, sponsored by Honeywell, for iOS and Android

SOCIAL MEDIA

Use #OSH24 to follow what the community is saying on these and other social media sites:

-  Facebook.com/EAA
-  X/Twitter.com/EAA
-  Instagram.com/EAA
-  TikTok.com/@eaa.oshkosh

PRINT

AirVenture Today, located in newspaper boxes around the grounds

RADIO

EAA Radio 1210 AM and 96.5 FM,
AirVenture.org/Radio

MOBILE PHONE

Text OSHFUN to 1-855-485-5674 to be the first to know about fun features and attractions at EAA AirVenture Oshkosh 2024 (maximum of 8 text messages per day). Text OSHALERT to 1-855-485-5674 to get automatic weather alerts when necessary. Unsubscribe at any time by texting STOP. Message and data rates may apply.



GROUNDS ACCESS

GROUNDS ACCESS RULES JULY 18-21

To improve safety, security, and mobility in the final hectic days before AirVenture opening day, these policies and procedures will be in place from Thursday, July 18, through Sunday, July 21.

GROUNDS ACCESS



Entry will be allowed to credentialed vehicles ONLY through Gate 33 (Waukau Avenue), Gate 37 (Knapp Street/Warbirds), and Gate 26 (Knapp Street/Theater in the Woods). Other vehicle gates will be closed. Noncredentialed vehicles are NOT allowed on the grounds, the same as during AirVenture week. Personal golf carts, scooters, bicycles, and other such vehicles are also prohibited. The restricted area (shown on map) will be enforced to ensure safety for everyone involved as AirVenture preparation is underway.

Exhibitors and vendors within the restricted area will receive special pre-event lanyard credentials. While early AirVenture attendees — such as those arriving with their aircraft — will not require wristbands until Sunday, July 21, they are asked to avoid entering the restricted area. Noncredentialed volunteers will be allowed onto the grounds ONLY to pick up credential packets from their chairmen. EAA security will be present in the restricted area. Noncredentialed vehicles will be asked to leave.

Exhibit Hangars and Aviation Gateway Park Setup Access: Thursday, July 18, through Sunday, July 21, there will be strict enforcement of access to Exhibit Hangars A-D and Aviation Gateway Park. Only credentialed exhibitors and vendors are allowed in these areas during setup hours from 8 a.m. until 6 p.m. on those days. At 6 p.m. sharp, doors in these areas will be locked.

Outdoor Exhibit Setup Access: From Thursday, July 18, through Sunday, July 21, there will be strict enforcement of access to outdoor exhibit areas. Access is limited to credentialed exhibitors and vendors, and only between the hours of 7 a.m. and 8 p.m.

Exhibit Show Hours: Exhibits are not open until Monday, July 22. Visitors on the grounds before that time are asked to give space to allow exhibitors to finish setting up their areas and to exercise caution anywhere around the outdoor exhibit areas due to the presence of equipment used to prepare the areas for the fun hustle and bustle of AirVenture.

RESTRICTED AREA MAP



★ PLATINUM LEVEL SUPPORTERS ★



★ ★ GOLD LEVEL SUPPORTERS ★ ★

DeltaHawk Engines ★ Epic Aircraft ★ Honda Aircraft Company ★ Honeywell Aerospace Technologies
 Lightspeed Aviation ★ Lycoming ★ Mars Wrigley ★ PenFed ★ Phillips 66 ★ Redbird Flight

★ ★ SILVER LEVEL SUPPORTERS ★ ★

Airbus ★ Aircraft Owners and Pilots Association (AOPA) ★ Aircraft Specialties Services ★ Cirrus Aircraft ★ Dynon
 Embry-Riddle Aeronautical University ★ Icom America ★ John Deere ★ Piper Aircraft, Inc.
 Pratt & Whitney, an RTX Business ★ Wipaire

★ ★ BRONZE LEVEL SUPPORTERS ★ ★

AeroShell ★ Air Wisconsin Airlines ★ ASA (Aviation Supplies & Academics) ★ Aspen Avionics ★ Blackhawk Aerospace
 Bose Aviation ★ Cleveland Wheels & Brakes by KAMAN ★ Co-Pilot Goose ★ Continental Aerospace Technologies
 Covington Aircraft ★ Crewchief Systems ★ Delta Air Lines ★ Electroair Acquisition Corporation ★ GE Aerospace
 Green Bay Austin Straubel Int. Airport ★ Gulf Coast Avionics / Pacific Coast Avionics ★ Gulfstream Aerospace Corporation
 Hangar 22 Coffee ★ Hartzell Engine Tech ★ Hartzell Propeller ★ Horizon Hobby ★ Jani-King ★ JP Instruments
 Lincoln Electric ★ magniX ★ McFarlane Aviation Products ★ NATCA ★ Pepsi ★ Piedmont Airlines
 Pilatus Business Aircraft Ltd ★ Poly Fiber, Inc ★ PowerLift Hydraulic Doors ★ Red Box Tools and Foam / Priceless Tugs
 Rotax iService and Training Centres ★ Siemens Digital Industry Software ★ SiriusXM Aviation ★ Skyrise
 Southwest Airlines ★ Superflite ★ Superior Air Parts, Inc. ★ SureFly Electronic Ignition ★ Tecnam ★ Tempest Aero Group
 True Blue Power ★ uAvionix ★ United Airlines ★ Van's Aircraft ★ WACO Aircraft Corporation / Junkers Aircraft
 Williams International ★ Wing Aviation ★ Women in Aviation International (WAI) ★ Zenith Aircraft

★ ★ COPPER LEVEL SUPPORTERS ★ ★

American Airlines ★ B & C Specialty Products Inc. ★ CAE ★ DATC ★ Flight Outfitters ★ Goodyear Tire & Rubber Company
 Oshkosh AeroTech ★ SOFTIE PARACHUTES by Para-Pernalia, Inc. ★ Starr Aviation ★ U.S. Air Force
 UND Aerospace ★ VOLARE HANGARS AT PEGASUS

★ ★ PATRON LEVEL SUPPORTERS ★ ★

4imprint ★ Arena Americas ★ David Clark Company ★ Endeavor Air ★ EnerSys® ★ FliteTest
 General Aviation Manufacturers Association (GAMA) ★ GES ★ Honda Power Equipment ★ JSfirm.com ★ MATCO ALS
 Ninety-Nines, Inc (The) ★ Pilotsmith ★ Scheme Designers, Inc ★ Target Oshkosh ★ Walkabout Hats ★ WILCO
 Wisconsin Imaging, LLC ★ X-Plane

VISITOR SERVICES

NOTICE TO AIRVENTURE ATTENDEES

Snowbirds Crowd Line – Friday, Saturday, and Sunday, July 26-28

Attendees, volunteers, and pilots should be aware that the Snowbirds performances require a larger aerobatic box, necessitating a slight move of the crowd line to the west during the afternoon air shows on those days. Only essential, authorized air show personnel are permitted inside the box during the Snowbirds performance.

The Snowbirds crowd line will run the entire length of the flightline from Ultralights through Warbirds, in line with the existing speaker poles, about 120 feet west of the regular crowd burn line. This line will be clearly marked.

For air show spectators

Visitors will have access to the regular crowd line area until 1:15 p.m. on Friday and Saturday and until noon on Sunday. At those times, visitors must move back to behind the Snowbirds crowd line. AirVenture guests will not be allowed to leave chairs, blankets, coolers, or other items past the Snowbirds crowd line at any time on those days. Friday through Sunday, Wittman Road will be closed to all vehicular traffic, providing additional space for air show viewing.

For pilots and crew of aircraft parked on the flightline

After 1:15 p.m. on Friday and Saturday and noon on Sunday, pilots or crew of aircraft parked between the two crowd lines will be allowed in the area for a short time with a security escort to perform urgent, essential tasks. Everyone will need to be out of this area by 4:30 p.m. on Friday and Saturday and 2:45 p.m. on Sunday.

Full access will be restored after the completion of the Snowbirds performance on Friday, Saturday, and Sunday. Look for extensive signage on the grounds further explaining the areas and times covered by these necessary rules and guidelines.

AA/AL-ANON (F-8)

Baby Ace Tent in the Nature Center
Sun 7/21-Sun 7/28, 7-9 a.m.

AVIATION MUSEUM (B-8)

Sun 7/21-Wed 7/24 and Fri 7/26-Sat 7/27, 8 a.m.-6 p.m.; Thu 7/25, 8 a.m.-3 p.m.; Sun 7/28, 8 a.m.-4 p.m.

BABY DIAPER-CHANGING/NURSING ROOMS

- KidVenture (D-7)
- Next to First Aid building (K-10)

ATM



CAMP SCHOLLER

- Campground EAA Security Building (F-15; porch)
- Red One Market West (B-14)
- Red One Market Central (G-14)
- Red One Market Southwest (C-19)

AIRCRAFT CAMPING AREAS

- Hangar Café (L-15)
- Homebuilt Hangar (K-9; porch)
- Red One Market North 40 (H-4)
- Red One Market South 40 (L-24)
- Ultralight Barn (K-18)
- Ultralight Café (L-18)

AIRVENTURE GROUNDS

- All A&W locations
- Bus Park (G-11)
- Celebration Way – Concessions (I-13)
- EAA Aviation Museum (B-8; inside)
- EAA Wearhouse Merchandise (J-12)
- Fly Market (H-14; porch)
- KidVenture (D-7)
- Main Admission Gate (G-13)
- Tailwind Café (K-9)
- Twin Oaks (K-12)
- Vintage Tall Pines Café (L-15)
- Vintage Concession (K-14)
- Warbirds Store (L-6)

Plan Your Visit: Download the Mobile App

Create your customized EAA® AirVenture® Oshkosh™ experience.

Save your schedule and easily keep track of the speakers, forums, and workshops on your AirVenture 2024 must-see list!

Download now at EAA.org/App.

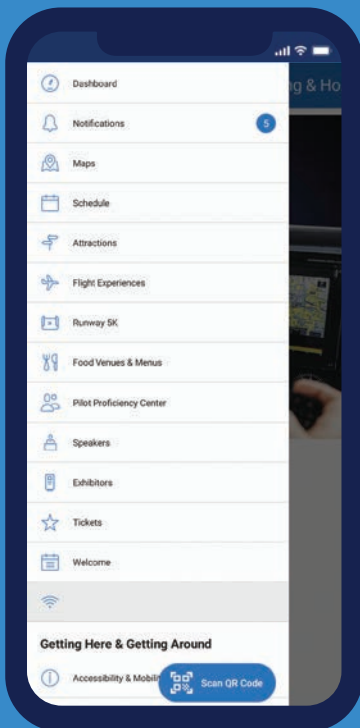

EAA AirVenture Oshkosh
2024 app is sponsored by:

Honeywell

VISITOR SERVICES

CAR TROUBLE

Report car problems to Security at 920-230-7754.

CHARGING STATIONS

Charging stations sponsored by PenFed can be found on the map on Page 70.

CHURCH SERVICES

Chaplain Services

Fergus Chapel (E-8), Sat 7/20-Sun 7/28

Nondenominational Service

Fergus Chapel (E-8), Sun 7/21, 8:30-9 a.m. and 9:30-10 a.m.; Sun 7/28, 8:30-9 a.m.

Fellowship of the Wing

Fergus Chapel (E-8), Mon 7/22-Sat 7/27, 7-7:45 a.m.

Jewish Shabbat Service

Fergus Chapel (E-8), Fri 7/26, 6-7 p.m.

Catholic Mass

- Theater in the Woods (J-14),
Sun 7/21, 10:15-11:15 a.m.;
Sun 7/28, 10:15-11:15 a.m.
- Forum Pavilion 7 (J-9), Sat 7/27, 6-7 p.m.

Protestant Service

Theater in the Woods (J-14),
Sun 7/21, 9:15-10 a.m.; Sun 7/28, 9:15-10 a.m.

Memorial Wall Dedication

Fergus Chapel Grounds (E-8), Sun 7/28, 10-11 a.m.

EMERGENCY AIRCRAFT REPAIR

Sat 7/20-Sat 7/27, 8 a.m.-5 p.m.; Sun 7/28, until early afternoon
Emergency aircraft repair is available near Vintage area camping (L-16). Call 920-230-7795 or contact the 24-hour hotline at 563-549-0855. Minor repairs are available on Fri 7/19.

FIRST AID SERVICES (K-10)

In an emergency, call 911.

Mon, Tue, Thu, Fri, 8 a.m.-7 p.m.
Wed and Sat 7/27, 8 a.m.-9 p.m.
Sun 7/28, 8 a.m.-3 p.m.



INFORMATION CENTERS ASSISTANCE CENTER MAIN GATE (G-13)

Mon 7/22-Sat 7/27, 7 a.m.-7 p.m.; Sun 7/28, 7 a.m.-2 p.m.

EAA CONVENTION HEADQUARTERS (J-11)

Sun 7/21-Sat 7/27, 8 a.m.-6 p.m.; Sun 7/28, 8 a.m.-5 p.m.

EAA MEMBER CENTER (K-13)

Sun 7/21-Sun 7/28, 8 a.m.-5 p.m.

COMMUNICATIONS CENTER (M-12)

Sun 7/21-Sat 7/27, 24 hours; Sun 7/28, until the end of the air show

INTERNATIONAL VISITORS TENT (K-12)

Mon 7/22-Sat 7/27, 8 a.m.-5 p.m.; Sun 7/28, 8 a.m.-noon

OSHKOSH VISITORS INFORMATION CENTER (J-11)

Mon 7/22, 8 a.m.-7 p.m.; Tue, Thu, Fri, 8 a.m.-5 p.m.;
Wed and Sat 7/27, 8 a.m.-8 p.m.; Sun 7/28, 8 a.m.-noon

LOST AND FOUND (J-11)

Mon 7/22-Sun 7/28, 8 a.m.-5 p.m.

SECURITY

EAA Security operates from July 18 at 5:30 a.m. to July 28 at 10:30 p.m. at 920-230-7754. The Winnebago County Sheriff's Office is on Waukau Avenue, west of the ATC tower (I-10).

SHIPPING (FOR VISITORS ONLY)

Inbound: Packages sent to you must include this label information:

- Your name
 - Cellphone number to contact during convention
 - C/O EAA AirVenture Oshkosh 2024
Global Experience Specialists (GES)
1001 W. Waukau Ave., Oshkosh, WI 54902
- Pick up shipments at the GES Service Center (I-11).

Outbound: Visit the UPS Store on the AirVenture grounds (I-11). Shipping services are offered Mon 7/22-Sun 7/28 8 a.m.-5 p.m. The U.S. Postal Service is off-site at 1025 W. 20th Ave., Oshkosh. U.S. postage stamps are available at the EAA Warehouse (J-12) and Museum Gift Shop (B-8).

Aviation Solutions

Engineered for Pilots & Support Teams

Icom provides innovative aviation solutions that are reliable and dependable on and off the ground. This is why pilots trust Icom.

- **Handhelds: IC-A25** and **IC-A16** Series
The perfect backup Comms.
- **Base: IC-A120B**
Perfect base station for home or airport communications. Mobile version available.
- **Panel Mount: IC-A220**
Easy to install even in tight configurations.

EAA AIRVENTURE
OSHKOSH
2024

Visit the Icom Booth #2027
July 22 – July 28, 2024



ADD BEFORE FLIGHT



www.icomamerica.com
insidesales@icomamerica.com

©2024 Icom America Inc.
The Icom logo is a registered trademark of Icom Inc. 43514



VISITOR SERVICES

TRANSLATION SERVICES

Language translation services are available at the International Visitors Tent (K-12) or by calling 920-230-7882. Hours: Mon 7/22-Sat 7/27, 8 a.m.-5 p.m.; Sun 7/28, 8 a.m.-noon

TRANSPORTATION

Bus Park (G-11)

Shuttle bus hours and stops:

- On-Site (sponsored by Blackhawk Aerospace) — Sun 7/21-Sat 7/27, 6:30 a.m.-11 p.m.; Sun 7/28, 6:30 a.m.-5 p.m.
Stops: EAA Aviation Museum, Pioneer Airport, KidVenture, Camp Scholler, South 40, North 40 perimeter road
- Seaplane Base — Sun 7/21, noon-8 p.m.; Mon 7/22-Sat 7/27, 8 a.m.-8 p.m.; Sun 7/28, 8 a.m.-noon (\$3 per round-trip rider)
Stops: Bus Park and south of the Ultralights area (M-23)
- Target — Fri 7/19-Sun 7/28, 7:30 a.m.-3:30 p.m.
Stops: Bus Park, Red One Market West, Target entrance

GO Transit (Oshkosh transit system)

Hours (departing from the Bus Park): Sun 7/21, 7:30 a.m.-7 p.m.; Mon 7/22-Sat 7/27, 7 a.m.-11 p.m.; Sun 7/28, 7 a.m.-5:30 p.m.

Locations: Round-trip bus service (\$5 each way) every half-hour to/from UW Oshkosh, Wittman Regional Airport, and the GO Transit downtown transit center. Visit [Bit.ly/EAABus](https://bit.ly/EAABus), or call 920-232-5340, for schedule and map information.

Kobussen Buses

Bus service to and from locations in Appleton, and bus and taxi-like services in Oshkosh. Call 920-422-0604 or visit the Kobussen Buses tent located at the Bus Park.

Uber/Lyft Drop-Off and Pickup

- Super 8/Friar Tuck's Pedestrian Gate (D-1)
- Foundation Road south of Gate 34 (H-10)
- Camp Scholler S Lot (A-15)
- South 40/Gate 19/Knapp Street and County Road N

WI-FI

Complimentary Wi-Fi hotspots are located throughout the grounds for internet access.

(Note: Roaming service is not available.)

Issues? Call the Wi-Fi help desk at 920-230-7831.



Shuttles (supported by Piper Aircraft)

Mon 7/22-Sat 7/27, 6:30 a.m.-11 p.m.; Sun 7/28, 6:30 a.m.-5 p.m. (unless noted)

- **Red Route:** Knapp Street from the North 40/Warbirds area, with stops at Warbirds, Forums, and Aircraft Spruce & Specialty Workshops Plaza.
- **Yellow Route:** North of Hangars A and C, with stops at the exhibit hangars to a pickup/drop-off area south of Hangar B, giving easy access to Camp Scholler.
- **Blue Route:** South of Hangar B to Wittman Road, through the Vintage area, to the Ultralights area, to the Seaplane Base shuttle stop and back.
- **Purple Route:** Runs the loop through Homebuilt Aircraft Camping along the airport service road, from Galatin Avenue near Aviation Gateway Park to the North 40 entrance. This route will operate ONLY during high-demand times (8-11 a.m. and 3-7 p.m.).
- **Express Routes (New):** One runs between the North 40 and Hangar C, the other between the South Tram Stop and Hangar B. There are no intermediate stops on either route. Express routes operate Monday through Saturday 8 a.m.-8 p.m., Sunday 8 a.m.-5 p.m.

VOLUNTEERING (G-14)

Hours: Mon 7/15-Sun 7/28, 8 a.m.-5 p.m.

Enhance your visit to AirVenture Oshkosh by volunteering, even for a few hours. Stop in the Camp Scholler Volunteer Center near Red One Market Central or visit EAA.org/Volunteer to learn about many behind-the-scenes opportunities.



Over 20 Years of Innovation
Flying in Over 25,000 Aircraft

FAA STC Approved for Over 600 Certified Aircraft Models
NEW 12" Display for Experimental and LSA Aircraft



There's a reason pilots...

FLYDYNON



HANGAR D: 4034 - 4035

SCAN TO DISCOVER MORE
DYNON.COM



PHONE DIRECTORY

In an emergency, dial 911.

Bus Park Tower (bus/taxi/limo info).....	920-230-7932
Camp Scholler Registration	920-230-7725
EAA Flightline Operations.....	920-230-7790
FAA Control Tower	920-424-8000
FBO Basler Flight Service.....	920-236-7827
First Aid, Camp Scholler.....	920-230-7807
Flight Service	800-992-7433
Homebuilders Headquarters.....	920-230-7799
North 40 Aircraft Camping/Parking.....	920-230-7727
Security.....	920-230-7754
Showplane Camping.....	920-230-7818
South 40 Aircraft Camping.....	920-230-7732
Ultralight Barn	920-230-7940
Warbirds Registration	920-230-7768
Wittman Regional Airport.....	920-236-4930

WEATHER INFORMATION

Local Weather Resources

Radio (including weather alerts):

- EAA FM 96.5 and AM 1210 (Oshkosh)
- AM 1490 WOSH (Oshkosh)
- AM 1280 WNAM (Nenah)
- AM 1450 KFIZ (Fond du Lac)
- NOAA Weather Radio (Winnebago County radio frequency 162.500)

OSHALERT TEXT MESSAGE WEATHER ALERT



Sign up to receive text message weather alerts for potential bad weather.

Text OSHALERT to 1-855-485-5674.

(Available for United States and its territories only.)

Weather Watch

A watch means that conditions are favorable for severe storm/tornado development.

- Secure items that could be blown away in high winds.
- Be prepared to unplug your electric cord from the electric pedestal.
- If camping by your aircraft, make sure it is tied down securely.

Weather Warning

A warning means that dangerous weather is threatening the area.

Severe Thunderstorm Warning

- Take shelter in your camper or vehicle.
- If a shelter or vehicle is not available, find a low spot away from trees, fences, and poles, but make sure the spot is not prone to flash flooding. If you cannot avoid trees, try to stay close to shorter trees. Cover your head with your hands and lie down on the ground.

Tornado Warning

- Find a ditch, depression, or low area and lie down, covering your head with your hands.
- As a last choice, secure yourself in your vehicle, with the vehicle running so the air bags can be deployed. Keep your head lower than the vehicle windows and covered.

Severe Weather Shelter

Should a weather emergency occur, anyone seeking shelter can go to the EAA Aviation Museum. If the weather emergency leads to an evacuation of the grounds, buses will transport those seeking shelter from all Red One Markets and Camp Scholler shower houses to the EAA Aviation Museum.

ATM LOCATIONS

- Camp Scholler Security & Assistance Center
- Red One Market
- Ultralight Barn
- Warbirds HQ
- EAA Aviation Museum
- Homebuilders HQ
- Seaplane Base
- Main Gate
- Bus Park

BICYCLE PARKING

Bicycles are allowed in the campgrounds, but they are not allowed on the convention site.

Bicycle corrals are located:

- North 40 Admissions Gate
- Main Gate Admissions (north side)
- West of Admissions Gate 27
- South of Paul's Park Shower
- Gate 23 at Knapp Street and Waupun Road

CAMPGROUND TRANSPORTATION

Buses circulate throughout Camp Scholler from Sat 7/20 through Sat 7/27 from 6:15 a.m. to 11 p.m., and on Sun 7/28 from 6:15 a.m.-5 p.m. Shuttles to off-site locations are available at Red One Market West (B-14) and at the Bus Park in the AirVenture grounds (G-11).



YOU'RE INVITED TO

JOIN OUR LEGACY

The established legacy of Cessna® and Beechcraft® has shaped the aviation industry for nearly a century. With a portfolio of aircraft that spans the globe, Textron Aviation inspires the journey of flight.

WHEN THE SKY IS YOUR INSPIRATION, THE POSSIBILITIES ARE ENDLESS.

Experience the newest legacy of aircraft in booth #78.

CAMPING



DUMP STATION

Dispose of all gray and black water at Stits Road. Mobile holding-tank purging services and nondrinkable water tank refills are available for a fee near Red One Market Central (G-14).

GROCERIES AND SUPPLIES

For on-site grocery, see Red One Market locations and hours in the Shopping section on Page 26.

ICE

Ice is available at all Red One Market locations listed on Page 26. For guests in aircraft camping areas, ice can also conveniently be found at Homebuilders Headquarters and the Ultralight Barn.

LAUNDRY

Facility on-site at Red One Market West (B-14)

PROPANE GAS FILL & EXCHANGE

On-site in Camp Scholler at Red One Market West (B-14)

Off-site locations:

- Fill station: One Stop Service Center, 4477 Poberezny Rd. (south of campground), 920-233-6274
- Exchange: Kwik Trip, 2400 S. Washburn St., 920-233-4080

RECYCLING

Please recycle the following items in the yellow-top receptacles:

Paper: flattened cardboard and paper cardboard (such as cereal boxes), magazines, office paper, newspapers, and brown paper bags

Plastic: bottles and containers (Nos. 1-7)

Glass: bottles and jars

Metal: aluminum, foil, tin, and steel cans

LOST AND FOUND

Main location can be found on the east side of Exhibit Hangar A/Convention HQ (J-11), at 920-230-7910, or at the Camp Scholler security office (F-15). After AirVenture week, call 920-426-6505.

FIRST AID

Camp Scholler First Aid (F-15), 920-230-7807

Fri 7/19 and Sat 7/20, 9 a.m.-4 p.m.

Sun 7/21-Sat 7/27, 8 a.m.-7 p.m.

Sun 7/28, 8 a.m.-noon

AirVenture Convention First Aid (K-10), 920-230-7808

Mon, Tue, Thu, Fri, 8 a.m.-7 p.m.

Wed and Sat 7/27, 8 a.m.-9 p.m.

Sun 7/28, 8 a.m.-3 p.m.



CAMP SCHOLLER

Accessibility

- RV/disabled-accessible camping areas for those requiring 24-hour operation of auxiliary generators are available on a first-paid, first-served basis.
- Accessible restrooms are available at three campground shower facilities.
- An accessible bus circulates throughout the campground.
- Disabled placards must be displayed on camping unit.

Campfires and Firewood

The Wisconsin Department of Natural Resources asks that all campground firewood be left at home and purchased near your campsite location.

Firewood should be obtained within 10 miles of where you plan to use it. Fines for transporting firewood across state lines are heavily enforced.

- Firewood is available for purchase at campground stores and local convenience stores.
- Do not leave campsite areas without completely extinguishing campfires.

Generators

- No generator operation from 10:30 p.m. to 6:30 a.m. (except in designated 24-hour area).
- Camping units in 24-hour generator areas must be positioned perpendicular to fire lanes.
- **No tents** are allowed in the 24-hour auxiliary power area.

Basic Campsites

- All basic campsites are on a first-paid, first-served basis. Sites may be purchased online at AirVenture.org or at the Camper Registration building. EAA members pay from their arrival date through the end of AirVenture and may not stake out a spot in advance.



JET INTO YOUR NEXT ERA

with a first-class regional airline



Visit Piedmont Airlines for more information
and meet the team at the Aviation Gateway Park:
Education & Career Center booth C24 & C25



@piedmontairlines

@piedmontairlines_

CAMPING

- On or after the arrival date, EAA members must check in at the Camper Registration building to receive their camping credentials.
- Basic sites are not marked or assigned.
- You may have one tent/camper and one vehicle on each campsite.
- Camping units must be a minimum of 10 feet apart.
- Camping credentials must be visible on both your camping unit and transient vehicle.
- Visitor parking passes (S Lot) may be purchased at the Camper Registration building.

Water and Electric Sites

- All water and electric campsites are on a first-paid, first-served basis. Sites may be purchased online at AirVenture.org or at the Camper Registration building, beginning on June 28, 2024, at 7 a.m.
- Payment for a water and electric site is calculated at the daily camping rate from the date the site is secured through the end of AirVenture. A campsite tag will be placed on the site to indicate it has been purchased.
- On or after the date the site is secured, EAA

PRESENTED BY



Beechcraft

BY TEXTRON AVIATION

members must check in at the Camper Registration building to receive their camping credentials.

- Camping credentials must be visible on both the camping unit and transient vehicle.
- Only one tent/camper and one vehicle are allowed on each campsite. Sites are approximately 25-by-50 feet.
- Additional vehicle and visitor parking passes for the overflow lot (S Lot) may be purchased at Camper Registration.

AIRCRAFT CAMPING

- By default, general camping guidelines should be followed, when applicable.
- All aircraft in the North 40 or South 40 camping areas will be charged the camping rate.
- All campsites must be paid for before setup. Always display proper camping credentials.
- Aircraft must be eligible for judging to camp in the showplane camping areas.
- All aircraft must be tied down. "Dog leash" tiedowns are prohibited.

BID TO WIN!

THURSDAY, JULY 25, 2024

USE YOUR MOBILE DEVICE
TO BID OR TO DONATE.

You don't have to attend EAA's largest annual fundraiser, **The Gathering**, to participate in the excitement of bidding on aviation-themed lots and experiences. You can participate virtually and support EAA's most vital education outreach and advocacy programs.

Visit EAA.org/BidOrDonate to view available aviation lots and experiences.

Bidding closes at 9:30 pm CST on Thursday, July 25, 2024.

believe

Scan the QR code to register to bid or donate today!



FOLLOW US



VISIT US AT
▼ **BOOTH**
▼ **226**

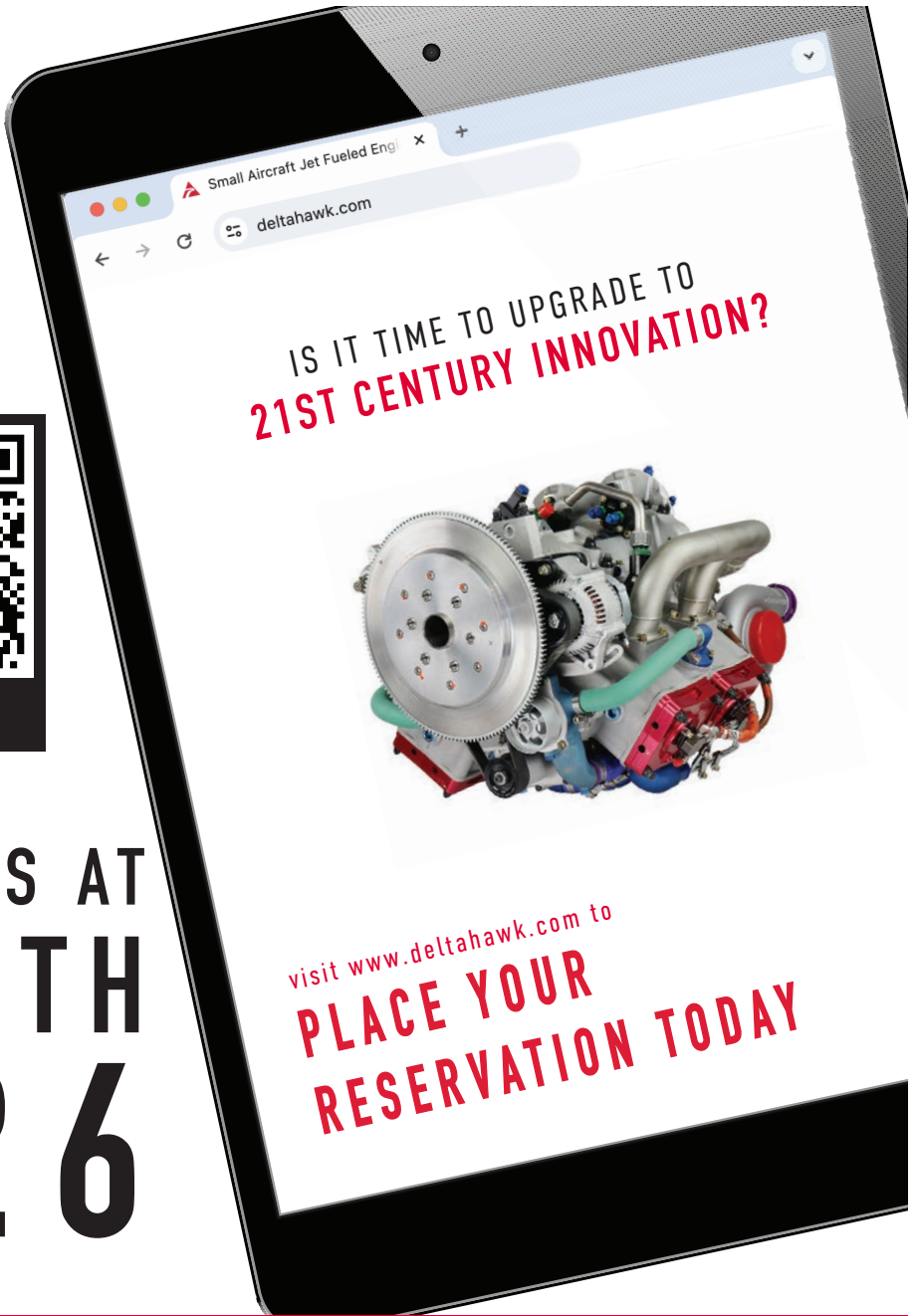

TIME TO UPGRADE



DELTAHAWK
POWER REIMAGINED®

info@deltahawk.com | Racine, WI | www.deltahawk.com

CAMPING

- Only one tent per airplane, unless a second tent is needed for immediate family members, in which case it must fit within the footprint of the aircraft.
- Generators are allowed in the North 40 camping area. Engine-driven generators may only be operated between 6:30 a.m. and 10:30 p.m.
- Aircraft engines may not be started at the campsite. On departure, aircraft must be pushed out of the campsite.
- Coolers must remain secured at your campsite location.
- Alcoholic beverage consumption is prohibited on airport property, except in officially designated areas or under specific permission given by authorized EAA staff.

Check for additional camping guidelines at the registration building or visit EAA.org/AirVenture.

Fueling operations shall be done with the utmost safety in mind, in accordance with NFPA 407.

- Prior to initiation of fueling operations, the fueling vehicle and the aircraft to be fueled shall be bonded.
- No open flame, cooking stoves, or smoking is



- permitted within 50 feet of fueling areas.
- All fuel spills shall be reported immediately to the Oshkosh Fire Department.
- All fueling hoses shall be properly stowed prior to moving the fueling vehicle.

FIRE PREVENTION

City of Oshkosh Fire Department

Cooking stoves in transient aircraft camping areas:

- Do not leave campsite areas without completely extinguishing stove.
- No charcoal or wood campfires.
- Careful use of white gas or propane camp stoves is allowed in aircraft camping, provided they are in an area away from parked aircraft and that the stove is attended at all times.
- Cooking stoves must be a safe distance (10 feet) away from any aircraft.
- In the event that the conditions at Wittman Regional Airport and on the EAA grounds change drastically before or during the convention, additional restrictions on cooking stoves may be implemented.

TAKE FLIGHT

aboard one of EAA's unique Flight Experiences

B-25 Berlin Express

\$475 per EAA member • \$495 per nonmember
B-25 Operations are located at the southeast corner of Warbird Alley

Ford Tri-Motor

\$99 per adult • \$75 per child (17 and under)
Ford Tri-Motor Operations are located at the southeast corner of Warbird Alley

Bell 47 Helicopter

\$65 per person
Helicopter Operations are located at Pioneer Airport behind the EAA Aviation Museum®





POWERLIFT[®]
Hydraulic Doors

www.powerliftdoors.com

Visit Us in
Booths #
1127, 2154,
3015, 4041

Local Manufacturing sites across the United States and Canada ensure a smooth project from start to finish on every project!



CAMPING



BY TEXTRON AVIATION

COURTESY

- Courtesy quiet time begins at 10:30 p.m.
- Please leave campsites the way you found them.
- No commercial operations are permitted in Camp Scholler.
- Noncommercial advertising, demonstrating, and soliciting must be approved in advance by EAA.
- Flying objects (i.e., RC aircraft, drones, Frisbees, etc.) are prohibited in Camp Scholler.

PERSONAL TRANSPORTATION

- **Unlicensed** motorized vehicles are prohibited.
- Roller-skating/blading, skateboarding, or use of self-balancing scooters is prohibited.
- A valid driver's license is required to operate any type of vehicle in Camp Scholler.
- Bicycles and personal transportation devices are allowed in Camp Scholler, the North 40 camping area, and the South 40 camping area.
- Single-person electric convenience vehicles and personal disability mobility devices are allowed everywhere when required because of the individual's mobility disability and when operated in a safe manner, consistent with 28 CFR 36.311(b)(1).

TRAFFIC REVERSAL

To accommodate heavy traffic during peak periods, the following traffic reversal schedule is in effect (subject to change per Sheriff's Office):

- Mon 7/22, 5-10 p.m.
- Tue 7/23, 5-10 p.m.
- Wed 7/24, 5 p.m.-12 a.m.
- Thu 7/25, 5-10 p.m.
- Fri 7/26, 5-10 p.m.
- Sat 7/27, 5 p.m.-12 a.m.



Use the Highway 26 exit from Interstate 41 and head north on Poberezny Road (frontage road) to enter the campgrounds from 5 p.m. to 10 p.m.

To get to the west side of Oshkosh from 5 p.m. to 10 p.m., use 9th Avenue (Exit 117) from I-41.

To get to the east side of Oshkosh from 5 p.m. to 10 p.m., drive south on Poberezny Road and turn left at County N/Fisk. *Note: County N/Fisk and Highway 26 are the same road.*

PET GUIDELINES

AirVenture is not a safe place for animals. If you bring your pet, please follow these guidelines:

- Pet camping is available in Camp Scholler only.
- Pets must be on a lead at all times, no longer than 8 feet.
- Clean up after your pet.
- No pets are allowed on the AirVenture convention site, including aircraft camping.
- Pets found loose will be turned over to the Winnebago County Sheriff's Office.
- Campers are subject to relocation or expulsion should staff receive complaints due to excessive pet noise or any other pet guideline violation.

REFUND PROCEDURES

Refunds are issued as you exit the campground in your vehicle.

- Vehicle pass issued with camping credentials must be surrendered to receive a refund. You will be refunded unused days, less the three-day minimum.
- No refunds are issued on Camp Scholler water and electric campsites.
- Checkout is noon daily. Campers leaving after noon will be charged for that day.

Refund Locations

Camp Scholler Camper Registration

Fri 7/19-Sat 7/27, 6 a.m.-11 p.m.

Sun 7/28, 6 a.m.-noon

South Gate (located at Stits and Ripple roads)

Wed 7/24-Sun 7/28, 6 a.m.-noon

North 40, South 40, Showplane, and Homebuilt Registration

Thu 7/18, noon-6 p.m.

Fri 7/19-Sat 7/27, 7 a.m.-6 p.m.

Sun 7/28, 7 a.m.-noon

GATE HOURS

Camper Registration Gate is open 24 hours starting Fri 6/28. West Gate (CC) and South Gate (CF) are open 9 a.m.-5:30 p.m. starting Fri 6/28. Gates that are open 24 hours starting Thu 7/18 are Gate 19, Gate 21, Gate 37, and West Gate (CC).

CAMP SCHOLLER VOLUNTEER CENTER

Open 8 a.m.-5 p.m.



UNRELIABLE FUEL QUANTITY?

YOU CAN CHANGE THIS.



Our indicators provide the gold standard of fuel level reliability with unparalleled accuracy.

Fly the skies with confidence today.

- ✓ FOR APPROVED AND EXPERIMENTAL AIRCRAFT
- ✓ COMPATIBLE WITH MOST MODERN GAUGES
- ✓ FAA AND EASA* APPROVED

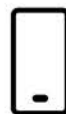

SCAN TO
LEARN MORE
CIESCORP.COM



*EASA approval through our partnership with Aerospace Logic.

DINING

HOURS

(Subject to change; not all locations open for breakfast)

Sat 7/20	10 a.m.-4 p.m.
Sun 7/21	7 a.m.-7 p.m.
Mon 7/22 and Tue 7/23	7 a.m.-9 p.m.
Thu 7/25 and Fri 7/26	7 a.m.-9 p.m.
Wed 7/24 and Sat 7/27	7 a.m.-10 p.m.
Sun 7/28	7 a.m.-12 p.m.

EAA MEMBER MEAL

Present your EAA member card at participating locations to receive a special or discounted meal. Meals and prices vary by location.

HEALTHY ALTERNATIVES

Looking for healthy alternatives or to fulfill a dietary restriction? Plan ahead by previewing the location menus at AirVenture. While you are on the grounds, you can find gluten-free or vegetarian options indicated on menus with the icons below.

 GLUTEN FREE

 VEGETARIAN

 VEGAN











 DAIRY FREE

 EAA MEMBER DEAL

ALL THINGS JERKY

- Showplane Concessions by All Things Jerky (L-16)

A&W

- Classic Concessions by A&W and Freedom Foods (L-12)   
- Exhibit Hangar B by A&W (J-13)  
- Fly Market Concessions by A&W (H-13)   
- Tower Concession by A&W (J-11)   

BEN'S SOFT PRETZELS

- Showplane Concessions by Ben's Soft Pretzels (L-16)

BENVENUTO'S

- Flyboy Concessions by Benvenuto's (K-6) 
- Fightertown Café by Benvenuto's (K-6)  
- Twin Oaks Food Court by Benvenuto's (J-12)  

CHICK-FIL-A

- HQ Concessions by Chick-fil-A (J-11)

THE DOUGH SHOPPE

- Twin Oaks Food Court by The Dough Shoppe (J-12)

DUNKIN'/BASKIN-ROBBINS

- Showplane Concessions by Dunkin'/Baskin-Robbins (L-16)
- Twin Oaks Food Court by Dunkin'/Baskin-Robbins (J-12)
- Homebuilt Concessions by Dunkin'/Baskin-Robbins (L-8)

EL AGAVE MEXICAN GRILL & CANTINA

- Exhibit Hangar B Food Truck by El Agave Mexican Grill & Cantina (J-14)
- Brown Arch Concessions Food Truck by El Agave Mexican Grill & Cantina (L-10)

FARIS GOURMET POPCORN

- Ultralight Concessions by Faris Gourmet Popcorn (L-20)

FATHER CARR'S

- South 40 by Father Carr's (J-33)

FREEDOM FOODS

- EAA Aviation Center Concessions by Freedom Foods (B-8)   
- Classic Concessions by A&W and Freedom Foods (L-12)  
- KidVenture by Freedom Foods (D-7)   
- North 40 Café by Freedom Foods (G-4)  

FREEDOM TO EXPLORE™



VISIT US AT THE SEAPLANE BASE & ON CELEBRATION WAY



info@wipaire.com | 651.451.1205
South St. Paul, MN (KSGS)



HEART OF AMERICA RESTAURANTS

- Homebuilt Café by Heart of America Restaurants (L-8)   

JERSEY MIKE'S SUBS

- Homebuilt Concessions by Jersey Mike's Subs (L-8)  

LEMON CHILL

- Located throughout the EAA AirVenture grounds
- Bavarian Pretzel Stand by Lemon Chill (L-13)   

THE MACHINE SHED

- Hangar Café by The Machine Shed (L-15) 
- Hangar Concessions by The Machine Shed (L-15)

MAJOR GOOLSBY'S

- Waypoint Café by Major Goolsby's (K-11) 
- Vintage Café by Major Goolsby's (L-15) 









MILE HIGH PUB

- Seaplane Base Concessions by Mile High Pub 

MR. AND MRS. EGGROLL

- Exhibit Hangar B Food Truck by Mr. and Mrs. Eggroll (J-14)







OSORIO'S LATIN FUSION

- Twin Oaks Food Court by Osorio's Latin Fusion (J-12)   
- Ultralight Concessions Food Truck by Osorio's Latin Fusion (L-20)   
- Forums Food Truck by Osorio's Latin Fusion (K-8)   

PAPA JOHNS

- Exhibit Hangar A by Papa Johns (I-12) 
- Fly-In Theater by Papa Johns (E-14) 
- Twin Oaks Food Court by Papa Johns (J-12) 
- Ultralight Concessions by Papa Johns (L-20) 

PARKER JOHN'S BBQ

- Ultralight Café by Parker John's BBQ (L-15)   
- Tailwinds Café by Parker John's BBQ (K-9)   

PETE'S GARAGE BAR

- Hangar D Concessions by Pete's Garage Bar (H-14)

RICHIE'S CHEESE CURD TACOS

- South 40 by Richie's Cheese Curd Tacos (M-24)
- College Park Concessions by Richie's Cheese Curd Tacos (J-10)

STONE ARCH BREWPUB

- The Outer Marker by Stone Arch Brewpub (I-11)

SUBWAY

- Vintage Concessions by Subway (K-14) 

TALL PINES CAFÉ

- Tall Pines Café by Vintage Aircraft Association (L-20)
Serving breakfast Sat 7/20-Sat 7/27,
6:30-11a.m.

THUNDER BAY

- Celebration Way by Thunder Bay (I-13)   

TRAVELIN' TOM'S COFFEE

- Fly-In Theater by Travelin' Tom's Coffee (E-14)

RED ONE MARKET

- (B-14, C-19, D-21, G-14, H-4, J-33, K-28)

 GLUTEN FREE

 VEGETARIAN

 VEGAN

 DAIRY FREE

 EAA MEMBER DEAL



The Insurance Protection Student Pilots Need

Take flight with Starr Gate, the iPad app from Starr Insurance Companies, a global leader in aviation insurance. Starr Gate helps you fly safer, and makes buying and saving on flexible, month-to-month coverage easier than ever.



Buy Coverage by the Month

Choose insurance that fits the way you fly and get quotes in minutes. Purchase coverage by the month or the year through the Starr Gate app.



Insure Your Solo Flight

With the right coverage, you'll have the peace of mind to focus on your training. We cover single engine, multi engine, rotorcraft, and single-engine seaplanes.



Make the Skies Safer

With flight scoring powered by CloudAhoy, you can improve your performance and share your score with fellow students to set an example for safety.

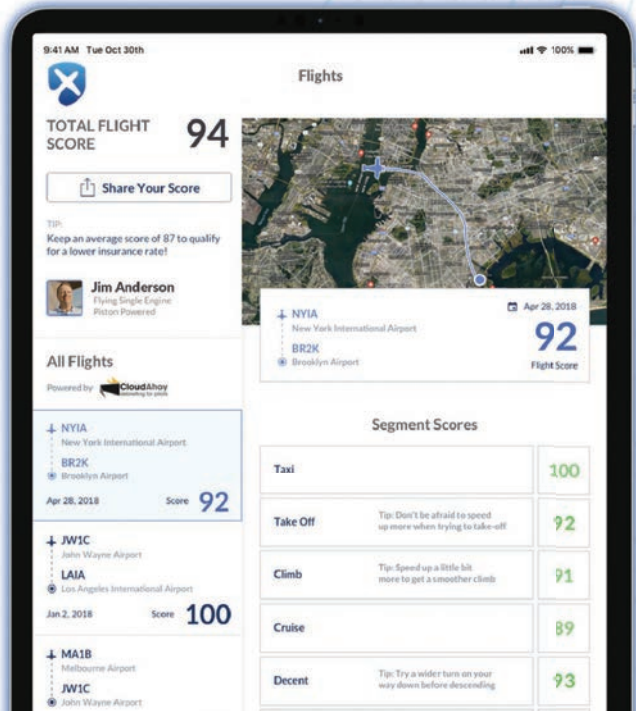

Learn more at STARRGATE.COM



Powered by  **CloudAhoy**
debriefing for pilots

SHOPPING

EAA MERCHANDISE

Visit these locations to get your official AirVenture merchandise, including event T-shirts, polo shirts, button-down shirts, sweatshirts, hats, toys, model airplanes, books, souvenirs, gifts, and much more.

Look for the orange windsocks on the EAA merchandise tents.

Barnstormer Boutique – EAA Aviation Museum (B-8)

Sat 7/20, 8 a.m.-5 p.m.; Sun 7/21, Mon, Tue, Wed, Fri, and Sat 7/27, 8 a.m.-6 p.m.; Thu, 8 a.m.-3 p.m. (Museum closes at 3 p.m.); Sun 7/28, 8 a.m.-5 p.m.

Fly Market - EAA Merchandise (H-14)

Mon 7/22-Sat 7/27, 8 a.m.-6 p.m.;
Sun 7/28, 8 a.m.-4 p.m.

EAA Wearhouse (J-12)

Sat 7/20 and Sun 7/21, 8 a.m.-5 p.m.;
Mon, Tue, and Thu, Fri, 8 a.m.-8 p.m.;
Wed and Sat 7/27, 8 a.m.-9 p.m.;
Sun 7/28, 8 a.m.-5 p.m.

EAA Four Corners (J-13)

Mon, Tue, Thu, Fri, 8 a.m.-8 p.m.;
Wed and Sat 7/27, 8 a.m.-9 p.m.;
Sun 7/28, 8 a.m.-5 p.m.

Homebuilders Headquarters Store (L-9)

Sat 7/20-Fri 7/26, 8 a.m.-5 p.m.;
Sat 7/27, 8 a.m.-2 p.m.

KidVenture (D-7)

Mon 7/22-Sun 7/28, 8 a.m.-5 p.m.

Main Gate (G-13)

Mon 7/22-Sat 7/27, 8 a.m.-7 p.m.;
Sun 7/28, 8 a.m.-4 p.m.

Showcase (L-13)

Sat 7/20 and Sun 7/21, 8 a.m.-5 p.m.;
Mon, Tue, Thu, Fri, 8 a.m.-8 p.m.;
Wed and Sat 7/27, 8 a.m.-9 p.m.;
Sun 7/28, 8 a.m.-5 p.m.

Ultralight Barn (K-18)

Sun 7/21, 8 a.m.-6 p.m.;
Mon 7/22-Sat 7/27, 7 a.m.-6 p.m.;
Sun 7/28, 7 a.m.-1 p.m.

OTHER MERCHANDISE

Aeromart (H-14)

Mon 7/22-Fri 7/26, 9 a.m.-5 p.m.;
Sat 7/27, 9 a.m.-noon

Call it a swap meet or consignment sale; the Aeromart is one of the best places to buy new and used aircraft parts and other aviation items.

Fly Market (H-14)

Mon 7/22-Sat 7/27, 9 a.m.-5 p.m.;
Sun 7/28, 9 a.m.-4 p.m.

You'll find a vast array of exhibitors selling aviation and nonaviation products, from hangar doors to die-cast aircraft models, at this fun outdoor market.

International Aerobatic Club (IAC) Aerobatic Center and Vicki Cruse Educational Pavilion (L-12)

Sun 7/21, 8 a.m.-5 p.m.; Mon-Thu, 8 a.m.-6 p.m.;
Fri, 8 a.m.-4:30 p.m.; Sat 7/27, 8 a.m.-5 p.m.;
Sun 7/28, 8 a.m.-noon

Vintage Red Barn Gift Store (L-14)

Sat 7/20-Sun 7/21, 1-4 p.m.;
Mon, Tue, Thu, Fri, 9 a.m.-5:30 p.m.;
Wed and Sat 7/27, 11 a.m.-7 p.m.;
Sun 7/28, 11 a.m.-4 p.m.

Warbirds Gift Store (L-6)

Fri 7/19-Sat 7/20, 1-5 p.m.;
Sun 7/21-Fri 7/26, 9 a.m.-6 p.m.;
Sat 7/27-Sun 7/28, 9 a.m.-3 p.m.



When it comes to GA there's unmatched strength in the

POWER OF ONE.

For more than 50 years, Covington has remained true to the power of one. We are one family. Servicing engines from one manufacturer. With one guiding commitment: To build our company one relationship, and one engine, at a time. And, as the one and only family-owned Pratt & Whitney Canada factory-designated overhaul facility, no one knows the PT6A better, nor delivers more uncompromising support. All with a level of trust and compassion you simply won't find anywhere else. Call or visit us today. It would be our privilege to put the power of one to work for you.



SHOPPING

GROCERY

Scholler - Red One Market Central (G-14)

Mon 7/15, 11 a.m.-7 p.m.;
Tue 7/16-Thu 7/18, 7 a.m.-9 p.m.;
Fri 7/19-Sat 7/27, 5:30 a.m.-9:30 p.m.;
Sun 7/28, 5:30 a.m.-5 p.m.; Mon 7/29, 7 a.m.-12 p.m.

Scholler - Red One Market South (D-21)

Fri 7/19-Sat 7/27, 5:30 a.m.-9 p.m.;
Sun 7/28, 5:30-9 a.m.

Scholler - Red One Market Southwest (C-19)

Wed 7/17 and Thu 7/18, 7 a.m.-9 p.m.;
Fri 7/19-Sat 7/27, 5:30 a.m.-9:30 p.m.;
Sun 7/28, 5:30-9 a.m.

Scholler - Red One Market West (B-14)

Wed 7/17 and Thu 7/18, 7 a.m.-9 p.m.;
Fri 7/19-Sat 7/27, 5:30 a.m.-9:30 p.m.;
Sun 7/28, 5:30-9 a.m.



Wittman - Red One Market North 40 (H-4)

Wed 7/17, 11 a.m.-7 p.m.; Thu 7/18, 7 a.m.-9 p.m.;
Fri 7/19 -Sat 7/27, 6 a.m.-9 p.m.; Sun 7/30, 6-9 a.m.

Wittman - Red One Market Showplane (L-24)

Fri 7/19-Sat 7/27, 6 a.m.-9 p.m.;
Sun 7/28, 6-9 a.m.

Wittman - Red One Market South 40 (J-33)

Fri 7/19-Sat 7/27, 6 a.m.-9 p.m.;
Sun 7/28, 6-9 a.m.

*Bring home
your favorite*
**EAA® AirVenture®
Oshkosh™ 2024
souvenirs!**

Available at all EAA
merchandise locations.



SHOP NOW AT [SHOPEAA.ORG](https://shop.eaa.org)

Call 800-564-6322 | All purchases support EAA® programs and promote The Spirit of Aviation®.



WHERE DREAMERS SOAR.

We're dreamers - and so are our customers. From rewarding careers to rewarding our SkyMiles® members, Delta takes you higher through career opportunities, unforgettable brand experiences and a history that is truly unique.

Visit the Delta Pavilion (#501) to learn more about the Delta Difference.

Not a SkyMiles member?
Scan the QR code to join now.



Delta Difference Experience Highlights

- Tour one of our Airbus aircraft when it arrives on Tuesday, July 23rd.*
- Each day the first 100 SkyMiles members who visit the Delta Pavilion will receive an exclusive giveaway.
- Learn more about Delta's people-first culture and how we earned a spot on Fortune's 100 Best Companies to Work For® list for the fifth year.
- Stock up on fun Delta branded swag from our pop-up Delta Shop.
- Explore our 99 year history from interactive videos.
- SkyMiles members get exclusive access to the Sky Club Lounge observation deck to enjoy the airshows**.

* Visit the static display on Tuesday, July 23rd in Boeing Plaza to tour the aircraft. Tour hours will be announced that day.

** Access is on a first-come basis and is based on capacity limits. The deck will be open for all afternoon shows and the Wednesday night airshow only.

KEEP CLIMBING



NEIGHBORHOODS

Check the presentation schedule for daily activities in each neighborhood.

EAA SEAPLANE BASE

Presented by Wipaire

Mon 7/22-Sat 7/27, 8 a.m.-6 p.m.;
Sun 7/28, 8 a.m.-noon



Six miles southeast of Wittman Regional Airport. Parking is limited. Take a shuttle bus (\$3 round trip) from the Bus Park (G-11) or the bus stop at the south end of the flightline (past the Ultralights area).

Bus hours: Sat 7/20, noon-5 p.m.; Sun 7/21-Fri 7/26, 8 a.m.-8 p.m.; Sat 7/27, 8 a.m.-9 p.m.; and Sun 7/28, 8 a.m.-noon. AirVenture wristbands required.

HOMEBUILDERS HEADQUARTERS (L-9)



Thu 7/18, noon-5 p.m.;
Fri 7/19-Wed 7/24, 7 a.m.-8 p.m.;
Thu 7/25-Sat 7/27, 7 a.m.-5 p.m.; Sun 7/28, 7 a.m.-noon

- Homebuilders Hangar, supported by Aircraft Spruce & Specialty: Mon 7/22-Sat 7/27, 8:30 a.m.-5 p.m.; Sun 7/28, 8:30 a.m.-1 p.m.
- Forums and Aircraft Spruce & Specialty Workshops Plaza: Mon 7/22-Sat 7/27, 8:30 a.m.-4 p.m.; Sun 7/28, 8:30 a.m.-1 p.m.
- Aeroplane Workshop:
Mon 7/22-Sat 7/27, 8:30 a.m.-4 p.m.;
Sun 7/28, 8:30-10:30 a.m. (workshops only)

INTERNATIONAL AEROBATIC CLUB (IAC) AEROBATIC CENTER AND VICKI CRUSE EDUCATIONAL PAVILION (L-12)



Sun 7/21, 8 a.m.-5 p.m.;
Mon 7/22-Thu 7/25, 8 a.m.-6 p.m.;
Fri 7/26, 8 a.m.-4:30 p.m.; Sat 7/27, 8 a.m.-5 p.m.;
Sun 7/28, 8 a.m.-noon
Forums: Tue 7/23-Fri 7/26, 8:30 a.m.-2:15 p.m.

KIDVENTURE (D-7)

Mon 7/22-Sat 7/27,
9 a.m.-3:30 p.m.
Sun 7/28, 9 a.m.-2 p.m.



ULTRALIGHTS, LIGHTPLANES, HOMEBUILT ROTORCRAFT (K-18)



Sun 7/21, 8 a.m.-6 p.m.;
Mon 7/22-Sat 7/27, 7 a.m.-6 p.m.;
Sun 7/28, 7 a.m.-1 p.m.

- Powered parachutes: 7-9 a.m. and 7:30-8 p.m.
- Ultralights and lightplanes: 9-11:30 a.m. and 6:30-7:30 p.m.
- Rotorcraft: 11:30 a.m.-2:30 p.m.
- Twilight Flight Fest: Mon, Tue, Thu, Fri, 8-9:30 p.m.
- Hot air balloon launch: Sat 7/27, 6 a.m.

VINTAGE (L-14)



Fri 7/19, 9 a.m.-5 p.m.;
Sat 7/20, 8 a.m.-5 p.m.;
Sun 7/21-Sat 7/27, 8 a.m.-6 p.m.; Sun 7/28, 8 a.m.-4 p.m.
(Limited operations)
Forums and Workshops: Mon 7/22-Fri 7/26, 8 a.m.-noon

WARBIRDS

Warbirds Headquarters (L-6)

Thu 7/18-Sat 7/27, 8 a.m.-5 p.m.
(Subject to change)



Warbirds Tram Tours

Mon 7/22-Sat 7/27, 8 a.m.-2 p.m.
Tickets are free, but preregistration is recommended.

Warbirds Gift Store

Fri 7/19-Sat 7/20, 1-5 p.m.
Sun 7/21-Fri. 7/26, 9 a.m.-6 p.m.
Sat 7/27-Sun 7/28, 9 a.m.-3 p.m.

Vlado Lenoč Youth Education Center, featuring Redbird Flight Simulators

Mon 7/22-Sat 7/27, 9 a.m.-3 p.m.

MAKE THE PERFECT LANDING

Your Embry-Riddle degree helps set a course for success

Enrolling in an aviation-related degree program at Embry-Riddle Aeronautical University puts you at the forefront of an industry that offers exceptional career opportunities.

In addition to the academic foundation provided by expert instructors, you'll get vital hands-on experience in glass instrument panel aircraft, labs that replicate real-world airspace, state-of-the-art maintenance facilities and unrivaled aviation simulators.

With campuses in Florida and Arizona and a range of online offerings, Embry-Riddle opens new doors to aviation opportunities around the globe.

embryriddle.edu/oshkosh



Learn more!

EMBRY-RIDDLE
Aeronautical University

HORIZON[®]

H O B B Y

WE ARE
RADIO
CONTROL



E-flite Cirrus SR22T



E-flite RJ Gritter Decathlon

Our booth features RC Crawler Try Me activities, RealFlight RC flight simulators, show specials, and more! See you there!

ARRMA Gorgon
4X2 Mega 550





E-flite Viper Jet

Be sure to come by to register to win a \$500 shopping spree!

**COME
SEE
US**

Booth 505
Between
Hangar A and C
Look for the
Horizon Hobby Tent!

Scan code for more information on our products or visit horizonhobby.com

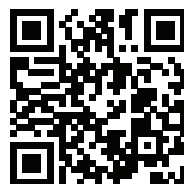

Axial SCX10
Jeep CJ-7



Losi 1/4
Promoto-MX
Motorcycle

EXHIBITORS

EXHIBITOR HOURS

Mon 7/22-Sat 7/27: 9 a.m.-5 p.m.

Sun 7/28: 9 a.m.-4 p.m.

Ultralights exhibit area closes at 3 p.m.

FINDING EXHIBITORS

An easy way to find an exhibitor is by checking the alphabetical list inside this section of the *Official Visitor's Guide*. Simply look up the exhibitor's name and booth number. Then check the Booth Key to locate the building and the corresponding map for the exact location.

If you prefer an electronic version, download the official EAA AirVenture Oshkosh 2024 app, sponsored by Honeywell, to your Apple or Android smartphone or tablet.

EXHIBITOR BOOTH KEY	BOOTH	EXHIBIT AREA	MAP PAGE
	1-505	Main Aircraft Display	58-59
	600-650	Homebuilt Aircraft Display	60
	700-832	Fly Market, Aeromart	60
	900-953	Ultralight/Rotorcraft Display	61
	1001-1160	Aircraft Spruce & Specialty Exhibit Hangar A	62
	2001-2161	Co-Pilot Goose Exhibit Hangar B	64
	3000-3176	Epic Aircraft Exhibit Hangar C	66
	4001-4114	DeltaHawk Engines Exhibit Hangar D	68
	E1-E30	EAA Education and Career Center presented by Piedmont Airlines	58
	IFP1-IFP22	International Federal Pavilion (Inside Exhibit Hangar D)	68
	C1-C26	EAA Career Center presented by Air Wisconsin Airlines	58
	SPB	EAA Seaplane Base presented by Wipaire	
	39-72 A & B	Aviation Gateway Park presented by Piper Aircraft, Inc.	58
	WV1-WV14	EAA WomenVenture Center	58

RED COMPANY NAMES Celebrating an AirVenture participation milestone anniversary
BLUE COMPANY NAMES New to AirVenture as an exhibitor
GREEN BOOTH #S Participating in the Aviation Job Fair supported by JSfirm.com

COMPANY	BOOTH #	COMPANY	BOOTH #
1st Pick Antiques & Vintage LLC	707	AED METALS	2094
360 Avionics	1082	Aegis Auto Acc	1084
4 Paws Aviation	1010	Aero Hose Shop	3061; 3062
A		Aero Mach Wilco, LLC	1089-1091
A Spice Above	768	Aerocet Inc.	255; 256
A-10 Aviation Products	766	AeroConversions, LLC	603
Abingdon Co.	3149; 3150	AeroCreeper	2086
AC Air Technology	313	AeroLEDs	3032
Academy of Aviation	40	Aeromarine LSA	195
Accelerated Aviation Instruction LLC	E12	AeroShell	446; 457
Aces High Gallery	3026	Aerospace Welding Minneapolis, Inc.	2057
ACES Systems	1154	Aerotranscendent Inc.	443
ACME Suspensions LLC	458	Aertronics, Inc.	1074; 1075
ACR Electronics, Inc.	3122	Aeroverse Media, LLC	220
Acrisure Aerospace Insurance Solutions	262	Aerox Aviation Oxygen Systems	1133
Adept Propulsion Technologies, Inc.	90	AEVEX Aerospace	340
Advanced Flight Systems, Inc.	496A; 4034A; 4035AA; 4035AB	Affection Above Aviation	316
Advanced Marketing Int'l, Inc.	820	African Elephant Hair Bracelets by Safari Jewelry - 20 Year Anniversary	3128
Advanced Powerplant Solutions (APS)	1118	AFWERX	439
Adventist World Aviation	4085	Aileronics Inc	2119
Advocate Consulting Legal Group, PLLC - 20 Year Anniversary	3165	Aims Community College	51
		Air Cargo Carriers	C17

Build It. Fly It!

With Zenith Aircraft

Since 1992



The incredible "Sky Jeep"

STOL CH 750 Super Duty

True Short Take-Off & Landing Performance and Capability



Amazing STOL performance!



Rear jump seat!



More power, useful load, and performance!



Zenith CH 750: STOL and Cruiser

Easy cabin access with large doors, huge cabin, comfortable seating, great visibility
Outstanding performance with standard tricycle gear with steerable nosewheel.



Sleek low-wing Zenith CH 650



Complete Kits, Ready for Assembly
* Based on actual FAA registrations

Zenith Aircraft kits represent outstanding value, with direct support from the factory. Manufactured using state-of-the-art CNC technology, complete kits are now easier and quicker to build than ever. Complete your personalized Zenith with your choice of engine and avionics. **BUILD IT and FLY IT with Zenith Aircraft Company!**

33rd Annual
Zenith Homecoming
Open Hangar Days & Fly-In
September 20 & 21 at the factory in Missouri

zenithair.net



Zenith Aircraft Company
1881 Airport Road, Mexico, Missouri 65265

EXHIBITORS

EXHIBITOR BOOTH KEY	BOOTH	EXHIBIT AREA	MAP PAGE
	1-505	Main Aircraft Display	58-59
	600-650	Homebuilt Aircraft Display	60
	700-832	Fly Market, Aeromart	60
	900-953	Ultralight/Rotorcraft Display	61
	1001-1160	Aircraft Spruce & Specialty Exhibit Hangar A	62
	2001-2161	Co-Pilot Goose Exhibit Hangar B	64
	3000-3176	Epic Aircraft Exhibit Hangar C	66
	4001-4114	DeltaHawk Engines Exhibit Hangar D	68
	E1-E30	EAA Education and Career Center presented by Piedmont Airlines	58
	IFP1-IFP22	International Federal Pavilion (Inside Exhibit Hangar D)	68
	C1-C26	EAA Career Center presented by Air Wisconsin Airlines	58
	SPB	EAA Seaplane Base presented by Wipaire	
	39-72 A & B	Aviation Gateway Park presented by Piper Aircraft, Inc.	58
WV1-WV14	EAA WomenVenture Center	58	

RED COMPANY NAMES Celebrating an AirVenture participation milestone anniversary
BLUE COMPANY NAMES New to AirVenture as an exhibitor
GREEN BOOTH #S Participating in the Aviation Job Fair supported by JSfirm.com

COMPANY	BOOTH #	COMPANY	BOOTH #
Air Command Gyroplanes / Skywheels Rotors	939	Airtex Products, Inc	1066; 1067
Air Force Materiel Command	477; AF1; AF2	Airtex	3008
Air Force Research Laboratory (AFRL)	IFP-12	Airwolf Filter Corp.	287
Air Journey	3120	Aithre, Inc.	1064; 1065
Air Line Pilots Association, Int'l	329; 338	Alion Aviation s.r.o.	269
Air Methods LLC	C4	All American Gutter Protection	2123
Air Mod	2056	Alpha Aviation Inc	3112
Air Race Classic, Inc - 10 Year Anniversary	2122; WV13	Alpha Systems AOA	3124; 3125
Air Safaris International Inc.	3106	ALSIM	2018
Air Wisconsin Airlines LLC	C1; C2	American Additive Manufacturing LLC	3018
Airbily Inc.	741	American Aircraft Company LLC	425; 945A
Airbus Americas, Inc.	450	American Airlines, Inc.	C23
AirCam / Lockwood Aircraft Corp.	907-909	American Bonanza Society	334; 335; 336
Aircraft Automation	3076	American Champion Aircraft Corp.	223-225
Aircraft Components INC.	1068	American Legend Aircraft Company - 20 Year Anniversary	379; 386
Aircraft Electronics Association - 30 Year Anniversary	2035; 2036	Anthros	4102
Aircraft Owners and Pilots Association	463	Appareo	3174-3176
Aircraft Performance Group Avionics LLC	3072D	Approach Fast Stack	1079; 1080
Aircraft Specialties Lubricants	3097; 3098	APS Brakes	3060
Aircraft Specialties Services, Inc.	257	Arcus Aero	177; 178
Aircraft Specialty Flightlines	947-949	Arion Aircraft, LLC	641; 642
Aircraft Spruce & Specialty Co.	476; 1022	Arisma Group LLC DBA Upflyte Technologies	1076
Aircraft Tool Supply - 40 Year Anniversary	4030-4033	Art-Craft Optical	743
Airfasco, Inc	93; 94	Art-Craft Paint Inc.	4099
AirFleet Capital, Inc.	1144	ASA	71; 2075-2078
Airforms, LLC	3132A	Asian Women in Aerospace and Aviation Inc.	WV10
AirGizmos, LLC	2084; 2085	Aspen Avionics	2145-2148
Airhart	319	AssuredPartners Aerospace	459
AirMart, Inc.	326	Astronics/PECO Inc Max-Viz	4050
Airmaster Propellers Ltd	1059	ATI Forged Products	785
Airmate	2004	Atlanta Air Recovery and Exchange	705; 706
Airparts Inc	700	ATP Flight School	117
AirSpace Auctions	4088	Auburn University Aviation	E28
AirSync Inc.	4108	AutoGyro USA Inc.	271; 945
Air-Tech Coatings LLC	360	AV8 Realty	723; 724
Air-Tech Inc.	936	AV8R GEAR	734

Bryan Turner, creator of *Just Plane Silly*,
in his *Lightspeed Delta Zulu™*

FLY *your* WAY

Go ahead, be picky.

Fine-tuning performance is how a good pilot becomes a great pilot. That's why we don't just offer *one* best-in-class ANR headset – we offer a whole fleet of them. Find the Lightspeed that's right for you.



Lightspeed
Delta Zulu™



Lightspeed
Zulu 3



Lightspeed
Sierra®



lightspeedaviation.com

FIND YOUR BEST FIT!

Come Visit us at Lot 259
Outside Hangar B

EXHIBITORS

EXHIBITOR BOOTH KEY	BOOTH	EXHIBIT AREA	MAP PAGE
	1-505	Main Aircraft Display	58-59
	600-650	Homebuilt Aircraft Display	60
	700-832	Fly Market, Aeromart	60
	900-953	Ultralight/Rotorcraft Display	61
	1001-1160	Aircraft Spruce & Specialty Exhibit Hangar A	62
	2001-2161	Co-Pilot Goose Exhibit Hangar B	64
	3000-3176	Epic Aircraft Exhibit Hangar C	66
	4001-4114	DeltaHawk Engines Exhibit Hangar D	68
	E1-E30	EAA Education and Career Center presented by Piedmont Airlines	58
	IFP1-IFP22	International Federal Pavilion (Inside Exhibit Hangar D)	68
	C1-C26	EAA Career Center presented by Air Wisconsin Airlines	58
	SPB	EAA Seaplane Base presented by Wipaire	
	39-72 A & B	Aviation Gateway Park presented by Piper Aircraft, Inc.	58
WV1-WV14	EAA WomenVenture Center	58	

RED COMPANY NAMES Celebrating an AirVenture participation milestone anniversary
BLUE COMPANY NAMES New to AirVenture as an exhibitor
GREEN BOOTH #S Participating in the Aviation Job Fair supported by JSfirm.com

COMPANY	BOOTH #	COMPANY	BOOTH #
Avemco Insurance Company	1158-1160	BANK	3132
Aveo Engineering	4040	Barking Pixel	3100
Aviat Aircraft Inc - 30 Year Anniversary	205	Barrett Precision Engines, Inc.	3072A
Aviation Depot	4075; 4100	BAS Part Sales	207
Aviation Fabricators	1139	Bat Hawk Aircraft, Inc.	903
Aviation Insurance Resources an Acrisure Partner	1120	Bath Fitter	804
Aviation International UK	1008	Batteries America	1146
Aviation Jewelry.com - 50 Year Anniversary	2116; 2117	Battery Saver	3058A
Aviation Laboratories, Inc.	3121D	Bearhawk Aircraft	608; 609
Aviation Real Estate Digital Magazine - Aviation Real Estate Specialists	819	Bede Aero LLC	626; 627
		Bell Textron Inc.	78
Aviation Search Group LLC	C26	Beringer Aero USA	437
Aviation Soul	4046; 4072	Bessie Coleman Foundation	WV1
Aviation Women Inspiring Next Generation, LLC (A-WING)	WV12	Best Aviation Products	3130B
Aviatize	424	Better Aircraft Fabric, Inc	300
Aviator Assistant Inc.	2072; 2073	Big Skinny Wallets / Burano Collection / Design 9000	3107
Aviator Cookie Company	763	Big South Fork Airpark	3086
AviatorProducts.com	3109	Big-Screw Aircraft Tie-Down	2088
Avidyne Corporation	3130A	Black Max Brakes	938
Avilution, LLC	417; 418	Blackbird Flight Wear Inc.	761; 781
AviNation	788	Blackhawk Aerospace	322
Avionics Place Inc.	4061	Blackhawk Paramotor USA Inc.	915
Avionics Systems LLC	3077	Blackstone Laboratories, Inc.	2063
AvWxWorkshops Inc	4003	BLR Aerospace LLC	2016; 2017
AXIL & Associated Brands, LLC	1138	Blue Collar Aviation	915A
B		Bluff City Aircraft	930
B & C Specialty Products Inc.	1155; 1156	Boeing Company (The) - 30 Year Anniversary	747; C18 ; 747C
B&B Aircraft Supplies	704	Bolder Flight Systems Inc.	444
B.A.S., Inc.	3147	Bose Corporation	283-285
Bad Dog Tools	813	Brainomat LLC	4004
Badland Aircraft	913	BRC Aircraft	194
Badlands Stol Aircraft, LLC	917	Breitling USA	3039
Bahamas Government	IFP-11	Brewer Brothers	744
BALL WATCH SA	4106	Bristell Aircraft LLC - 10 Year Anniversary	449; 950; 951
Ballistic Recovery Systems, Inc. - 10 Year Anniversary	166; 167	Britts Leather Sales	762
		Brown & Miller Racing Solutions	715

RUNWAY 18R

WITTMAN RD

BOEING PLAZA

KNAPP ST

 Hangar B/Aisle D



Games and prizes!
11:00 a.m. daily
Aviation Gateway Park



WAWKAU AVE
JAMES RAY BLVD
CELEBRATION WAY

MULVA WAY

VISIT ASA

HANGAR B, AISLE D

Browse and purchase the full ASA product line.



— Since 1940 —

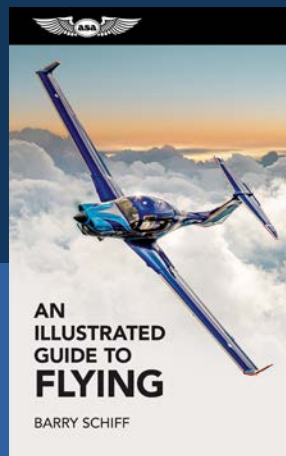

Pick up your copy of *An Illustrated Guide to Flying* at both locations.

EXHIBITORS

EXHIBITOR BOOTH KEY	BOOTH	EXHIBIT AREA	MAP PAGE
	1-505	Main Aircraft Display	58-59
	600-650	Homebuilt Aircraft Display	60
	700-832	Fly Market, Aeromart	60
	900-953	Ultralight/Rotorcraft Display	61
	1001-1160	Aircraft Spruce & Specialty Exhibit Hangar A	62
	2001-2161	Co-Pilot Goose Exhibit Hangar B	64
	3000-3176	Epic Aircraft Exhibit Hangar C	66
	4001-4114	DeltaHawk Engines Exhibit Hangar D	68
	E1-E30	EAA Education and Career Center presented by Piedmont Airlines	58
	IFP1-IFP22	International Federal Pavilion (Inside Exhibit Hangar D)	68
	C1-C26	EAA Career Center presented by Air Wisconsin Airlines	58
	SPB	EAA Seaplane Base presented by Wipaire	
	39-72 A & B	Aviation Gateway Park presented by Piper Aircraft, Inc.	58
WV1-WV14	EAA WomenVenture Center	58	

RED COMPANY NAMES Celebrating an AirVenture participation milestone anniversary
BLUE COMPANY NAMES New to AirVenture as an exhibitor
GREEN BOOTH #S Participating in the Aviation Job Fair supported by JSfirm.com

COMPANY	BOOTH #	COMPANY	BOOTH #
Bruce's Custom Covers	3121A; 3121C	Cleveland Tool	617
Buiqui Aerospace and Eagle Aircraft Flight Academy	174; 175	Cleveland Wheels & Brakes by KAMAN	3087; 3088
BULBAG, LLC	1009	Click Bond, Inc.	3035; 3036
Burnell Enterprises LLC. - Ultimate Hose Nozzle	711	CO Guardian LLC	3071
Butler Parachute Systems, Inc.	3085	Collins Aerospace	2058-2060
BWI Aviation Insurance Agency, Inc.	3019; 3020	Colorado Division of Aeronautics / Colorado Pilots Association	3047
C		Colorado Northwestern Community College	E20
California Aeronautical University	69; 70	Comp Air Enterprises	217
California Baptist University	3009	Composite FX	940-942
Callsign Aviation	778	Concorde Battery Corporation - 40 Year Anniversary	2053; 2054
Can Key (The)	2037	Continental Aerospace Technologies, Inc.	229
Canadian Owners and Pilots Association (COPA)	400D	Controller	3151; 3152
Cape Woolamai Mercantile Co	817	Cool Heli	754
Capitol Technology University	E4	Co-Pilot Goose AeroSys Technologies Inc.	2162; 258A
Caribbean Flying Adventures	3146	Countryview Powered Parachutes	914
Cascade Aircraft Conversions	288	Covington Aircraft Engines, Inc.	261; 287; 288
Category Sports	4109	Craig Mantegna	720
CAV Systems - 30 Year Anniversary	88; 89	Crewchief Systems	1053; 1054
Central Washington University	E26	Crow Safety Gears	3065
Cessna Flyer Association	3126	CST Flight Services	3101
Cessna Flyer Association & Piper Flyer Association. - The #1 choice -	3126	CU Student Choice	4060
Cessna Owner Organization/Piper Owner Society	3164	CubCrafters Group - 40 Year Anniversary	272-274
CFM AVIATION SRL	448	Custom Computer Services, Inc.	1045
Champion Aerospace LLC	1014; 1015	Cutco (Vector Marketing)	765
ChargerGoGo	790	D	
Chart it All LLC	3172	Daher Aircraft	387
Checkers Safety	4055	DAJO Adventure Gear, LLC	4036
Cicare USA	932	Dakota Cub Aircraft - 10 Year Anniversary	384; 385
ciES Inc	3119	DARcorporation	3072C
Cirrus Aircraft	183	David Clark Company Inc. - 30 Year Anniversary	3092
Cirrus Owners and Pilots Association (COPA)	3166; 3167	David UHL Studios, Inc. - 10 Year Anniversary	2095-2097
Civil Air Patrol	54; 55	Delta Air Lines, Inc.	501
Ckd.Aero	404; 419	Delta Strut	1077
ClampTite Tools LLC	2071	Deltahawk Engines, Inc.	226-228
Clarity Aloft Aviation Headsets	3095; 3096		

Wing⁷ On-demand drone delivery

Wing is an aviation company that provides drone delivery as a faster, safer, and cleaner way to transport everyday goods. The company has built a small, lightweight, electric aircraft that can deliver food, medicine, and household items directly to homes in minutes. Since 2012, Wing has safely completed more than 350,000 commercial deliveries in North America, Europe, and Australia.



SAFETY Wing has flown more than 350,000+ flights to confirm the safety of our operations — safety is our highest priority.



PRIVACY There is no live feed of any imagery to anyone, including pilots overseeing operations. Cameras on board are low-resolution.



ENVIRONMENTAL When a customer orders a box of pasta from Wing, they use more energy boiling the water than we use delivering the product.



SERVICE Customers typically receive their orders in 30 minutes or less.



CONGESTION Drone deliveries can replace some trips to the store, meaning fewer vehicles on the roadways and less traffic on local streets.



ECONOMIC Drones can help connect businesses and customers, enabling local shops to expand their footprint for delivery and serve a wider population.



CERTIFIED Wing holds a Part 135 Air Carrier Certificate, which is the same level of certification as many commercial airliners.

LEARN MORE AT [WING.COM](https://wing.com)
FIND WING AT BOOTH 4115

@wingdronedelivery @Wing
 @Wing @Wing @Wing

EXHIBITORS

EXHIBITOR BOOTH KEY	BOOTH	EXHIBIT AREA	MAP PAGE
	1-505	Main Aircraft Display	58-59
	600-650	Homebuilt Aircraft Display	60
	700-832	Fly Market, Aeromart	60
	900-953	Ultralight/Rotorcraft Display	61
	1001-1160	Aircraft Spruce & Specialty Exhibit Hangar A	62
	2001-2161	Co-Pilot Goose Exhibit Hangar B	64
	3000-3176	Epic Aircraft Exhibit Hangar C	66
	4001-4114	DeltaHawk Engines Exhibit Hangar D	68
	E1-E30	EAA Education and Career Center presented by Piedmont Airlines	58
	IFP1-IFP22	International Federal Pavilion (Inside Exhibit Hangar D)	68
	C1-C26	EAA Career Center presented by Air Wisconsin Airlines	58
	SPB	EAA Seaplane Base presented by Wipaire	
	39-72 A & B	Aviation Gateway Park presented by Piper Aircraft, Inc.	58
WV1-WV14	EAA WomenVenture Center	58	

RED COMPANY NAMES Celebrating an AirVenture participation milestone anniversary
BLUE COMPANY NAMES New to AirVenture as an exhibitor
GREEN BOOTH #S Participating in the Aviation Job Fair supported by JSfirm.com

COMPANY	BOOTH #	COMPANY	BOOTH #
Departamento Aeroportuario	2132-2134	Eagle Fuel Cells	3103
Designs and Imports by Peach	776	EarthRoamer	822
Desser Aerospace	1035-1037	EarthX Inc	3159
Detroit Torch LLC	797A	Eastern Iowa Airport Aviation Workforce Development Campus	E18
DFWairparts.com	827	eDispatched	1063
DGPilot	4062	Eight Flight LLC	3080
Diamond Aircraft Industries Inc.	9	EKOLOT LLC (NIU Group)	938A
Diamond Doors	1039-1041	ELA Aviación, S.L.	341; 904
Discover Oshkosh - Oshkosh Aviation Park	3153-3156	Eldorado Trailer Sales LLC	826; 828; 829
Dog Tags	769	Electric Pedals Inc	712-714
DOT – Transportation Safety Institute	IFP-4; IFP-16	Electroair Acquisition Corporation	3144; 3145
Drake Aircraft Adventures	330, 337	Electronics International Inc.	1148; 1149
Dragon PPG, LLC	918	Elivate Aircraft	779
DRMIDWEST LLC	718	Elixir Aircraft	17-19
DUC Propellers USA, INC	426	Elizabeth The Gold Lady - 30 Year Anniversary	3090
Duluth Trading Company	3072	Elmarx Aviation Inc.	725
Dyna Tech	770	E-MAG Ignitions	1141; 1142
Dynamic Solutions Systems, Inc.	3127	Embry-Riddle Aeronautical University	49
DynaVibe and DryBot by RPX Technologies	1131; 1132	Endeavor Air	C13; C14
Dynon Avionics Inc.	496; 4034; 4035; 4035A; 4035B	EnerSys	1042
E		Enhanced Aero LLC.	4110
EAA AeroEducate Center	72A; 72B	Enstrom Helicopter Corporation	333
EAA Airline Crew HQ	466B	Envoy Air	C21; C22
EAA Canadian Council	400A	Epic Aircraft, LLC	235
EAA Canadian Headquarters	400	ESC Photography LLC	745
EAA Chapters, Young Eagles, and Programs	Chapters	ESiT Aviation Scales	4056
EAA C-PLAN	400B	Evoke Aircraft Design	615
EAA Insurance Solutions	262A	Evolution / Revo	931
EAA Learn to Fly Center	EAA4	Evolution Aircraft Company	275; 276
EAA Lifetime Member Oasis	EAA5	Executive Aircraft / ARGON Aircraft	900
EAA Member Center	EAA3	E-Z-GO	78
EAA Programs & Services	WV4; WV9	F	
EAA Retail Merchandise	EAA1; Merch1 -Merch5	Factory Direct Models	1152; 1153
EAA Wright Sim	IFP-14	Falken Avionics, LLC	1043
EAA Youth Welcome Center	EAA2		



BUILDING ENGINES SINCE 1929

WILLIAMSPORT, PENNSYLVANIA



© 2024 Avco Corporation

@LycomingEngines
www.Lycoming.com



SCAN to **FOLLOW US** & to see
our full 2024 EAA Airventure
Oshkosh schedule

BOOTH 277-282

EXHIBITORS

EXHIBITOR BOOTH KEY	BOOTH	EXHIBIT AREA	MAP PAGE
	1-505	Main Aircraft Display	58-59
	600-650	Homebuilt Aircraft Display	60
	700-832	Fly Market, Aeromart	60
	900-953	Ultralight/Rotorcraft Display	61
	1001-1160	Aircraft Spruce & Specialty Exhibit Hangar A	62
	2001-2161	Co-Pilot Goose Exhibit Hangar B	64
	3000-3176	Epic Aircraft Exhibit Hangar C	66
	4001-4114	DeltaHawk Engines Exhibit Hangar D	68
	E1-E30	EAA Education and Career Center presented by Piedmont Airlines	58
	IFP1-IFP22	International Federal Pavilion (Inside Exhibit Hangar D)	68
	C1-C26	EAA Career Center presented by Air Wisconsin Airlines	58
	SPB	EAA Seaplane Base presented by Wipaire	
	39-72 A & B	Aviation Gateway Park presented by Piper Aircraft, Inc.	58
WV1-WV14	EAA WomenVenture Center	58	

RED COMPANY NAMES Celebrating an AirVenture participation milestone anniversary
BLUE COMPANY NAMES New to AirVenture as an exhibitor
GREEN BOOTH #S Participating in the Aviation Job Fair supported by JSfirm.com

COMPANY	BOOTH #	COMPANY	BOOTH #
FEAM Aero	C3	Gallagher Aviation LLC	2136; 2137
FedEx	171	Game Composites LLC	380; 381
Fielden Aero, LLC	922	Garmin	347
Finnoff Aviation Products	322	Gary's Garage	777
Fit 4 Flight Coaching	4084	GE Aerospace	373-376
Flaggpole Farm	3161	General Aviation Manufacturers Association (GAMA)	299
Flight Design/Airtime Aviation Inc.	382	General Aviation Modifications Inc	3005
Flight Flix LLC	3136	Generation Global	825
Flight Lines LLC	2093	Genesys Aerosystems	3058AA
Flight Outfitters - 10 Year Anniversary	2039; 2040; 292A	Gift of Wings Inc	2050-2052
Flightclub.life	726	Gleim Aviation	1104-1106
FlightHelmet.com	3104; 3105	GoJet Airlines	C12
FlightSafety International - 30 Year Anniversary	1056-1058	Graphic Design	808-810
FlightSense	E19	Green Bay Austin Straubel Int. Airport	3143
Flitz International Ltd	1044	Grex Power Tools	2118; 2118A
Floats & Fuel Cells, Inc - 40 Year Anniversary	1119	Grove Aircraft Landing Gear Systems Inc.	1145
Flyboy LLC	644	GRT Avionics, Inc.	3068; 3069
Flycorvair.com	614	GSE America	823
Flying Eyes Optics	422; 423	Gulf Coast Avionics Corporation	2029; 2030
Flying Legend USA Inc - 10 Year Anniversary	639	Gulfstream Aerospace Corporation	85
Flying Media Group	440; 441	Gyro Technic LLC	920; 921
Flying Z Inc. Chicago Kite & Flag	807		
Flyinn Tours New Zealand	2152		
Fly-Inn, LLC	794	H	
FlySto.net	1013	Hangar	4111
Footpharmacy Direct	767	Hartwig Aircraft Fuel Cell Repair	3072DD
ForeFlight	747B	Hartzell Engine Tech	1111
Forge Flightworks	4005	Hartzell Propeller Inc.	296; 297
Fox Valley Technical College	E15	Hawk Airsports	911
FP-PROPELLER srl	3113	Hazebuster Optics	1130; 2001; 4114
FRASCA - 30 Year Anniversary	56	Healing of the Nations, LLC	729
Freight Runners Express	C10	Heavenbound Aviation	943; 944
Frontier Precision Unmanned	3141	Heaven's Landing, LLC	2098
		Helicycle Ventures LLC	928
		HEM INC. / HE&M Saw	814
		Herber Aircraft Service Inc	1140
G		High Country Products, Inc	798
G & N Aircraft Inc - 30 Year Anniversary	3024		



HOLY
MICRO! LLC



SkyVoice Alert 500

- 590 ft Takeoff & Landing Height Announcer for All Aircraft
- Gear Warning from 560 ft & Five Reminders
- Bluetooth or Wired
- Quick Install Option

SkyVoice Glassy Guide 400

- 400 ft Takeoff & Landing Height Announcer for Seaplanes
- Up to Four Gear Reminders
- Bluetooth or Wired
- 45° FoV



SkyVoice Lite

- Portable Takeoff & Landing Height Announcer for All Aircraft
- Bluetooth Audio



VISIT US! | EAA AirVenture Oshkosh
Booth Hangar A #1098

**Discounts
& Promos!**

315-362-9820 | info@holymicro.com | www.holymicro.com

EXHIBITORS

EXHIBITOR BOOTH KEY	BOOTH	EXHIBIT AREA	MAP PAGE
	1-505	Main Aircraft Display	58-59
	600-650	Homebuilt Aircraft Display	60
	700-832	Fly Market, Aeromart	60
	900-953	Ultralight/Rotorcraft Display	61
	1001-1160	Aircraft Spruce & Specialty Exhibit Hangar A	62
	2001-2161	Co-Pilot Goose Exhibit Hangar B	64
	3000-3176	Epic Aircraft Exhibit Hangar C	66
	4001-4114	DeltaHawk Engines Exhibit Hangar D	68
	E1-E30	EAA Education and Career Center presented by Piedmont Airlines	58
	IFP1-IFP22	International Federal Pavilion (Inside Exhibit Hangar D)	68
	C1-C26	EAA Career Center presented by Air Wisconsin Airlines	58
	SPB	EAA Seaplane Base presented by Wipaire	
39-72 A & B	Aviation Gateway Park presented by Piper Aircraft, Inc.	58	
WV1-WV14	EAA WomenVenture Center	58	

RED COMPANY NAMES Celebrating an AirVenture participation milestone anniversary
BLUE COMPANY NAMES New to AirVenture as an exhibitor
GREEN BOOTH #S Participating in the Aviation Job Fair supported by JSfirm.com

COMPANY	BOOTH #	COMPANY	BOOTH #
Hi-Tech Foams	1061	Javron Inc.	358; 359
Hobbs Flyer, LLC	1097	Jeppesen, A Boeing Company - 30 Year Anniversary	747A
Homestead Timber Frames	824	Jet Access	395
Honda Aircraft Company, LLC - 20 Year Anniversary	407	Jet Shades, LLC	4070; 4071
Honda Generators - Kitz & Pfeil Inc.	739; 760	Jimmy's World LLC	475A
Honeywell Aerospace Technologies	289	JME Technologies, Inc.	1017
Hooker Custom Harness, Inc.	1019	Joby Aviation	190
Horizon Hobby, LLC - 20 Year Anniversary	505	JP Instruments	1071-1073
HORIZONS AMERICA INC	758; 759	JSfirm.com	C15
Howard Seaborne	3111	Just Aircraft, LLC	925
Huffy's Airport Windssocks Inc.	4045		
Human Touch	1033; 1034	K	
Hytech Marketing	2108; 2109	Kanardia Avionics North America	2055
		Kansas State University Salina, Aerospace and Technology Campus	E29
I		Kelly Aerospace Thermal Systems	189
I BEAM SLIDING DOORS	2149; 2150	Kelly Manufacturing Company	3029
I.C.P. North America LLC	636	KG Wholesale LLC	756; 757
Icom America	2027; 2028	Kilo Charlie Aviation	311
Icon Wallets	786	King Schools Inc	2138-2140
IEEE	3158	Kip Motor Company / Kip Aero	310
iFly EFB by Adventure Pilot	3052; 3053	Kitchen Craft	738
Imprint Promotions LLC	735	Kitfox Aircraft LLC	600; 601; 622; 623
InEarz Sport	3160	Koala T Creations	797B
Infinite Flight, LLC	3027	Koenig Products Int'l, Inc.	3084; 4037
Infinity Massage Chairs	3137	KOLB AIRCRAFTCO.LLC	924
Insight Instrument Corporation	4093; 4094	KOMBI BRAZIL INC	97
Intermountain Business Insurance	2064; 2065	KSCanuck LLC	3010
International Association of Missionary Aviation	20	Kubick Aviation Services	1077; 1078
International Comanche Society Inc.	312		
International Homes of Cedar	4073; 4074	L	
International Society of Women Airline Pilots	WV8	Lake Michigan Credit Union	3129
International Visitors Tent	397-399	Lamar Technologies LLC	1046
		Last Glue (The)	1135; 3099
J		Latino Pilots Association (LPA)	WV7
JAARS, Inc	23	Leadership in Flight Training Academy, LLC	67; 68
Jabiru LSA	99	Leading Edge PPG	901



NEW ADVENTURES. NEW HEIGHTS.

Our aircraft are industry leaders and so are our people. If you're ready to elevate your career, visit Gulfstream at EAA Airventure Oshkosh 2024 from 10 a.m.-3 p.m. at booth #85 to connect with our talent acquisition team. Scan the QR Code to learn more about careers at Gulfstream.



Gulfstream Aerospace is an Equal Employment Opportunity (EEO) employer. It is the policy of the company to provide equal employment opportunities to all qualified applicants without regard to race, color, religion, sex, sexual orientation, gender identity, national origin, age, protected veteran or disabled status.

GulfstreamTM
A GENERAL DYNAMICS COMPANY

EXHIBITORS

EXHIBITOR BOOTH KEY	BOOTH	EXHIBIT AREA	MAP PAGE
	1-505	Main Aircraft Display	58-59
	600-650	Homebuilt Aircraft Display	60
	700-832	Fly Market, Aeromart	60
	900-953	Ultralight/Rotorcraft Display	61
	1001-1160	Aircraft Spruce & Specialty Exhibit Hangar A	62
	2001-2161	Co-Pilot Goose Exhibit Hangar B	64
	3000-3176	Epic Aircraft Exhibit Hangar C	66
	4001-4114	DeltaHawk Engines Exhibit Hangar D	68
	E1-E30	EAA Education and Career Center presented by Piedmont Airlines	58
IFP1-IFP22	International Federal Pavilion (Inside Exhibit Hangar D)	68	
C1-C26	EAA Career Center presented by Air Wisconsin Airlines	58	
SPB	EAA Seaplane Base presented by Wipaire		
39-72 A & B	Aviation Gateway Park presented by Piper Aircraft, Inc.	58	
WV1-WV14	EAA WomenVenture Center	58	

RED COMPANY NAMES Celebrating an AirVenture participation milestone anniversary
BLUE COMPANY NAMES New to AirVenture as an exhibitor
GREEN BOOTH #S Participating in the Aviation Job Fair supported by JSfirm.com

COMPANY	BOOTH #	COMPANY	BOOTH #
LeafFilter Gutter Protection	1099; 1100	METARmaps, LLC	1092; 1093
Lear Chemical Research Corp	2010	Method Seven	3043; 3044
Lee Aerospace, Inc.	168; 176	MGL Avionics - 20 Year Anniversary	3089
Legendary Aviation Coffee Company LLC	4054	Michelin North America, Inc.	434-436
LeTourneau University	39; 47; 48	Micro AeroDynamics Group Inc	3040
Levil Aviation	3074; 3075	Microair Avionics Pty Ltd	4001; 4002
Lewis University	53	Mid-Continent Instruments & Avionics	2007
LGM USA	773; 774	Middle Tennessee State University	442; 461
Liberty University, Inc.	60	Mid-State Aerospace, Inc.	3050
Life Builders International	1006	Midwest Ear	708
LIFT Aviation	339	Midwest Eco Pavers LLC	4101
Light Painting by Michael Anderson Photography	3064	Midwest Parajet LLC - 10 Year Anniversary	901A
Lightspeed Aviation	259	Midwest Pepper Heads LLC	764
Lilla Rose/Joan's Beautiful Hair Boutique	753	Mike Goulian Airshows, Inc.	488
Lincoln Electric - 30 Year Anniversary	469-471	Miller Clock Service, Inc. - 20 Year Anniversary	1062
Lockwood Aircraft Corp / AirCam	2009	Minimax Aircraft Tugs	2026
Lone Mountain Aircraft	3070	Minnesota Pneumatic Products	811; 812
Loree Air, Inc.	2061	Minnesota State University, Mankato Aviation	E24
LP Aero Plastics Inc	1116; 1117	Mission Aviation Fellowship (MAF)	22; C19
LX Navigation d.o.o.	3157	Mittler Corporation	1094-1096
LX7 Aircraft	314	Moody Aviation / Moody Bible Institute of Chicago	21
Lycoming Engines	277	MotoArt PlaneTags LLC.	2021-2023
M		Mountain High Aviation Oxygen	3073
M&E Sales	2068-2070	M-Squared Aircraft, Inc	952
M.A.V. SRL	4076	MT-Propeller Entwicklung GmbH	2014; 2015
Mac's Custom Tiedowns	821	MTS Aviation Models	748; 751; 752; 746A
Magni Gyro, srl	438; 929	Murphy Aircraft	405; 406; 629
magniX	324; 325; 342; 343	Myers Aviation LLC	624
MasterPilot	4086	MYGOFLIGHT	1038; 3135; 3136
Matco Aircraft Landing Systems LLC	643	MyPilotPro	1048; 1049
Maule Air, Inc	135	MzeroA Online Ground School	2114; 2115
McCaughey Propeller Systems	78	N	
MCE Aero	1107	NASA - 30 Year Anniversary	NASA
McFarlane Aviation, LLC	3131; 3121B; 3121E	National Air Traffic Controllers Association	466
Met-All Industries	1101	National Association of Flight Instructors, Inc.	354; 355

uAvioni 



**EAA AIRVENTURE
OSHKOSH
2024**

**Find us at
EAA AirVenture
Oshkosh 2024**

BOOTH 3045/3046 | SUPPORT TENT 195A



LEARN MORE ABOUT OUR
**TRAINING SESSIONS &
SHOW SPECIALS**



EXHIBITORS

EXHIBITOR BOOTH KEY	BOOTH	EXHIBIT AREA	MAP PAGE
	1-505	Main Aircraft Display	58-59
	600-650	Homebuilt Aircraft Display	60
	700-832	Fly Market, Aeromart	60
	900-953	Ultralight/Rotorcraft Display	61
	1001-1160	Aircraft Spruce & Specialty Exhibit Hangar A	62
	2001-2161	Co-Pilot Goose Exhibit Hangar B	64
	3000-3176	Epic Aircraft Exhibit Hangar C	66
	4001-4114	DeltaHawk Engines Exhibit Hangar D	68
	E1-E30	EAA Education and Career Center presented by Piedmont Airlines	58
	IFP1-IFP22	International Federal Pavilion (Inside Exhibit Hangar D)	68
	C1-C26	EAA Career Center presented by Air Wisconsin Airlines	58
	SPB	EAA Seaplane Base presented by Wipaire	
	39-72 A & B	Aviation Gateway Park presented by Piper Aircraft, Inc.	58
WV1-WV14	EAA WomenVenture Center	58	

RED COMPANY NAMES Celebrating an AirVenture participation milestone anniversary
BLUE COMPANY NAMES New to AirVenture as an exhibitor
GREEN BOOTH #S Participating in the Aviation Job Fair supported by JSfirm.com

COMPANY	BOOTH #	COMPANY	BOOTH #
National Aviation Academy	460	Olympus Machinery Group	4105
National Business Aviation Association	432; 433	One Mile Up, Inc.	1003; 1004
National Gay Pilots Association	2046-2048	Oplite / Machine Incorporated	2062
National Museum of the U.S. Air Force	IFP-12; IFP-15	Oregon Aero Inc - 30 Year Anniversary	4063-4067
National Nuclear Security Administration-NNSA	IFP-6; IFP-18	Organization of Black Aerospace Professionals	WV11
National Park Service	IFP-13; IFP-19	Original Safety Siphon (The) - 10 Year Anniversary	719
National WASP WWII Museum - 10 Year Anniversary	WV3	Oris Watches USA, Inc	3042
Nectar of the Vine	2012	Orlican Americas - Eagle M8	953
Neptune Aviation Services	E3	Oshkosh Airport Products	372
NetJets Inc	C16	Oshkosh Congregation of Jehovah's Witnesses	716
New England Aero Services, Inc.	2157; 2158		
New Pacific Airlines	C5	P	
Nexair Avionics LLC	317	Pacific Coast Avionics Corp	2031; 2032
NGPA - Women's Committee	WV6	Pacific Oil Cooler Service	3063
Nicholas Air	219	Para-Phernalia, Inc. - 40 Year Anniversary	3133
Nifty-Lift	709	Park Rapids Aviation, Inc	SPB3
Ninety Nines, Inc (The)	2120; 2121; WV14	Parker - 30 Year Anniversary	3138
NMDOT Aviation Division	4090; 4091	Parkland College - Institute of Aviation - 10 Year Anniversary	3041
NOAA/Aviation Weather Center	IFP-1	Pecan Plantation	4059
NOAA/Search and Rescue Satellite-Aided Tracking (SARSAT) Program	IFP-2	PEDAL PLANES by AVIATION PRODUCTS	499
Noble Flight Solutions	E25	Pegasus	400F
North America Eagle, Inc	923	Pelegrin LLC	96
North American Aerospace Defense Command - 20 Year Anniversary	IFP-7	PENFED Credit Union	270
NorthPoint Aviation	195B; 3114-3116	Petro Nuts	818
Northwest Mfg PowerTow	3110	Phillips 66 Company	430; 431
Novah LLC	755; 2091; 2092	Phoenix East Aviation, LLC - 10 Year Anniversary	52
novoFlight Technologies	2153	Phoenix Replica Aircraft	832
NUNCATS CIC	621	Piedmont Airlines	C24; C25
Nuvite Chemical Compounds	1121	Pik West Insurance Agency, LLC	2135
		Pilatus Business Aircraft Ltd	124
O		Pilot Communications USA	1030
Oakley / Rayban	799	Pilot Institute	209; 210; 2141
Oasis Scientific, Inc.	3102	Pilot Mental Health Campaign (PMHC)	2002; 2003
Oklahoma Department of Commerce	3139; 3140	Pilots Cross (The)	3011
Oklahoma State University	42	Pilots For Christ, Minnesota Chapter	4038; 4039
		PilotSafety.org - 10 Year Anniversary	3134

E1000

GX

FILL IT UP.
GO THE DISTANCE.
FAST.

2,860 lb Useful Load | 1,100 lb Max Full Fuel Payload | 1,560 nm Max Range | 333 ktas Max Cruise

Visit us on Celebration Way.



Scan for updated US Demo
Tour dates and locations

 EPIC
epicaircraft.com

EXHIBITORS

EXHIBITOR BOOTH KEY	BOOTH	EXHIBIT AREA	MAP PAGE
	1-505	Main Aircraft Display	58-59
	600-650	Homebuilt Aircraft Display	60
	700-832	Fly Market, Aeromart	60
	900-953	Ultralight/Rotorcraft Display	61
	1001-1160	Aircraft Spruce & Specialty Exhibit Hangar A	62
	2001-2161	Co-Pilot Goose Exhibit Hangar B	64
	3000-3176	Epic Aircraft Exhibit Hangar C	66
	4001-4114	DeltaHawk Engines Exhibit Hangar D	68
	E1-E30	EAA Education and Career Center presented by Piedmont Airlines	58
	IFP1-IFP22	International Federal Pavilion (Inside Exhibit Hangar D)	68
	C1-C26	EAA Career Center presented by Air Wisconsin Airlines	58
	SPB	EAA Seaplane Base presented by Wipaire	
39-72 A & B	Aviation Gateway Park presented by Piper Aircraft, Inc.	58	
WV1-WV14	EAA WomenVenture Center	58	

RED COMPANY NAMES Celebrating an AirVenture participation milestone anniversary
BLUE COMPANY NAMES New to AirVenture as an exhibitor
GREEN BOOTH #S Participating in the Aviation Job Fair supported by JSfirm.com

COMPANY	BOOTH #	COMPANY	BOOTH #
Pilotsmith, Inc	44	R	
Pinnacle Aircraft Engines	427; 428	R & M Steel Company	4047; 4048
Pioneer Control Grips	1102	R.A. Miller Industries Inc.	3117; 3118
Piper Aircraft, Inc. - 30 Year Anniversary	140	RAA an Allworth Company	2049
Piper Flyer Association	3126	Rachel's Jewelry, LLC - 10 Year Anniversary	789
Pipistrel by Textron eAviation	78	Rainbow Aviation Services	1143
Pitman Air LLC	934	Raisbeck Engineering Inc.	2020
Pivotal Aero, LLC	361; 362	RANS Designs, Inc	606; 607; 616
Plane Baby LLC	3083	Rapco, Inc.	2090
Plane Plastic Vantage Assoc - 20 Year Anniversary	1136; 1137	Ray Allen Company, Inc.	2045
Plane-Power/Sky-Tec	1113	RayTalk Communications Ltd	1103
PlaneSense, Inc.	C6	RCW Wholesale INC.	721; 722
PMA Products, Inc.	3123	Real de Talpa	717
Poly Fiber, Inc.	1151	Real Time Pain Relief	801
Poplar Grove Airmotive	4113	RealSimGear, Inc.	2159-2161
Porter County Regional Airport - 10 Year Anniversary	4112	Rebex Cutlery	793
Porto Aviation Group	193	Red Box Tools And Foam	3072B
Power Flow Systems, Inc	1050; 1051	Red Tag Art	815
PowerLift Hydraulic Doors 1127-1129; 2154-2156; 3015-3017; 4041-4044		Redbeards Tools	703
Powrachute LLC - 20 Year Anniversary	937	Redbird Flight	301
PPG	2142-2144	Remote Area Medical - RAM(R)	3108
Pratt & Whitney Canada 2102-2107; 2125-2127; 2129-2131		Republic Airways	C20
PreFlight LLC	218	Republic Bank	3054
Prestige Products Direct/Triad Aer	4053	Resinwerks	2079
Prochoc LLC	1157	Retailainers LLC	1147
Professional Aviation Safety Specialists	2151	Ridge Landing Airpark	1052
Progressive Air Group	400G	Rinehart Fine Arts and Historic Collectibles	1031; 1032; 1033A
PROSERV AVIATION	823	RJT, LLC	782; 783; 795; 796
Prusa Research, a.s. - 10 Year Anniversary	4107	RODMAN DRILL	772
PS Engineering Inc	1020; 1021	Rope Chocks LLC	2067
PSA Airlines - 10 Year Anniversary	C9	Rotax iService and Training Centers	265
Purdue University School of Aviation & Transportation Technology	61; 62	Rotax Service Center / Lockwood Aviation Supply Inc	2008
		Rotec Aerosport Pty Ltd	647
Q		runway THREE-SIX - 10 Year Anniversary	791; 792
Quality Aircraft Accessories	1112	RUPES USA, Inc.	2034
Quiet Technologies, Inc	3055; 3056	Rustic Oak	780

Imagine a Career You Love!



Working as an airline pilot is not only a great way to earn a living—it's fun.

Talk this week with members of the Air Line Pilots Association, Int'l (ALPA), the largest airline pilot union in the world, about how you can get started.

*We're located at **booth #329** just blocks from Boeing Plaza.*

#ALPAatOSH24 #ClearedtoDream

Visit **alpa.org/oshkosh** for a list of this week's daily ALPA presentations and scheduled activities.

Also check out **clearedtodream.org** with tips and resources for aspiring airline pilots.

EXHIBITORS

EXHIBITOR BOOTH KEY	BOOTH	EXHIBIT AREA	MAP PAGE
	1-505	Main Aircraft Display	58-59
	600-650	Homebuilt Aircraft Display	60
	700-832	Fly Market, Aeromart	60
	900-953	Ultralight/Rotorcraft Display	61
	1001-1160	Aircraft Spruce & Specialty Exhibit Hangar A	62
	2001-2161	Co-Pilot Goose Exhibit Hangar B	64
	3000-3176	Epic Aircraft Exhibit Hangar C	66
	4001-4114	DeltaHawk Engines Exhibit Hangar D	68
	E1-E30	EAA Education and Career Center presented by Piedmont Airlines	58
	IFP1-IFP22	International Federal Pavilion (Inside Exhibit Hangar D)	68
	C1-C26	EAA Career Center presented by Air Wisconsin Airlines	58
	SPB	EAA Seaplane Base presented by Wipaire	
	39-72 A & B	Aviation Gateway Park presented by Piper Aircraft, Inc.	58
WV1-WV14	EAA WomenVenture Center	58	

RED COMPANY NAMES Celebrating an AirVenture participation milestone anniversary
BLUE COMPANY NAMES New to AirVenture as an exhibitor
GREEN BOOTH #S Participating in the Aviation Job Fair supported by JSfirm.com

COMPANY	BOOTH #	COMPANY	BOOTH #
S			
SAFE (Society of Aviation & Flight Educators)	2081; 2082	Sling Aircraft	648-650
Safran Innovation - CoSENSE AR	E13, E14	Sling Pilot Academy	E1; E2
Saint Louis University	38	SMA Aero Engines GmbH	830
Samaritan Aviation	SPB5	Small Town EV CO	802
Samson Sky	304; 305; 320; 321	Smithsonian - National Air and Space Museum	327
Sandia Aerospace Corporation	3058	SMR Technologies Ice Shield Deicing Systems - 20 Year Anniversary	3030; 3031
Sarasota Avionics	328; 2024; 2025	Snap-on Industrial	445; E11
Saudi Arabia's Sand and Fun General Aviation Forum '24	331; 332	Soaring Society of America, Inc.	377; 378
SayWeather	3082	SoCo Swings - 10 Year Anniversary	4008
ScaleBirds LLC	632	Sonex, LLC	602
Scheme Designers, Inc	3057	Sonic Tools	E16
Schweiss Distributing Inc	701; 4077-4080; 4095-4098	SoundEx Products/Plane Patterns - 10 Year Anniversary	1150
Scion Helicopters, LLC	129; 134	Southern Cross Aviation	315
scissortail aerosport, LLC.	454	Southern Illinois University	63; 64
Scout Aero	920	Southwest Airlines	502
Seaplane Pilots Association	3000-3002; SPB4	Southwestern Illinois College	E5
SEJK Services	784	SparrowHawk Mobile Detailing	2033
Seljan Tool Company	710	Spartan College of Aeronautics and Technology	192
Sensenich Propeller	3048; 3049	Spencer Aircraft Supply	383
SHARK.AERO	637; 638	Sport Performance Aviation LLC	620
Shenzhen CXD Science & Technology Co., Ltd.	740	SportairUSA, LLC	298
Sigtronics Corporation	1110	SportTruckRV	727; 728; 730; 731
Silverlight Aviation - 10 Year Anniversary	912	Sporty's Aviation Gifts	2110-2112
Silverwing At Sandpoint	1081	Sporty's Pilot Shop	260A; 260B
SIMCOM Aviation Training	2083	SPOT LLC	1018
SiriusXM Aviation	318	StandardAero	2011
Skeeter Enterprises LLC	259A	Star Blink Products	803
SKY DESIGNS AERO	946	Star Glow International	2066; 4057
Skyborne Airline Academy	E6	State of Minnesota - Aeronautics - 10 Year Anniversary	3078; 3079
SkyLab Engineering, LLC	613	SteinAir, Inc	3033; 3034
Skyryse	402; 403; 420; 421	Sterna Aircraft LLC	3080; 3081
SkyVoice Alert 500 - Holy Micro! LLC	1098	Stewart 51 Partner, LLC	631
Skyways	128	Stewart Systems - 20 Year Anniversary	926; 927
SkyWest Airlines, Inc.	C7; C8	STOR-LOC	2099; 2100
Slidedown Tiedowns	1083	Stratos Aircraft Inc.	15; 16



Discover the
**possibilities
today.**

Join CAE as an Instructor Pilot

Inspire future pilots through our advanced training technology and enjoy the comfort of home every night.

Scan the QR code to learn more.



www.cae.com/careers

CAE

EXHIBITORS

EXHIBITOR BOOTH KEY	BOOTH	EXHIBIT AREA	MAP PAGE
	1-505	Main Aircraft Display	58-59
	600-650	Homebuilt Aircraft Display	60
	700-832	Fly Market, Aeromart	60
	900-953	Ultralight/Rotorcraft Display	61
	1001-1160	Aircraft Spruce & Specialty Exhibit Hangar A	62
	2001-2161	Co-Pilot Goose Exhibit Hangar B	64
	3000-3176	Epic Aircraft Exhibit Hangar C	66
	4001-4114	DeltaHawk Engines Exhibit Hangar D	68
	E1-E30	EAA Education and Career Center presented by Piedmont Airlines	58
	IFP1-IFP22	International Federal Pavilion (Inside Exhibit Hangar D)	68
	C1-C26	EAA Career Center presented by Air Wisconsin Airlines	58
	SPB	EAA Seaplane Base presented by Wipaire	
39-72 A & B	Aviation Gateway Park presented by Piper Aircraft, Inc.	58	
WV1-WV14	EAA WomenVenture Center	58	

RED COMPANY NAMES Celebrating an AirVenture participation milestone anniversary
BLUE COMPANY NAMES New to AirVenture as an exhibitor
GREEN BOOTH #S Participating in the Aviation Job Fair supported by JSfirm.com

COMPANY	BOOTH #	COMPANY	BOOTH #
Stratus Financial	1123; 1124	Threads of Hope, Inc.	749
Strong Parachutes	1016	Thrust Flight & Thrust Institute of Maintenance	208
Summit Aviation LLC	4068; 4069	Timber Tiger Aircraft, Inc.	628
Summit Aviation MFG, Western Aircraft	371	Tipsy Foods	816
Sun Country Inc. dba Sun Country Airlines	C11	Titan Aircraft Supply	902
SUN 'n FUN, Inc. - 50 Year Anniversary	503; 3012; 3013	TL Sport Aircraft	306; 307
sunglass connection	1005	Tornado Alley Turbo, Inc	3006
Superflite, Inc.	3059	Tosten MFG	2124
Superior Air Parts, Inc. - 30 Year Anniversary	258	ToyFLEXX Miltech Incorporated	702
Superior Aircraft Components LLC	3148	Traeger Grills	4051; 4052
Superior Sleep Experience	3058C; 3058D	Transhield	356; 357
SureFly Partners, Ltd	1114; 1115	Transportation Security Administration	IFP-10
Swift Fuels LLC	455; 456	Transportation Security Administration Pre-Check	IFP-3
Sykl Power Bikes	733	TrickAir Skis	475
T		Trig Avionics Europe B.V.	3130
Tactical Hearing	3142	Trio Avionics	2113
TAE Aerospace	2038	True Blue Power	2005; 2006
Tag It Your Way	732	TruStep	787
Tailwinds / In The Pattern	2019	Tundra Tailwheels	910
Tanis Aircraft - 10 Year Anniversary	286	Turtle-PAC	3007
Tarragon Aircraft USA LLC	95	TWU - Aeronautical Sciences Dept.	E21
TCW Technologies LLC	4058	U	
Team Rocket Aircraft	645	U.S. Coast Guard Auxiliary	1134
Tecnam US Inc	247	U.S. Department of Veteran Affairs	228A
Tekton, Inc.	3093; 3094	U.S. Jaclean, Inc	831
Teledyne Battery Products	3003; 3004	uAvionix Corporation	195A; 3045; 3046
Telex Aviation	1085	UFlyMike	1108; 1109
TELY Technologies	1055	ULPower Aero Engines NV	633
Tempest Aero Group	3021-3023	Ultra-Prop LLC	935
Terral Aviation	3170	UMA Inc - 40 Year Anniversary	1060
teTra aviation corp.	625; 646	Uncommon USA Inc.	1069; 1070; 4087
Texas A&M University-Central Texas	E23	Underwriter's Salvage Company	2013
Textron Aviation	78; 393	United States Air Force Academy	E17
The Goodyear Tire & Rubber Company - 10 Year Anniversary	489	United States Army	43A-E
The Pink Jet	429	Univair Aircraft Corporation	1001; 1002



ABSOLUTELY ICONIC



UNMATCHED SPEED

Excellent aerodynamics enable all Risen models to achieve record breaking performance with very high economic cruising speeds unmatched by any other competitor



CUTTING EDGE TECHNOLOGY

State of the art aircraft with all carbon structure and glass cockpit with touch avionics and autopilot



COMFORT AND LUXURY

Unmatched majestic panoramic views and comfort on long flights thanks to a spacious cabin with a glass canopy and ergonomic leather seats

VISIT US AT **BOOTH 193**

The Risen creates a new aircraft segment that cannot be compared to any conventional aircraft. Its aerodynamics and state of the art technology allow it to harness the power of Rotax naturally aspirated and turbo-injected engines with the highest efficiency and performance on the market, enabling very high cruising speeds with the lowest fuel consumption. But the Risen also stands for comfort and luxury, with a spacious and ergonomic cabin, an electric canopy, glass-touch avionics, and superior lines and design. Porto Aviation Group Spa is listed on the Milan Stock Exchange (PAG) and its shares are freely traded in the Euronext Growth Milan segment, aimed at SMEs with high growth potential.



PORTO AVIATION GROUP

Porto Aviation Group

Via Confalonieri 22 - 23894 - Cremella (LC), Italy

+39 039 92 12 128

Risen Aircraft USA

barnes@portoaviationgroup.com

801.209.8851

www.portoaviationgroup.com | www.flyrisen.com

EXHIBITORS

EXHIBITOR BOOTH KEY	BOOTH	EXHIBIT AREA	MAP PAGE
	1-505	Main Aircraft Display	58-59
	600-650	Homebuilt Aircraft Display	60
	700-832	Fly Market, Aeromart	60
	900-953	Ultralight/Rotorcraft Display	61
	1001-1160	Aircraft Spruce & Specialty Exhibit Hangar A	62
	2001-2161	Co-Pilot Goose Exhibit Hangar B	64
	3000-3176	Epic Aircraft Exhibit Hangar C	66
	4001-4114	DeltaHawk Engines Exhibit Hangar D	68
	E1-E30	EAA Education and Career Center presented by Piedmont Airlines	58
	IFP1-IFP22	International Federal Pavilion (Inside Exhibit Hangar D)	68
	C1-C26	EAA Career Center presented by Air Wisconsin Airlines	58
	SPB	EAA Seaplane Base presented by Wipaire	
	39-72 A & B	Aviation Gateway Park presented by Piper Aircraft, Inc.	58
WV1-WV14	EAA WomenVenture Center	58	

RED COMPANY NAMES Celebrating an AirVenture participation milestone anniversary
BLUE COMPANY NAMES New to AirVenture as an exhibitor
GREEN BOOTH #S Participating in the Aviation Job Fair supported by JSfirm.com

COMPANY	BOOTH #	COMPANY	BOOTH #
University of Colorado Colorado Springs	E27	Wen Industries	3173
University of Dubuque	E9; E10	Wentworth Aircraft Inc	2087
University of North Dakota Aviation - 40 Year Anniversary	65	Western Michigan University - College of Aviation	45; 46
US Aviation Academy	E22	Whelen Aerospace Technologies, LLC - 40 Year Anniversary	1086-1088
US Fish and Wildlife Service Branch of Aviation Management	IFP-8; IFP-20-IFP-22	Wilderness Mint LLC	3163
US Sport Planes	98	Wiley Art - 10 Year Anniversary	SPB1
USAeroSports	951B	Williams International Co., L.L.C.	83
Utah State University Aviation Technology	72	Wing Armor	400E
Utah Valley University- Aviation	E7; E8	Wing Aviation	4115
V		Wing View Tint	4103; 4104
VACO Aviation, Inc.	933	wingnut publishing	630
Valdor Aircraft Inc.	169; 170	Wings Insurance	91; 92
Van's Aircraft, Inc.	604; 605; 618; 619	Wipaire, Inc.	162; SPB2
Vashon Aircraft	308; 309	Wisconsin Aviation, Inc. - 30 Year Anniversary	3162
Vaughn College of Aeronautics and Technology	E30	Wisconsin Department of Transportation Bureau of Aeronautics	473; 1125; 1126
Velocity Inc	634; 635	Women in Aviation International - 30 Year Anniversary	WW5; 2041-2043
Verizon Cellular Sales	742	Women Military Aviators, Inc.	WW2
Vertical Aviation International	363	Wood Art USA	805; 806; 3025
Vertical Power by Astronics	4049	World Famous Sunglasses	750
Viking Aircraft Engines	612	Worthington Aviation, LLC	4089
Vista America	4081; 4082	Wright Brothers Worldwide LLC (The)	1047
Vortic Watch Company	3169	X	
Vrontoulakis LTD	640	XFS Global LLC	736; 737
W		X-Naut LLC	3014
WACO Classic Aircraft Corporation - 40 Year Anniversary	253	Y	
WaLin Design	775	Yaesu USA - 30 Year Anniversary	2089
Walkabout Company (The)	3091	Z	
Wall Colmonoy/Microcraft	1007	ZClear Anti Fog Inc. - 20 Year Anniversary	1122; 2080
Wapsi Aero LLC	916	Zenith Aircraft Company	610; 611
Warbird Coffee Company	3168	Zipline	4007
Warp Drive, Inc	905; 906	ZJH Holdings	1012
WEFLO	43		
Weldon Pump LLC - 10 Year Anniversary	3066; 3067		
Well Bilt Industries	191		

LENS



CLEANER

FOLLOW US

@ZCLEARLENSCLEANER



WINDSHIELD, GLASSES AND LENS CLEANER



BOOTH 1122 | BOOTH 2080

COME TO SEE US AT EAA | JULY 22 TO JULY 28 AT OSHKOSH, WI

MAIN AIRCRAFT DISPLAY

Booths 1-503, C1-C26, E1-E30, and WV1-WV14

CAREER CENTER

Presented by Air Wisconsin Airlines

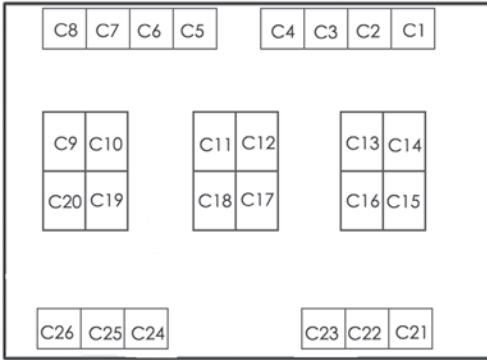

EDUCATION/CAREER CENTER

Presented by Piedmont Airlines

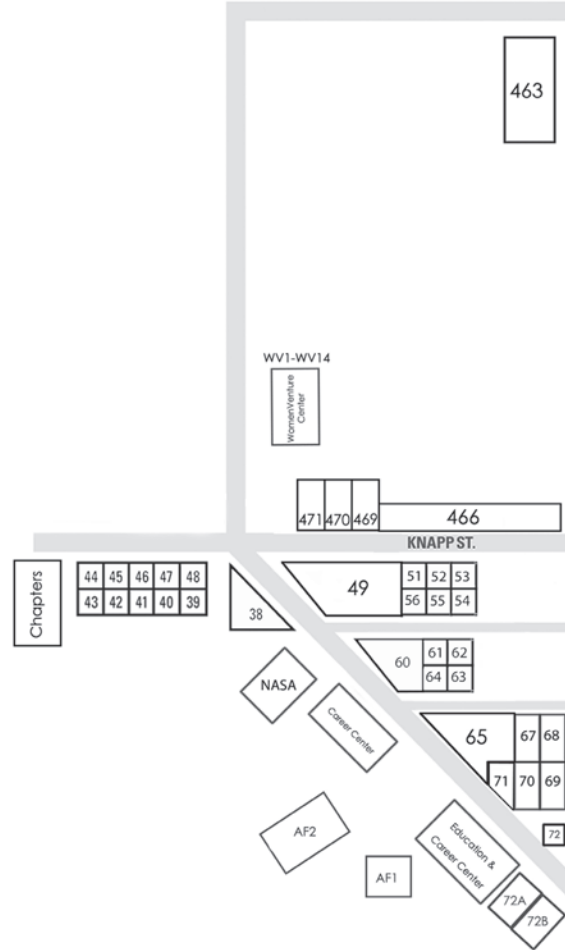



HOME BUILT AIRCRAFT DISPLAY

Booths 600-650

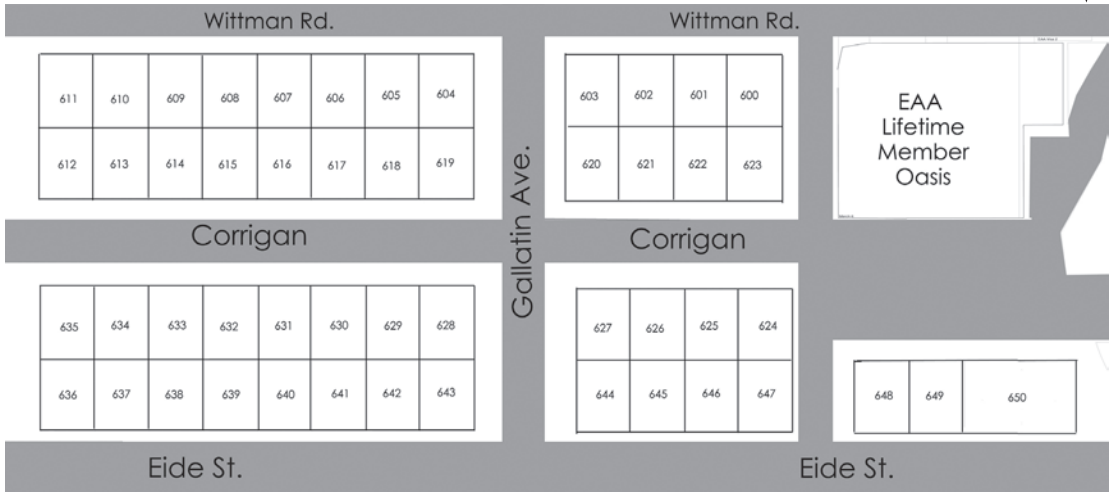

FLY MARKET AND AEROMART DISPLAY

Booths 700-832

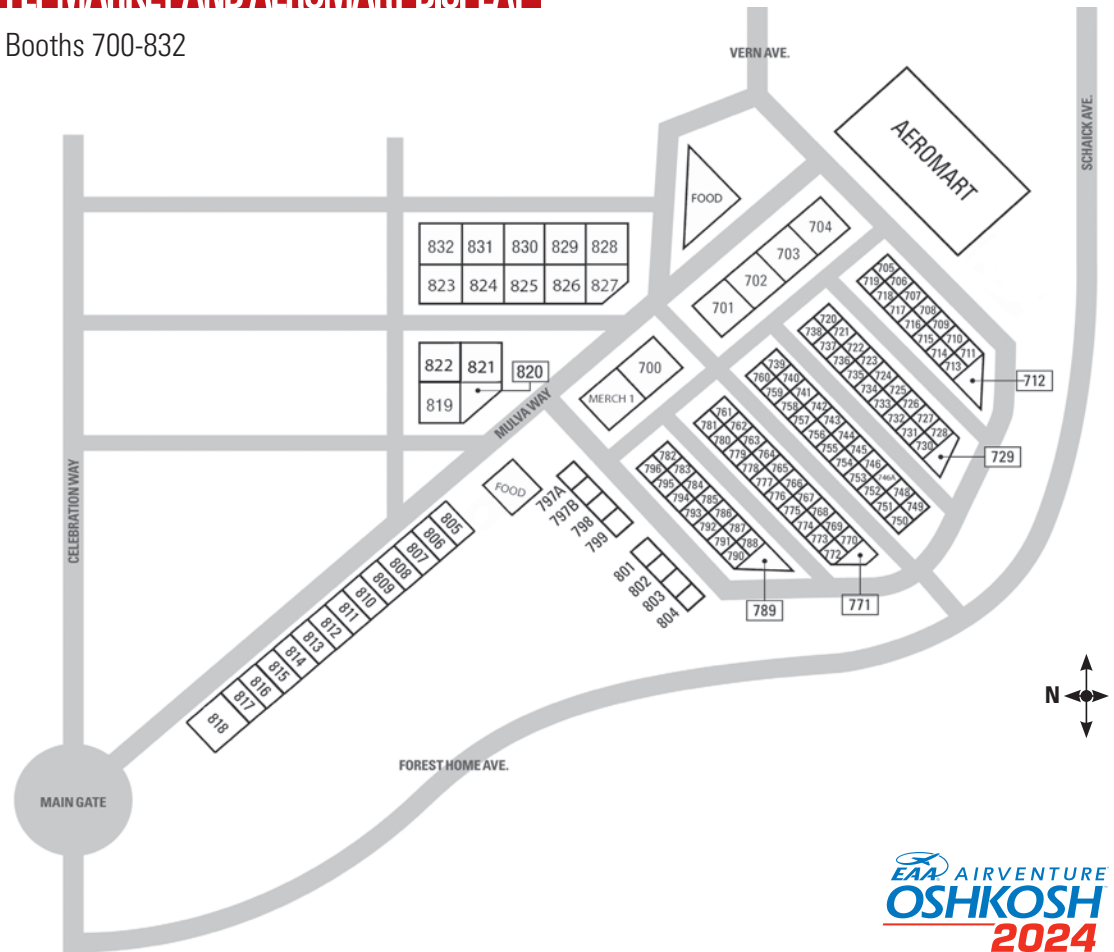

ULTRALIGHT/ROTORCRAFT DISPLAY

Booths 900-953



950
951
951B
952
953

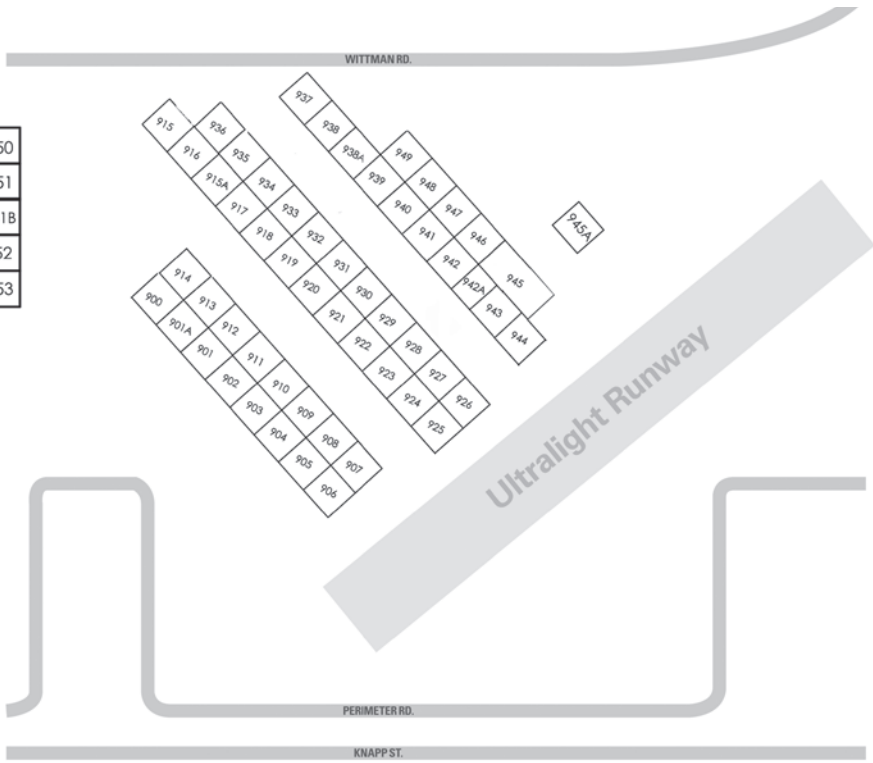

EAA® Four Corners

From first-time visitors to seasoned attendees, new EAA members to Lifetime, and aviation enthusiasts and pilots, the EAA Four Corners has something for everyone!

EAA Member Center

- > Join, renew, or become an EAA Lifetime member™
- > Explore EAA's many member programs and benefits
- > Get your photo taken at a photo op wall to commemorate your visit to Oshkosh
- > Play a game of members-only Plane-ko

EAA Learn to Fly Center

- > Enjoy daily "Learn to Fly" forums
- > Take an introductory flight lesson on a Redbird flight simulator
- > Apply for your student pilot certificate
- > Ask our friendly volunteers all your "Learn to Fly" questions!

EAA Youth Welcome Center

- > Learn about youth activities on the AirVenture® grounds
- > Take your picture in a fighter jet cockpit and rivet your own keychain
- > Explore EAA's youth education opportunities

EAA Merchandise

- > Pick up your favorite AirVenture souvenirs
- > Commemorate EAA® AirVenture® Oshkosh™ 2024 with event apparel



AIRCRAFT SPRUCE & SPECIALTY EXHIBIT HANGAR A

Booths 1001-1160

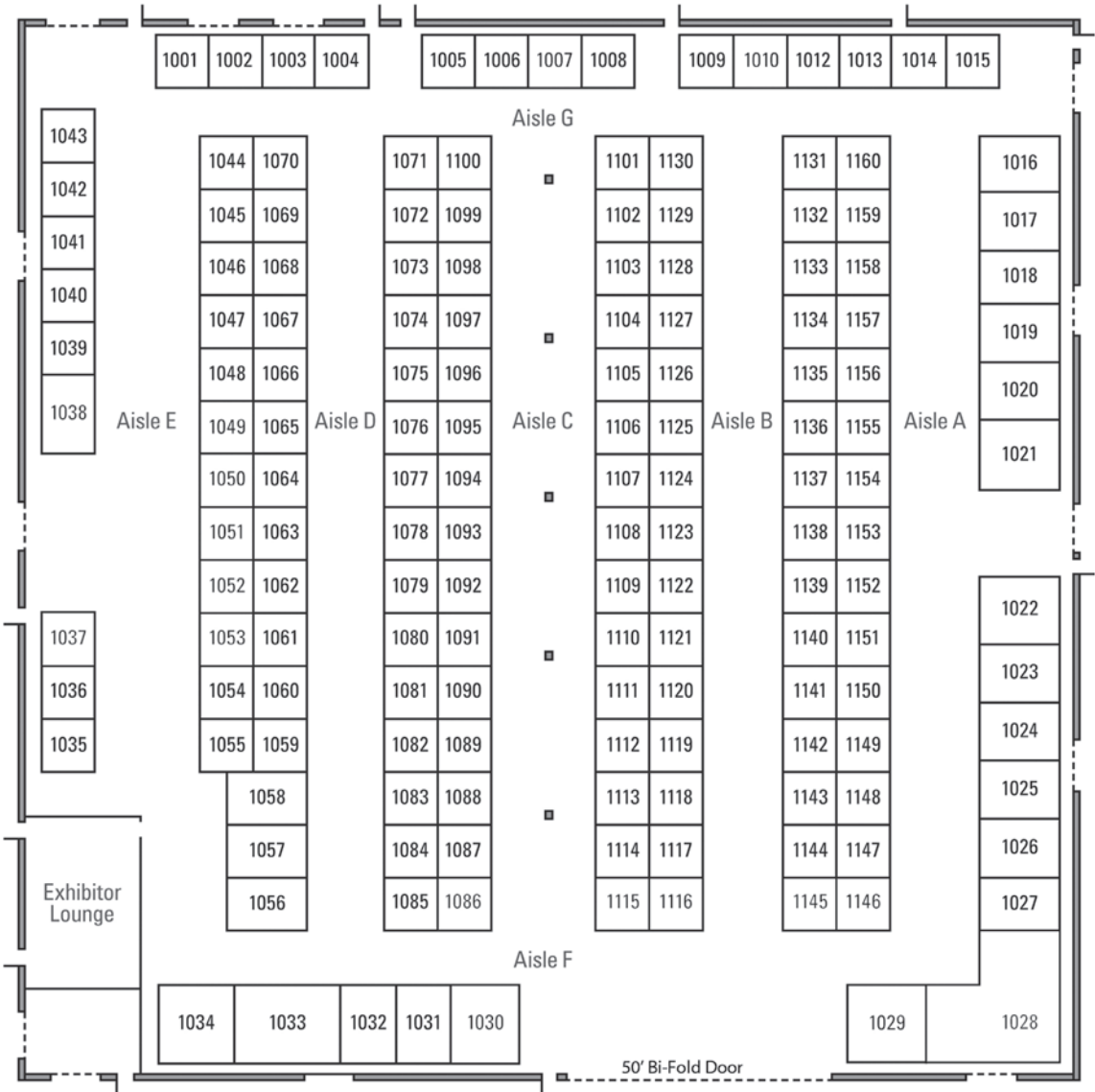



Our engines
power flight.

A love of flight
powers us.

We were meant to fly.



GE Aerospace

CO-PILOT GOOSE EXHIBIT HANGAR B

Booths 2001-2161

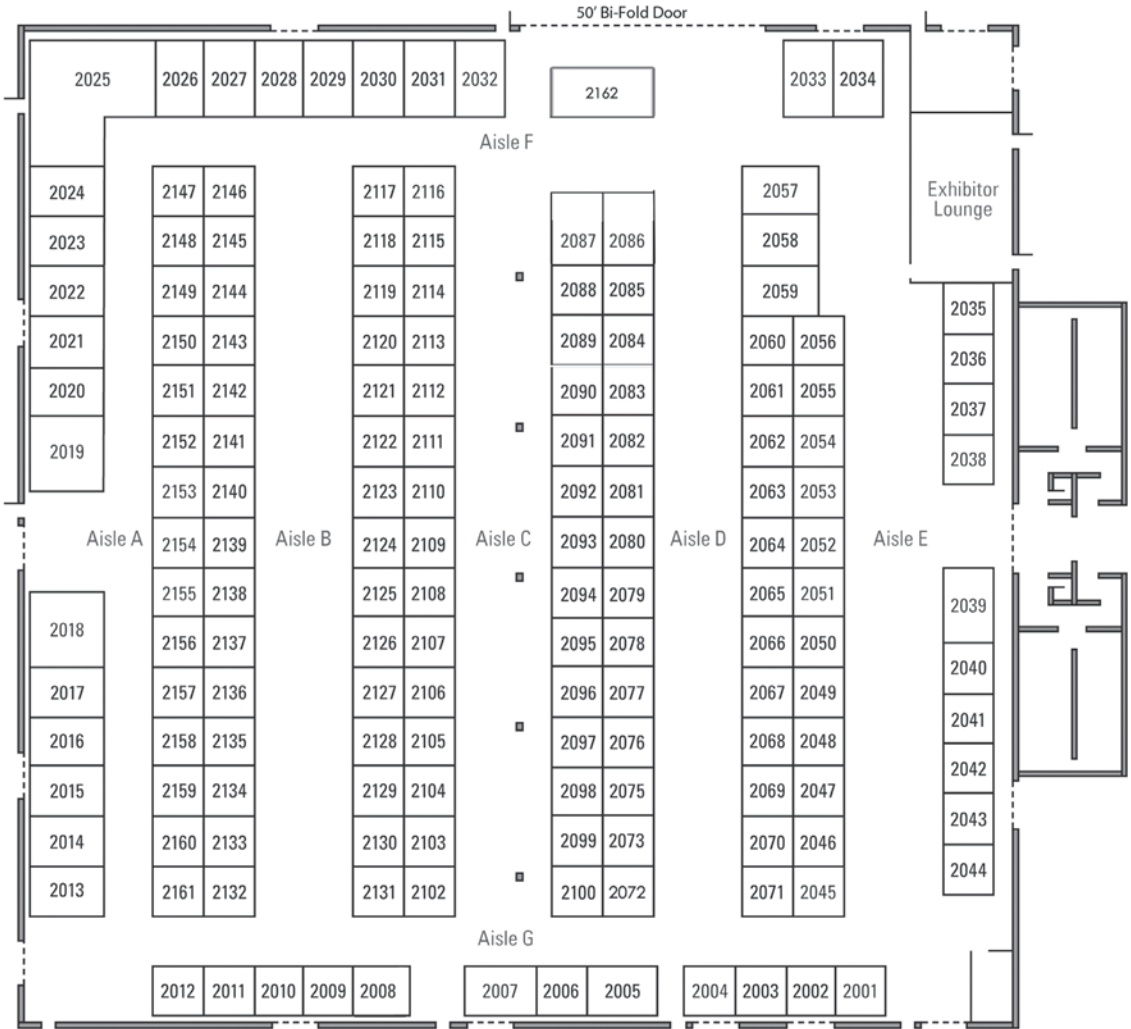



electroair
ELECTRONIC IGNITION SYSTEMS

SINGLE & DUAL ELECTRONIC IGNITION

REPLACEMENTS FOR CONVENTIONAL, TWO MAGNETO ENGINES AND BENDIX, SINGLE DRIVE DUAL MAGNETOS



Lycoming & Continental applications on over 500 aircraft models

Improved High Altitude Performance
10-15% Fuel Savings | Reduced Maintenance

FACTORY SUPPORT
248-674-3433

SALES:
281.728.8732

electroair
ELECTRONIC IGNITION SYSTEMS

electroair.net



EPIC AIRCRAFT EXHIBIT HANGAR C

Booths 3000-3176

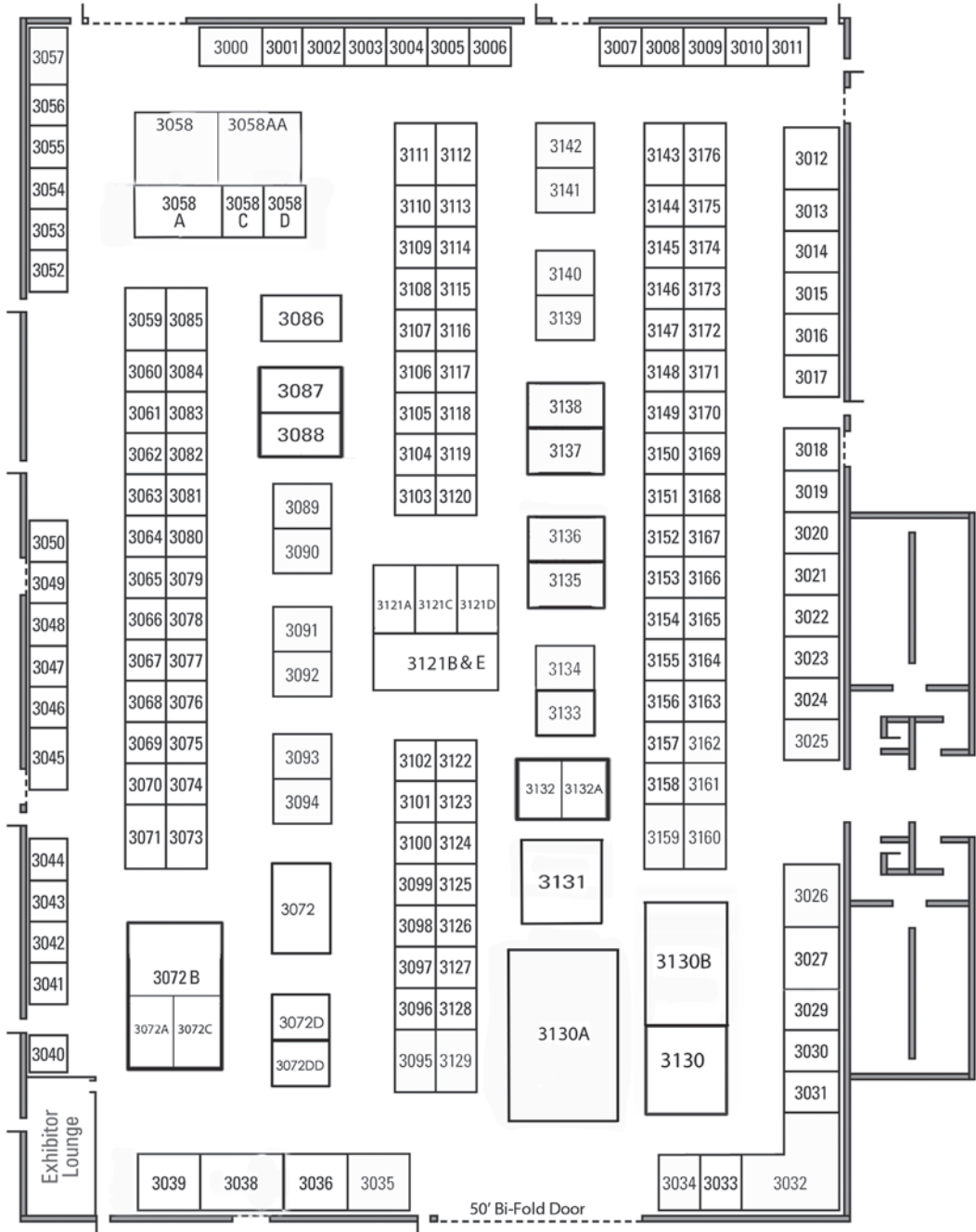



Procedure Trainer

Practice 11 different normal and emergency procedures in augmented reality for the Cessna 172.



The future
of pilot training
is here...
and **it's free!**

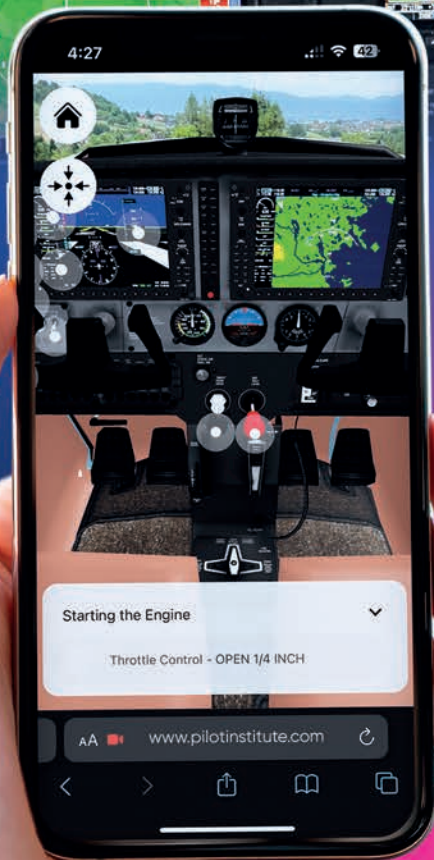

DELTAHAWK ENGINES EXHIBIT HANGAR D

Booths 4001-4114, IFP-1-IFP-16

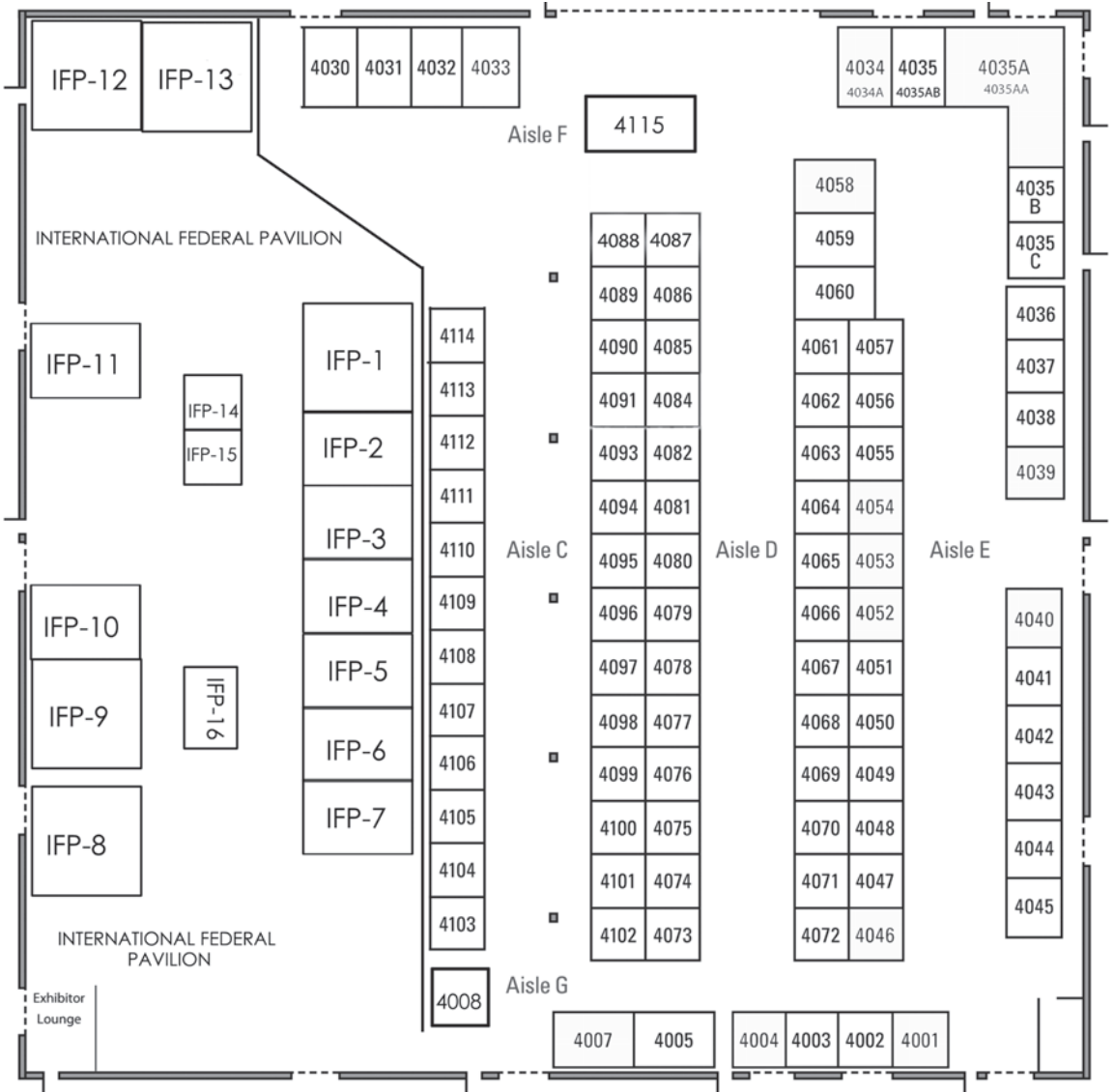

Working harder to keep you flying



At Tempest our greatest resource is our people. Their dedication keeps us committed to general aviation and why we are proud to call North Carolina home to our oil filter manufacturing.

Made in the USA



www.aeroaccessories.com





AirVenture Visitors Map Key

- | | | | | | |
|--|------------------------|--|--|--|----------------|
| | ADA Accessible Parking | | Changing/Nursing Station | | First Aid |
| | ATM | | Drinking Water | | Flush Toilets |
| | Basler Fuel Service | | Drinking Water/Cooling Station
<i>Sponsored by GE Aerospace</i> | | Food Locations |
| | Bike Parking | | Exhibit Spaces | | Grocery |
| | | | | | Ice Sales |

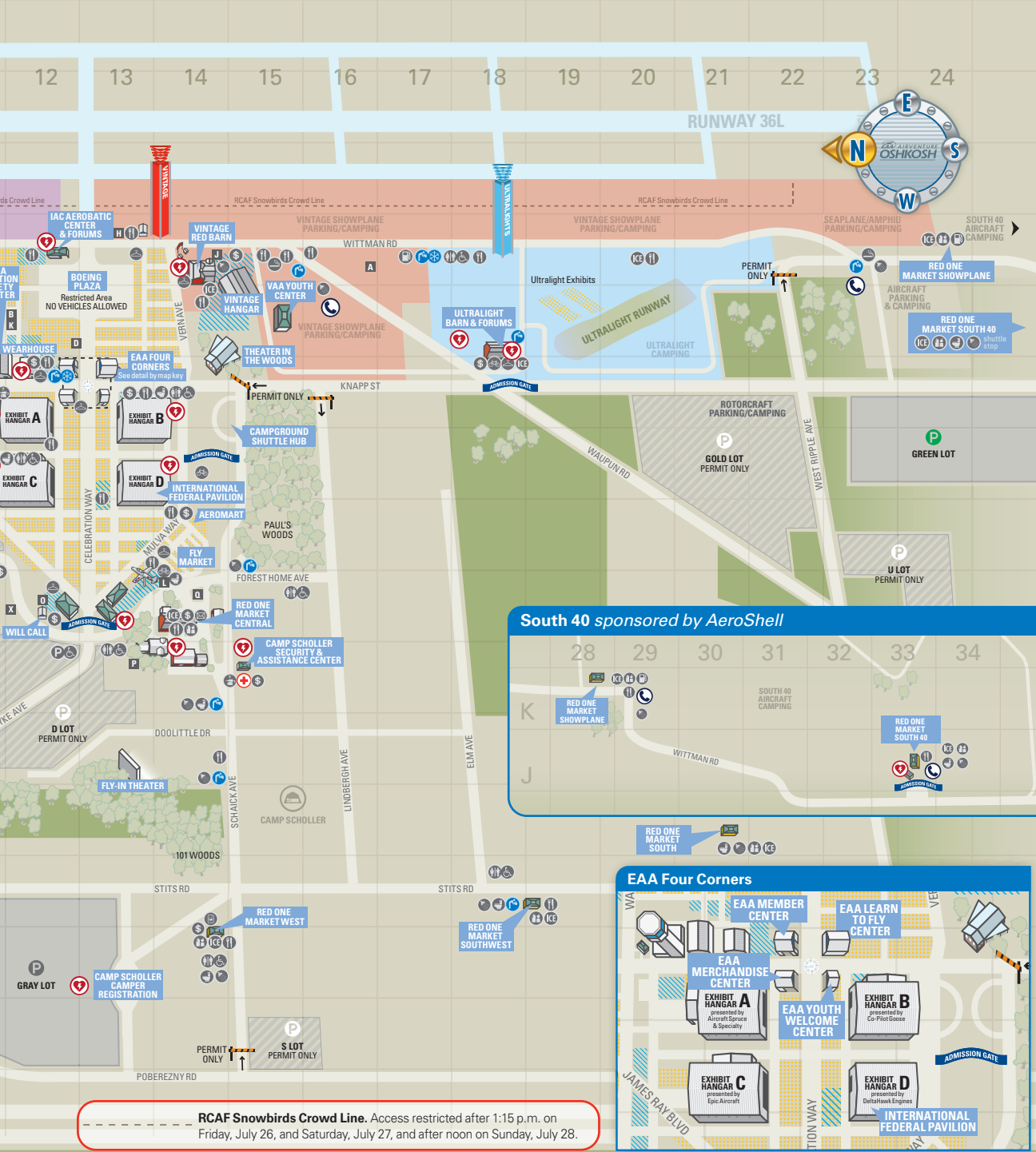

RCAF Snowbirds Crowd Line. Access restricted after 1:15 p.m. on Friday, July 26, and Saturday, July 27, and after noon on Sunday, July 28.

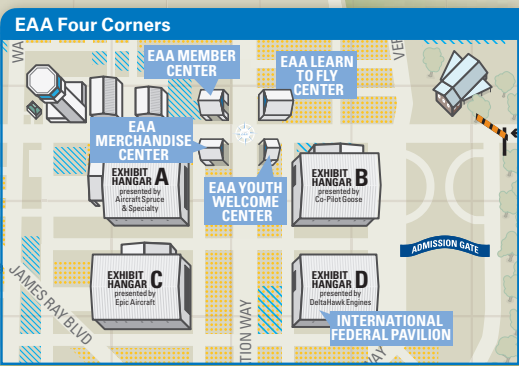
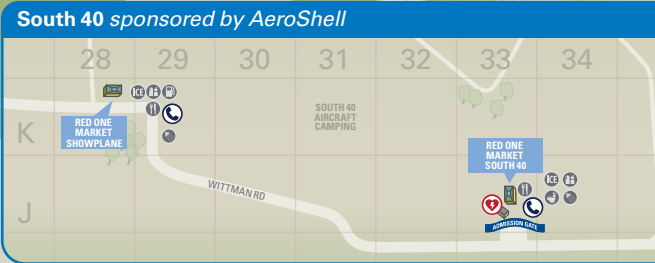

- Laundry Facility
- Shipping Services/Mailbox
- Lost and Found
- Showers
- Merchandise
- Smoking Area
- Shade Locations
- Wheelchair Accessible Restrooms

AED (Defibrillator) Locations

Emergency Tower Locations

General Parking (5 lots) Sponsored by Garmin®

Permit Only Parking (8 lots)

EAA AirVenture Special

goose

YOUR DIGITAL CO-PILOT

only NOW!
\$4.99
3 months
Premium

trusted by 10k+ pilots - flown 1.25 million NM in 13,000 hours already - **JOIN NOW!**

“Alexa for Pilots”

-Aviation Consumer



Download for
free now!



We help single pilots to get all information they need for a safe and convenient flight by providing the best voice assistant in aviation

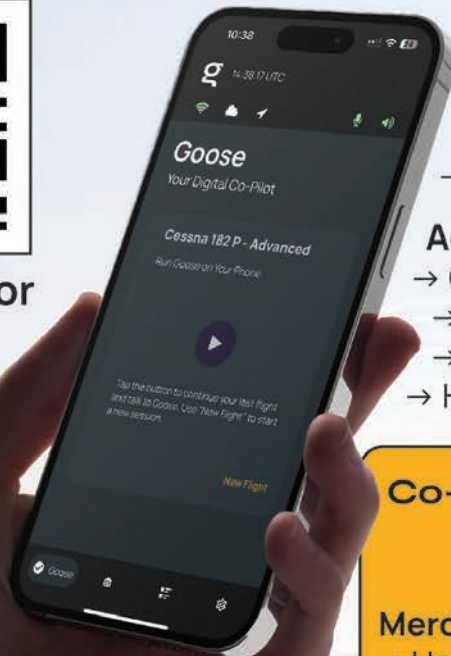

Included in Goose:

- Awarded and most advanced checklist editor
- Procedures from 500+ AC
- AFM & POH Builder

Access with your voice

- Checklists & Procedures
- Frequencies
- Navigation Briefings
- Hands-free EFB Control

Co-Pilot Goose Hangar B

@ booth #2162

Merch & FREE give-aways!

- Headset mic replacement foam
- Prop Cards ('Do Not Touch')
- Hats, Bags, shirts & more!

Be a Maverick. Fly With Goose!

www.aerosys.io
@Goose.TalkToMe

aerosys

SPONSORED BY



Cleveland
Wheels & Brakes



WHAT TO SEE AND DO

There is so much to see and do at EAA AirVenture Oshkosh 2024 — forums, workshops, air shows, movies, and more. Whether you are here for the day or for the whole week, use this schedule to get the most out of your visit.

NOTE: Check the *AirVenture Today* newspaper, the EAA Events app, or EAA.org/Schedule for schedule changes and updates.

All presentations from Saturday, July 20, to Sunday, July 28, are organized by day and time. Each listing provides the speaker(s), location, and AirVenture grounds map coordinates (see the AirVenture map on pages 70 and 71) to help you find your way.

TYPE OF EVENT KEY

Air Show	A	Flight Experience	FE	Movie	M
Church Services	CS	Forum	F	Radio Show	R
Clinic	C	Meet & Greet	MG	Special Event	SE
Demonstration	D			Workshop	W

DAILY EVENTS

Sponsored by **AIRCRAFT WHEEL & BRAKE BY KAMAN**

Cleveland
Wheels & Brakes

TIME	PRESENTATION	SPEAKER	LOCATION	MAP	TYPE
SATURDAY, JULY 20, 2024					
8:30 PM - 10:45 PM	Top Gun		Fly-In Theater Presented by Lycoming	E-13	M
SUNDAY, JULY 21, 2024					
8:30 AM - 9:00 AM	Nondenominational Service		Chapel and Compass Hill	E-8	CS
9:15 AM - 10:00 AM	Protestant Service		Theater in the Woods Supported by M&M'S	K-15	CS
9:30 AM - 10:00 AM	Nondenominational Service		Chapel and Compass Hill	E-8	CS
10:15 AM - 11:15 AM	Catholic Mass		Theater in the Woods Supported by M&M'S	K-15	CS
3:00 PM - 4:00 PM	10th Annual Volunteer Park Awards		Volunteer Park	G-14	SE
7:00 PM - 10:30 PM	An Evening With Champions		Theater in the Woods Supported by M&M'S	K-15	SE
8:30 PM - 10:45 PM	A Million Miles Away		Fly-In Theater Presented by Lycoming	E-13	M

DAILY EVENTS

Sponsored by  **AIRCRAFT**
WHEEL & BRAKE
BY KAMAN

Cleveland
Wheels & Brakes

TIME	PRESENTATION	SPEAKER	LOCATION	MAP	TYPE
MONDAY, JULY 22, 2024					
7:00 AM - 7:45 AM	Fellowship of the Wing		Chapel and Compass Hill	E-8	CS
7:00 AM - 8:00 AM	Yoga With Carrie		EAA WomenVenture Center	K-10	F
7:00 AM - 9:00 AM	Balloon Static Inflation		Fun Fly Zone	K-20	SE
7:00 AM - 9:00 AM	Powered Parachutes		Fun Fly Zone	K-20	SE
8:00 AM - 9:00 AM	G3X Touch Wiring & Data Buses	Garmin Aviation Team	Garmin Seminar Tent 1	K-13	F
8:00 AM - 9:00 AM	Pilot Training With GFC 500X	Garmin	Garmin Seminar Tent 2	K-13	F
8:00 AM - 9:00 AM	Coffee & Vintage Town Hall Meeting	Susan Dusenbury	Charles W. Harris Youth Aviation Center	L-15	F
8:00 AM - 12:00 PM	Metal Shaping Demonstration	Dave Wenglarz	Vintage Hangar	K-15	D
8:30 AM - 9:15 AM	ATC & You: Speaking With Confidence	NATCA	NATCA Booth	J-10	F
8:30 AM - 9:30 AM	Can I Run My Engine Lean of Peak?	Chuck Cook	Continental Aerospace Technologies	J-12	F
8:30 AM - 9:45 AM	The Evolution of Aviation Training	Christine Bohl	EAA WomenVenture Center	K-10	F
8:30 AM - 9:45 AM	Pioneering Electric Seaplane Flight	Erika Holtz	Forum Stage 1: WILCO	K-9	F
8:30 AM - 9:45 AM	Owner Inspections	Steven Boggess	Forum Stage 2: Aero Hose Shop	K-9	F
8:30 AM - 9:45 AM	LLCs and Illegal Charters	Scott Williams	Forum Stage 3: Superflite	K-9	F
8:30 AM - 9:45 AM	Advanced Flight Planning	Robert McGuire	Forum Stage 4: Pilotsmith	J-9	F
8:30 AM - 9:45 AM	Aviation Decompression Sickness	Dr. Daniel Johnson	Forum Stage 5: Scheme Designers	J-9	F
8:30 AM - 9:45 AM	Lycoming Troubleshooting	Tyler Harbach	Forum Stage 6: EnerSys	J-9	F
8:30 AM - 9:45 AM	The Skew-T Log-P Diagram Explained	Dr. Scott Dennstaedt	Forum Stage 7: ForeFlight	J-9	F
8:30 AM - 9:45 AM	All Flight Instruction for Everyone	Glenn Kowack	Forum Stage 8: GAMA	J-9	F
8:30 AM - 9:45 AM	uAvionix Upcoming Products	uAvionix	Forum Stage 9: SOFTIE PARACHUTES by Para-Phernalia Inc.	J-9	F
8:30 AM - 9:45 AM	Fabric Covering 101	EAA SportAir	Forum Stage 10: Poly Fiber Inc.	K-9	W
8:30 AM - 9:45 AM	Flying Like a Test Pilot	Jonathan "Gremlin" Aronoff	Forum Stage 11: DeltaHawk Engines	K-9	F
8:30 AM - 9:45 AM	Sheet Metal 101	EAA SportAir Sheet Metal	Sheet Metal Workshop Presented by Aircraft Spruce & Specialty	J-10	W
8:30 AM - 9:45 AM	Composite 101	EAA SportAir Composites	Workshop Classroom A	K-10	W
8:30 AM - 9:45 AM	Wood Construction 101	EAA SportAir Wood	Wood Workshop	K-10	W
8:30 AM - 9:45 AM	Intro to Oxy-Fuel Welding	Archie Frangoudis	Workshop Classroom B	K-10	F
8:30 AM - 9:45 AM	Gas Welding 101	EAA SportAir Gas Welding	Gas Welding Workshop	K-10	W
8:30 AM - 9:45 AM	Oil Analysis: All You Need to Know	Ryan Stark	Workshop Classroom C	K-10	F
8:30 AM - 9:45 AM	Plane & Simple: A Writer's Workshop	Cam Martin	EAA Museum - Vette Theater	B-8	F
8:30 AM - 9:45 AM	Adventures of a Private Pilot	Diane Ballweg	EAA Museum - Hilton Theater	B-8	F
8:30 AM - 9:45 AM	Bugatti Model 100P Racer	Robert Havens	EAA Museum - Skyscape Theater	B-8	F
8:30 AM - 9:45 AM	Build a Zenith Cruiser in a Garage	John DiMattei	Homebuilders Hangar Supported by Aircraft Spruce & Specialty	K-9	F
8:30 AM - 10:15 AM	FAA Accident Investigation Updates	Pat Hempen	FAA Aviation Safety Center, Flight Service Station	J-11	F
8:30 AM - 12:00 PM	TIG Welding 101	EAA SportAir TIG Welding	TIG Welding Workshop Presented by Lincoln Electric	K-10	W
8:30 AM - 2:30 PM	Homebuilders Workshop Acro/Sonex	Aeroplane Workshop Volunteers	Aeroplane Workshop	L-9	D
8:30 AM - 2:30 PM	Cozy Aircraft Build		Aeroplane Workshop	L-9	D
8:30 AM - 2:30 PM	Fabric Covering Demonstration		Aeroplane Workshop	L-9	D
8:30 AM - 2:30 PM	Player Special Restoration		Aeroplane Workshop	L-9	D
8:30 AM - 3:45 PM	Zenith Kit Assembly Demonstration		Aeroplane Workshop	L-9	D
9:00 AM - 9:30 AM	Youth Aviation Ribbon-Cutting	AC & Sue Hutson	Charles W. Harris Youth Aviation Center	L-15	F
9:00 AM - 9:30 AM	3D	Mark Kennison	Aeroplane Workshop	L-9	W
9:00 AM - 9:45 AM	Checkride Tips for Success	Jason Blair	AOPA Program Pavilion	L-11	F
9:00 AM - 9:45 AM	Rotax 503 Teardown and Assembly	Jeff Howell	Ultralight Workshop Tent	K-18	F
9:00 AM - 9:45 AM	Good Instructors Are Great Students	Elizabeth Vulgamore	NAFI Booth	J-14	F
9:00 AM - 10:00 AM	Intro to Rotax Aircraft Engines	Lauren Burton	Rotax Aircraft Engines Booth	J-12	F
9:00 AM - 10:00 AM	Design, Build, Fly: Airplane Sims	Embry-Riddle Aeronautical University	Embry-Riddle Booth 49	J-10	F
9:00 AM - 10:00 AM	Finding Answers in Garmin Documents	Garmin Aviation Team	Garmin Seminar Tent 1	K-13	F
9:00 AM - 10:00 AM	GTN/GTN Xi Training: Tips & Tricks	Garmin	Garmin Seminar Tent 2	K-13	F
9:00 AM - 10:00 AM	Plane Talk	Ryan Dembroski	Boeing Plaza	L-13	F
9:00 AM - 10:00 AM	Thundermouse	Caroline "Blaze" Jensen	EAA Wearhouse	J-12	MG
9:00 AM - 10:00 AM	Ercoupe Owners Club Forum	Syd Cohen	Vintage Hangar	K-15	F

BREAK THE ICE

WITH ICE SHIELD® DE-ICE BOOTS



VISIT BOOTH 3030

- AVAILABLE IN STANDARD & PRESSURE SENSITIVE ADHESION (PSA) APPLICATION
- AVAILABLE IN BLACK AND SILVER (DEPENDING ON PLATFORM APPLICATION)
- OEM AND FAA/PMA APPROVED
- BEST IN MARKET QUALITY
- NO HASSLE WARRANTY
- WORLDWIDE AUTHORIZED INSTALLATION CENTERS
- BOOT CARE KITS



1-800-767-6899

WWW.ICESHIELD.COM

INFO@ICESHIELD.COM

DAILY EVENTS

Sponsored by  **AIRCRAFT
WHEEL & BRAKE**
BY KAMAN

Cleveland
Wheels & Brakes

TIME	PRESENTATION	SPEAKER	LOCATION	MAP	TYPE
MONDAY, JULY 22, 2024					
9:00 AM - 10:15 AM	Reunion of Giants: Lancaster to UK		EAA Canada	K-12	F
9:00 AM - 11:00 AM	On the Grounds & Up	Jerry Burke	EAA Wearhouse	J-12	MG
9:00 AM - 11:30 AM	Ultralights and Lightplanes		Fun Fly Zone	K-20	SE
9:00 AM - 12:00 PM	Paul's Vintage Workshop	Jim Hamilton	Vintage Hangar	K-15	W
9:15 AM - 9:30 AM	GE Aerospace Careers Open House	Talent Acquisition - GE Aerospace	GE Aerospace	K-14	MG
9:30 AM - 10:15 AM	Anticipating Severe Weather	Richard Mamrosh	International Federal Pavilion	I-13	F
9:30 AM - 10:30 AM	Straighten Up & Fly Right	Greg Roark	Redbird Sim Lab	J-13	F
9:30 AM - 10:45 AM	ATC & You: SIDS/STARS	NATCA	NATCA Booth	J-10	F
9:30 AM - 11:30 AM	Lycoming Engine Valve Operation	Michael Damiani	Lycoming Engines Booth	J-12	D
10:00 AM - 10:30 AM	Hand Propping Demonstration	Dion Carr	Rose Plaza Interview Circle	L-14	D
10:00 AM - 10:30 AM	Catalyst Engine: Beechcraft Denali	Josh Hobson	GE Aerospace	K-14	F
10:00 AM - 10:30 AM	GNS-to-IFD in Experimental Aircraft	Tom Harper	Avidyne Booth 3130A	I-12	F
10:00 AM - 10:45 AM	Teaching the Impossible Turn	Mike Vaccaro	NAFI Booth	J-14	F
10:00 AM - 10:45 AM	How to Enter the World of Warbirds	Michael Ginter	AOPA Program Pavilion	L-11	F
10:00 AM - 10:45 AM	Rotax 503 Teardown and Assembly	Jeff Howell	Ultralight Workshop Tent	K-18	F
10:00 AM - 11:00 AM	Engine Leaning Made Simple	Bill Ross	Superior Air Parts Booth	I-13	F
10:00 AM - 11:00 AM	Continental's Guide to Reaching TBO	Tim Owen	Continental Aerospace Technologies	J-12	F
10:00 AM - 11:00 AM	Getting Started With Garmin Pilot	Garmin	Garmin Seminar Tent 2	K-13	F
10:00 AM - 11:00 AM	Flying With G3X Touch Training	Garmin Aviation Team	Garmin Seminar Tent 1	K-13	F
10:00 AM - 11:00 AM	Shuttle, Houston	Paul Dye	EAA Wearhouse	J-12	MG
10:00 AM - 11:00 AM	Plane Talk	Ryan Dembroski	Boeing Plaza	L-13	F
10:00 AM - 11:00 AM	Grease Basics and Functions	Piotr Gawecki	AeroShell Booth 446/457	L-11	F
10:00 AM - 11:00 AM	Dynon Systems for Experimentals	Dynon Staff	Dynon Tent	I-13	F
10:00 AM - 11:00 AM	GE Aerospace: CF34 Fan Maintenance	Jim Condon	GE Aerospace	K-14	F
10:00 AM - 11:00 AM	Aeronca Nation	Lt. Col. Craig MacVeigh	Vintage Hangar	K-15	F
10:00 AM - 11:15 AM	Stinson L-5 Sentinel	Steve Seal	Warbirds in Review	L-7	F
10:00 AM - 11:15 AM	Starting a New EAA Chapter	Serena Brouillette	EAA Blue Barn Featuring EAA Chapters, EAA Young Eagles, and EAA Eagle Flights	J-9	F
10:00 AM - 11:15 AM	Extend the Life of Your Propeller	Aaron "Opie" Perry	Hartzell Propeller 296-297	J-13	F
10:00 AM - 11:15 AM	Stop Dreaming, Start Flying	David Leiting	EAA Learn to Fly Center	J-13	F
10:00 AM - 11:15 AM	First Women Military Whirlybirds	Eileen Bjorkman	EAA WomenVenture Center	K-10	F
10:00 AM - 11:15 AM	Picking the Best Aircraft for You	Scott "Sky" Smith	Forum Stage 1: WILCO	K-9	F
10:00 AM - 11:15 AM	The Aileron Patent Story	Russell Klingaman	Forum Stage 2: Aero Hose Shop	K-9	F
10:00 AM - 11:15 AM	Achieving Best Brake Performance	Ben McNamara	Forum Stage 3: Superflite	K-9	F
10:00 AM - 11:15 AM	Caution: Helicopter Wake Turbulence	Ned Parks	Forum Stage 4: Pilotsmith	J-9	F
10:00 AM - 11:15 AM	Flying Without Arms	Jessica Cox	Forum Stage 5: Scheme Designers	J-9	F
10:00 AM - 11:15 AM	Flight Testing Basics	Gary Baker	Forum Stage 6: EnerSys	J-9	F
10:00 AM - 11:15 AM	EAGLE Unleaded Fuels Forum	EAA Govt Advocacy Team	Forum Stage 7: ForeFlight	J-9	F
10:00 AM - 11:15 AM	How to Really Design an Airplane	Barnaby Wainfan	Forum Stage 8: GAMA	J-9	F
10:00 AM - 11:15 AM	Zenith Aircraft Co. Updates	Sebastien Heintz	Forum Stage 9: SOFTIE PARACHUTES by Para-Phernalia Inc.	J-9	F
10:00 AM - 11:15 AM	The RV-12iS in Flight Schools	Aric Krause	Forum Stage 10: Poly Fiber Inc.	K-9	F
10:00 AM - 11:15 AM	Aircraft Ownership: The REAL Cost	Richard Wetherald	Forum Stage 11: DeltaHawk Engines	K-9	F
10:00 AM - 11:15 AM	Oratex6000 Used Correctly	Lars Gleitsmann	Workshop Classroom A	K-10	W
10:00 AM - 11:15 AM	Aircraft Hose	Chelsey Hickey	Workshop Classroom B	K-10	F
10:00 AM - 11:15 AM	Engine Mounts and Shimmy Dampers	Emily Mogel	Workshop Classroom C	K-10	F
10:00 AM - 11:15 AM	Forming Basics	Mark Kennison	Aeroplane Workshop	L-9	W
10:00 AM - 11:15 AM	Teachers: Integrate Aviation/STEM	Barbara Walters-Phillips	EAA Museum - Hilton Theater	B-8	F
10:00 AM - 11:15 AM	The Secrets of Orchard Place	John Mellberg	EAA Museum - Skyscape Theater	B-8	F
10:00 AM - 11:15 AM	Homebuilt Judging	EAA Homebuilt Awards	Homebuilders Hangar Supported by Aircraft Spruce & Specialty	K-9	F
10:00 AM - 11:15 AM	Homebuilts in Review		Homebuilts in Review	K-9	F
10:00 AM - 11:15 AM	Getting Started in Ultralights	Timm Bogenhagen	Ultralight Forums Tent	K-18	F
10:15 AM - 11:30 AM	Flying to and From Canada	Ian Brown	EAA Canada	K-12	F
10:15 AM - 12:00 PM	Cleared for Takeoff	James Groat	FAA Aviation Safety Center, Flight Service Station	J-11	F



Celebrating 25 Years manufacturing lightweight, energy efficient and cost-effective Radio and Transponder technology in Australia for Light Sports, General and Experimental aircraft.



Enhance your
Situational Awareness

Amplify your
Communication Capabilities

Confidently fly and
Navigate the skies

Introducing the new T3000

A completely modular, light-weight and compact avionics capability

NAV COMMS

Multi-channel high power comms.
Dual channel - 16 Watts

TRANSPONDER*

Mode S, ADSB In and Out

NAVIGATION SENSORS

Multiple user selected face options
available.



Multiple user selected face options
available for a complete avionics panel. (Examples)



90MIN BATTERY BACK-UP

 www.microair.aero



Come and see us at Booth 4001/4002
SECURE YOUR LAUNCH DISCOUNT



*Available late 2024/early 2025

DAILY EVENTS

Sponsored by  AIRCRAFT
WHEEL & BRAKE
BY KAMAN

Cleveland
Wheels & Brakes

TIME	PRESENTATION	SPEAKER	LOCATION	MAP	TYPE
MONDAY, JULY 22, 2024					
10:30 AM - 11:15 AM	Solving Conservation Problems	Garrett Wilkerson	International Federal Pavilion	I-13	F
10:30 AM - 11:30 AM	What Makes an Airplane Fly?	Greg Roark	Redbird Sim Lab	J-13	F
10:45 AM - 12:00 PM	Vintage in Review	Ray Johnson	Rose Plaza Interview Circle	L-14	F
11:00 AM - 11:30 AM	Day in the Life of an Airline Pilot	F/O Justin Dahan	ALPA Booth 329	K-14	FE
11:00 AM - 11:30 AM	Let Your Pilot Career Take Flight	Southwest Airlines	Southwest Airlines	I-10	F
11:00 AM - 11:45 AM	ATD for Flight Training	John DiMattei	NAFI Booth	J-14	F
11:00 AM - 11:45 AM	Trapped in the Hills: Complacency	Adam Rarey	AOPA Program Pavilion	L-11	F
11:00 AM - 12:00 PM	Cockpit Upgrades on a Budget	Garmin	Garmin Seminar Tent 2	K-13	F
11:00 AM - 12:00 PM	An In-Depth Look at GI 275	Garmin Aviation Team	Garmin Seminar Tent 1	K-13	F
11:00 AM - 12:00 PM	Plane Talk	Ryan Dembroski	Boeing Plaza	L-13	F
11:00 AM - 12:00 PM	Leading With Honor and More	Leon "Lee" Ellis	EAA Wearhouse	J-12	MG
11:00 AM - 12:00 PM	Turbine Oil Differences	Piotr Gawecki	AeroShell Booth 446/457	L-11	F
11:00 AM - 12:00 PM	American Navion Society Forum	Rusty Herrington	Vintage Hangar	K-15	F
11:00 AM - 12:15 PM	ATC & You: Make the Most of VFR	NATCA	NATCA Booth	J-10	F
11:00 AM - 12:45 PM	Women's Intro to Sheet Metal	Louise Hose	Sheet Metal Workshop Presented by Aircraft Spruce & Specialty	J-10	W
11:30 AM - 12:00 PM	MIDAS: Icing Detection Alert for Pi	Cole Rosentreter	EAA Canada	K-12	F
11:30 AM - 12:00 PM	Landing an Aviation Scholarship	F/O Camila Turrieta	ALPA Booth 329	K-14	FE
11:30 AM - 12:15 PM	WASP in Their Own Words	Lisa Taylor	EAA WomenVenture Center	K-10	F
11:30 AM - 12:15 PM	TFRs: How to Avoid an Intercept	Lt. Col. Trevor "Boat" Boswell	International Federal Pavilion	I-13	F
11:30 AM - 12:30 PM	Reaching Optimal Engine Performance	Chuck Cook	Continental Aerospace Technologies	J-12	F
11:30 AM - 12:30 PM	Stalls	Greg Roark	Redbird Sim Lab	J-13	F
11:30 AM - 12:30 PM	ADVANCEDPANEL Ecosystem Expansion	AFS Staff	Dynon Tent	I-13	F
11:30 AM - 12:45 PM	The Basics of Medical Certification	EAA Aeromedical Advisory Council	EAA Learn to Fly Center	J-13	F
11:30 AM - 12:45 PM	501(c)(3) Status and Your Chapter	Patricia Arthur, Esq.	EAA Blue Barn Featuring EAA Chapters, EAA Young Eagles, and EAA Eagle Flights	J-9	F
11:30 AM - 12:45 PM	Building Your Dream Airport	Gary Stevens	Forum Stage 1: WILCO	K-9	F
11:30 AM - 12:45 PM	Picking a Homebuilt Design	Budd Davison	Forum Stage 2: Aero Hose Shop	K-9	F
11:30 AM - 12:45 PM	KR Experimental Aircraft Forum	Robert Schmitt	Forum Stage 3: Superlite	K-9	F
11:30 AM - 12:45 PM	NASA X-59 Pilots: First Flight	Nils Larson	Forum Stage 4: Pilotsmith	J-9	F
11:30 AM - 12:45 PM	Navigating the Ramp Check	EAA Legal Advisory Council	Forum Stage 5: Scheme Designers	J-9	F
11:30 AM - 12:45 PM	IFR: Top 5 Mistakes	Gary Reeves	Forum Stage 6: EnerSys	J-9	F
11:30 AM - 12:45 PM	ForeFlight Fundamentals	ForeFlight	Forum Stage 7: ForeFlight	J-9	F
11:30 AM - 12:45 PM	Destroy Your Engine in One Minute	Mike Busch	Forum Stage 8: GAMA	J-9	F
11:30 AM - 12:45 PM	Vantage12 Upgrade for Cirrus	Tom Harper	Forum Stage 9: SOFTIE PARACHUTES by Para-Phernalia Inc.	J-9	F
11:30 AM - 12:45 PM	Designing & Building Sling Aircraft	Mike Blyth	Forum Stage 10: Poly Fiber Inc.	K-9	F
11:30 AM - 12:45 PM	How Drones & GA Work Together	Zipline	Forum Stage 11: DeltaHawk Engines	K-9	F
11:30 AM - 12:45 PM	Fiberglass for RV	Scott VanderVeen	Workshop Classroom A	K-10	W
11:30 AM - 12:45 PM	Never Rib Stitch or Pop Rivet Again	Siegfried Lanitz	Workshop Classroom B	K-10	F
11:30 AM - 12:45 PM	Pressure Carburetors: Then and Now	Cory Miller	Workshop Classroom C	K-10	F
11:30 AM - 12:45 PM	English Wheel	Mark Kennison	Aeroplane Workshop	L-9	W
11:30 AM - 12:45 PM	Sharing the Future of Aviation	Mathew Fernandez	EAA Museum - Vette Theater	B-8	F
11:30 AM - 12:45 PM	Weather or Not to Fly	Jenna Williamson	EAA Museum - Hilton Theater	B-8	F
11:30 AM - 12:45 PM	Rise & Fall of an American Spy	Gary Cox	EAA Museum - Skyscape Theater	B-8	M
11:30 AM - 12:45 PM	Prebuys on Amateur-Built Aircraft	Vic Syracuse	Homebuilders Hangar Supported by Aircraft Spruce & Specialty	K-9	F
11:30 AM - 12:45 PM	What Is Powered Paragliding?	Mike Robinson	Ultralight Forums Tent	K-18	F
11:30 AM - 2:00 PM	Homebuilt Rotorcraft		Fun Fly Zone	K-20	SE
12:00 PM - 12:30 PM	Avidyne IFD With iPad/ForeFlight	Randall Edwards	Avidyne Booth 3130A	I-12	F
12:00 PM - 12:30 PM	Pathways to the Airlines	F/O Mark Lockwood	ALPA Booth 329	K-14	FE
12:00 PM - 12:45 PM	SMS for CFIs	Darin Laby	NAFI Booth	J-14	F
12:00 PM - 12:45 PM	Behind the Scenes of AOPA Media	David Tulis	AOPA Program Pavilion	L-11	F
12:00 PM - 1:00 PM	Garmin Engine Monitor Solutions	Garmin	Garmin Seminar Tent 2	K-13	F
12:00 PM - 1:00 PM	GNS Transition: Find Your Next GPS	Garmin Aviation Team	Garmin Seminar Tent 1	K-13	F



AOS368K
Air RO Sander

The perfect tools for
detailing, scratch repair,
and small parts finishing



FIND YOUR DEALER
🇺🇸 888-447-3926 🇨🇦 604-534-3688
www.grexusa.com

EAA AIRVENTURE
OSHKOSH
BOOTH# **2118**
SEE IT. TRY IT.



MF.TS
Micro Spray Gun



GREX
USA®

DAILY EVENTS

Sponsored by  **AIRCRAFT
WHEEL & BRAKE**
BY KAMAN

Cleveland
Wheels & Brakes

TIME	PRESENTATION	SPEAKER	LOCATION	MAP	TYPE
MONDAY, JULY 22, 2024					
12:00 PM - 1:00 PM	Plane Talk	Ryan Dembroski	Boeing Plaza	L-13	F
12:00 PM - 1:00 PM	True North	Darren Pleasance	EAA Wearhouse	J-12	MG
12:00 PM - 1:00 PM	Select the Best Piston Engine Oil	Piotr Gawecki	AeroShell Booth 446/457	L-11	F
12:00 PM - 2:00 PM	Engine Failure & Return to Airport	Dr. George Bolon	FAA Aviation Safety Center, Flight Service Station	J-11	F
12:00 PM - 5:00 PM	Type Clubs	Charlie Waterhouse	Vintage Hangar	K-15	F
12:30 PM - 1:00 PM	Military Vets to Airline Jets	Air Line Pilots Association	ALPA Booth 329	K-14	FE
12:30 PM - 1:15 PM	SARSAT Saves & Stats	Allan Knox	International Federal Pavilion	I-13	F
12:30 PM - 1:45 PM	ATC & You: Real-World Lessons Ch 1	NATCA	NATCA Booth	J-10	F
12:45 PM - 2:00 PM	Barriers for Women Who Fly	Sharon Cheung	EAA Canada	K-12	W
1:00 PM - 1:30 PM	Vantage12 Upgrade for Cirrus	Tom Harper	Avidyne Booth 3130A	I-12	F
1:00 PM - 1:30 PM	Let Your Pilot Career Take Flight	Southwest Airlines	Southwest Airlines	I-10	F
1:00 PM - 1:45 PM	Start a Flight School	Tim Poole	NAFI Booth	J-14	F
1:00 PM - 1:45 PM	Sporty's: iPad as Digital Co-Pilot	Bret Koebbe	AOPA Program Pavilion	L-11	F
1:00 PM - 2:00 PM	How to Plan and Shop for Avionics	Garmin	Garmin Seminar Tent 2	K-13	F
1:00 PM - 2:00 PM	Your Next Autopilot: GFC 500/600	Garmin Aviation Team	Garmin Seminar Tent 1	K-13	F
1:00 PM - 2:00 PM	The Airline Transition Manual	Andrew Ross	EAA Wearhouse	J-12	MG
1:00 PM - 2:00 PM	Plane Talk	Ryan Dembroski	Boeing Plaza	L-13	F
1:00 PM - 2:00 PM	Dynon Certified for TC Aircraft	Dynon Staff	Dynon Tent	I-13	F
1:00 PM - 2:00 PM	GE Aerospace: CF34 Fan Maintenance	Jim Condon	GE Aerospace	K-14	F
1:00 PM - 2:00 PM	Design, Build, Fly: Airplane Sims	Embry-Riddle Aeronautical University	Embry-Riddle Booth 49	J-10	F
1:00 PM - 2:15 PM	Home Flight Simulators 101	Chris McGonegle	EAA Learn to Fly Center	J-13	F
1:00 PM - 2:15 PM	Women of the Wisconsin Air Guard	Melinda "Lindi" Ilich	EAA WomenVenture Center	K-10	F
1:00 PM - 2:15 PM	Meet and Greet With Mike Goulian	Michael Goulian	Hartzell Propeller 296-297	J-13	MG
1:00 PM - 2:15 PM	Highly Successful EAA Chapters	Chris Gauger	EAA Blue Barn Featuring EAA Chapters, EAA Young Eagles, and EAA Eagle Flights	J-9	F
1:00 PM - 2:15 PM	Cessna L-19 Bird Dog	Gerry Asher	Warbirds in Review	L-7	F
1:00 PM - 2:15 PM	Flying to and Around Alaska	Anthony (Tony) Turinsky	Forum Stage 1: WILCO	K-9	F
1:00 PM - 2:15 PM	Al's Transformation of Flight	Yemaya Bordain	Forum Stage 2: Aero Hose Shop	K-9	F
1:00 PM - 2:15 PM	Defending the Skies: F-16 Alert Ops	Collin Coatney	Forum Stage 3: Superlite	K-9	FE
1:00 PM - 2:15 PM	Dispatch 101	Gregg Dubin	Forum Stage 4: Pilotsmith	J-9	F
1:00 PM - 2:15 PM	Single-Engine Solo Circumnavigation	Adele Basturk	Forum Stage 5: Scheme Designers	J-9	F
1:00 PM - 2:15 PM	Six Big Mistakes	Mike Busch	Forum Stage 6: EnerSys	J-9	F
1:00 PM - 2:15 PM	ForeFlight Power Users	ForeFlight	Forum Stage 7: ForeFlight	J-9	F
1:00 PM - 2:15 PM	Their GPS Could Kill You	Jeremy Bennington	Forum Stage 8: GAMA	J-9	F
1:00 PM - 2:15 PM	So You Want to Fly Helicopters	Philip Polstra	Forum Stage 9: SOFTIE PARACHUTES by Para-Phernalia Inc.	J-9	F
1:00 PM - 2:15 PM	Fabric Covering 101	EAA SportAir	Forum Stage 10: Poly Fiber Inc.	K-9	W
1:00 PM - 2:15 PM	Flying Beech Airplanes	American Bonanza Society	Forum Stage 11: DeltaHawk Engines	K-9	F
1:00 PM - 2:15 PM	Sheet Metal 101	EAA SportAir Sheet Metal	Sheet Metal Workshop Presented by Aircraft Spruce & Specialty	J-10	W
1:00 PM - 2:15 PM	Composite 101	EAA SportAir Composites	Workshop Classroom A	K-10	W
1:00 PM - 2:15 PM	Wood Construction 101	EAA SportAir Wood	Wood Workshop	K-10	W
1:00 PM - 2:15 PM	Dynamic Propeller Balancing	Steve Sennett	Workshop Classroom B	K-10	F
1:00 PM - 2:15 PM	Gas Welding 101	EAA SportAir Gas Welding	Gas Welding Workshop	K-10	W
1:00 PM - 2:15 PM	Homebuilt Project Management	William Judge	Workshop Classroom C	K-10	F
1:00 PM - 2:15 PM	Power Hammer	Mark Kennison	Aeroplane Workshop	L-9	W
1:00 PM - 2:15 PM	Letters From a Soviet Prison	Gary Powers Jr.	EAA Museum - Vette Theater	B-8	F
1:00 PM - 2:15 PM	Behind My Wings	BJ Elliott Prior	EAA Museum - Hilton Theater	B-8	F
1:00 PM - 2:15 PM	Why I Fly	Adam White	EAA Museum - Skyscape Theater	B-8	F
1:00 PM - 2:15 PM	Cross-Country: Beyond the Regs	Philip Mandel	Homebuilders Hangar Supported by Aircraft Spruce & Specialty	K-9	F
1:00 PM - 2:15 PM	Homebuilts in Review		Homebuilts in Review	K-9	F
1:00 PM - 2:15 PM	Intro to Powered Paragliding	Jonathan Eisele	Ultralight Forums Tent	K-18	F
1:00 PM - 2:30 PM	Vintage Children's Workshop	AC & Sue Hutson	Charles W. Harris Youth Aviation Center	L-15	W
1:00 PM - 3:00 PM	Reassembly of a Lycoming Engine	Michael Damiani	Lycoming Engines Booth	J-12	D

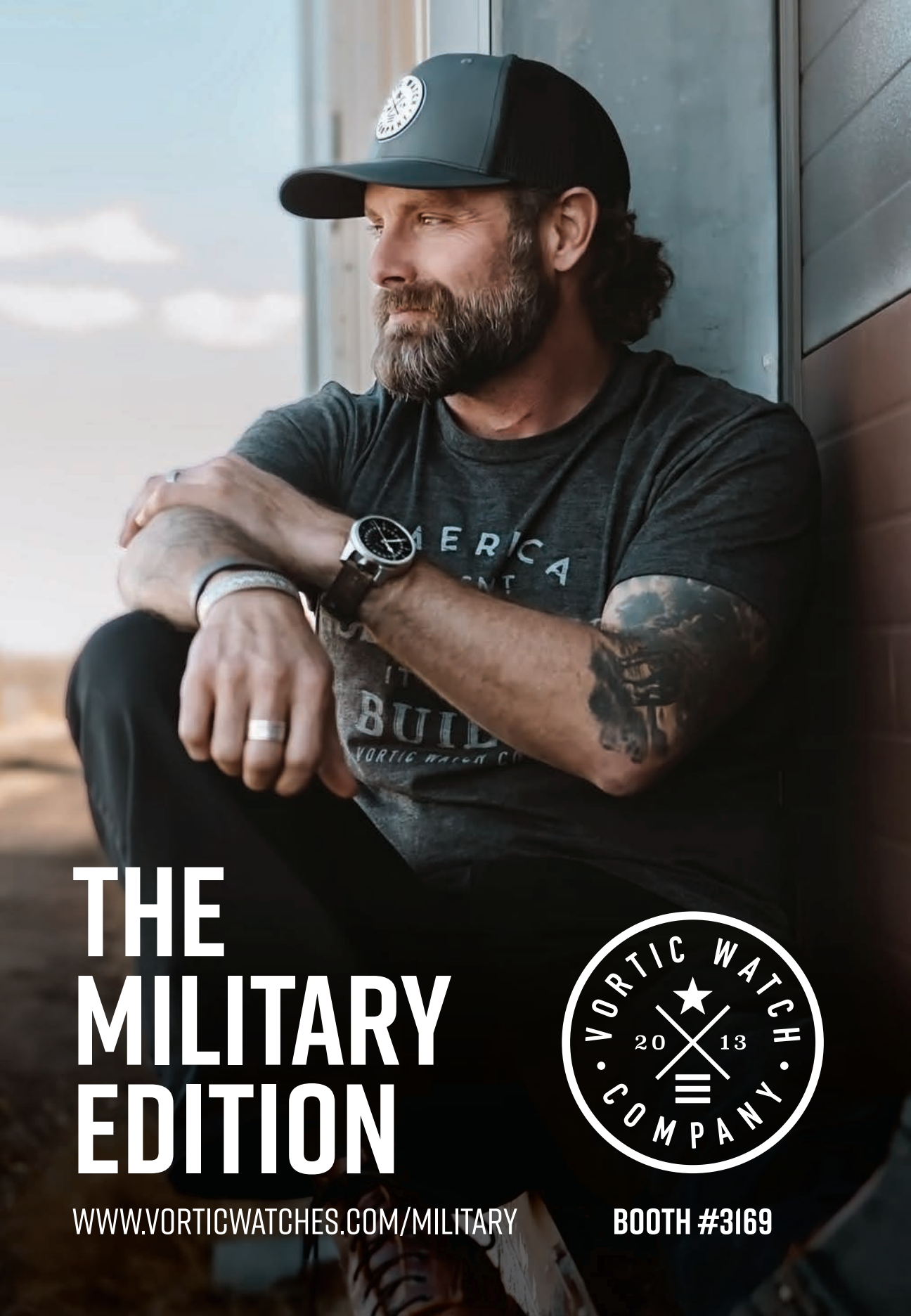

THE MILITARY EDITION

WWW.VORTICWATCHES.COM/MILITARY



BOOTH #3169

DAILY EVENTS

Sponsored by  AIRCRAFT
WHEEL & BRAKE
BY KAMAN

Cleveland
Wheels & Brakes

TIME	PRESENTATION	SPEAKER	LOCATION	MAP	TYPE
MONDAY, JULY 22, 2024					
1:00 PM - 4:00 PM	TIG Welding 101	EAA SportAir TIG Welding	TIG Welding Workshop Presented by Lincoln Electric	K-10	W
1:15 PM - 2:00 PM	Empowering Pilots With Data	Johnathan Morrell	GE Aerospace	K-14	F
1:30 PM - 2:15 PM	Wright-Patterson AFB & History	Steve Byington	International Federal Pavilion	I-13	F
1:30 PM - 2:30 PM	Night Flight	Larry Bothe	EAA Seaplane Base Presented by Wipaire	Seaplane Base	F
2:00 PM - 2:30 PM	Avidyne IFD With Portable Devices	Randall Edwards	Avidyne Booth 3130A	I-12	F
2:00 PM - 2:30 PM	Meet the Barany Chair	Dustin Kurath	NAFI Booth	J-14	F
2:00 PM - 2:45 PM	5 Things About Datalink Weather	Dr. Scott Dennstaedt	AOPA Program Pavilion	L-11	F
2:00 PM - 3:00 PM	Wow, It's Windy	Greg Roark	Redbird Sim Lab	J-13	F
2:00 PM - 3:00 PM	Building Your Experimental Panel	Garmin	Garmin Seminar Tent 2	K-13	F
2:00 PM - 3:00 PM	Choosing a Garmin PFD/MFD	Garmin Aviation Team	Garmin Seminar Tent 1	K-13	F
2:00 PM - 3:00 PM	Tailspin	John Armbruster	EAA Wearhouse	J-12	MG
2:00 PM - 3:15 PM	Canadian Airspace 101	Clark Morawetz	EAA Canada	K-12	F
2:00 PM - 4:00 PM	Improve Your Communication With ATC	Heather McNevin	FAA Aviation Safety Center, Flight Service Station	J-11	F
2:15 PM - 6:00 PM	Monday Air Show	EAA	Air Show	M-13	A
2:30 PM - 3:15 PM	Auto Ground Collision Avoidance	To Be Announced	International Federal Pavilion	I-13	F
2:30 PM - 3:45 PM	Barriers to the Flight Deck	Jenny Beatty	EAA WomenVenture Center	K-10	F
2:30 PM - 3:45 PM	AOA and Energy Maneuverability	Mike Vaccaro	Forum Stage 1: WILCO	K-9	F
2:30 PM - 3:45 PM	Still Married, Friends & Flying	Jack Beck	Forum Stage 2: Aero Hose Shop	K-9	F
2:30 PM - 3:45 PM	After the Crash	Andrew Graham	Forum Stage 3: Superflite	K-9	F
2:30 PM - 3:45 PM	The Mighty M-14P Russian Radial	Jill Gernetzke	Forum Stage 4: Pilotsmith	J-9	F
2:30 PM - 3:45 PM	Buy & Sell the World's Best	Chris Eichman	Forum Stage 5: Scheme Designers	J-9	F
2:30 PM - 3:45 PM	Aviation and Auto Oils: Differences	Steven Strollo	Forum Stage 6: EnerSys	J-9	F
2:30 PM - 3:45 PM	The Difference of Jeppesen Charts	Jeff Williams	Forum Stage 7: ForeFlight	J-9	F
2:30 PM - 3:45 PM	YouTube Meet and Greet	Daniel Millican	Forum Stage 8: GAMA	J-9	MG
2:30 PM - 3:45 PM	Tailwheel Flying: How to Start	Adriana Barragan Iberri	Forum Stage 9: SOFTIE PARACHUTES by Para-Phernalia Inc.	J-9	F
2:30 PM - 3:45 PM	Fly Yourself to the Caribbean	Rick Gardner	Forum Stage 10: Poly Fiber Inc.	K-9	F
2:30 PM - 3:45 PM	NASA on Hybrid Electric Airlines	Kate McMurtry	Forum Stage 11: DeltaHawk Engines	K-9	F
2:30 PM - 3:45 PM	Maintaining Your Grumman Aircraft	John Sjaardema	Workshop Classroom A	K-10	F
2:30 PM - 3:45 PM	Cylinder Borescope Inspection	David Pasquale	Workshop Classroom B	K-10	F
2:30 PM - 3:45 PM	Gas Welding Aluminum	EAA SportAir Gas Welding	Gas Welding Workshop	K-10	W
2:30 PM - 3:45 PM	How To Run a Flying Club	Ken VeArd	Workshop Classroom C	K-10	F
2:30 PM - 3:45 PM	Advanced Forming	Mark Kennison	Aeroplane Workshop	L-9	W
2:30 PM - 3:45 PM	B-17: The Final Mission	Chris Henry	EAA Museum - Vette Theater	B-8	F
2:30 PM - 3:45 PM	Flying Early Aeroplanes	Kip Lankenau	EAA Museum - Hilton Theater	B-8	F
2:30 PM - 3:45 PM	Ramblings of a Bomber Pilot	Frank Allen	EAA Museum - Skyscape Theater	B-8	M
2:30 PM - 3:45 PM	Flight Testing 101	Paul Dye	Homebuilders Hangar Supported by Aircraft Spruce & Specialty	K-9	F
2:30 PM - 3:45 PM	Sailcloth Installation and Care	Malcom Brubaker	Ultralight Forums Tent	K-18	F
3:00 PM - 3:45 PM	Caution: Helicopter Wake Turbulence	Ned Parks	AOPA Program Pavilion	L-11	F
3:00 PM - 4:00 PM	Halfway Around the World in 40 Days	Kathrin Kaiser	EAA Wearhouse	J-12	MG
3:15 PM - 4:00 PM	Royal Canadian Air Force History	Jim Bell	EAA Canada	K-12	F
3:30 PM - 4:15 PM	Flying to the Bahamas	To Be Announced	International Federal Pavilion	I-13	F
4:00 PM - 4:45 PM	Flying Over the Washington Monument	Bruno Brasileiro	AOPA Program Pavilion	L-11	F
4:00 PM - 5:00 PM	Miss Blue	Pam Ward	EAA Wearhouse	J-12	MG
4:00 PM - 5:15 PM	How to Defend Your Airport	Brad Walker	Forum Stage 1: WILCO	K-9	F
4:00 PM - 5:15 PM	Flying to Safety: Collapse Survival	Drew Miller	Forum Stage 2: Aero Hose Shop	K-9	F
4:00 PM - 5:15 PM	The Wonderful Warthog, Part 1	Michael Hare	Forum Stage 7: ForeFlight	J-9	F
4:00 PM - 5:15 PM	Preventive Maintenance	Kenneth MacLean	Workshop Classroom A	K-10	F
4:00 PM - 5:15 PM	21st Century Aircraft Detailing	Mehrdad Zarifkar	Workshop Classroom C	K-10	F
4:00 PM - 6:00 PM	Reducing Risk From Common Dangers	Victoria Lehman	FAA Aviation Safety Center, Flight Service Station	J-11	F
5:00 PM - 6:00 PM	The B-25 in the Backyard	Wally Soplata	EAA Wearhouse	J-12	MG
5:00 PM - 7:00 PM	NAFI Special Welcome Event	Gary Reeves	NAFI Booth	J-14	F

Test-fly this ad.

FOLD HERE

Fold this page and put it in front of your six-pack panel to see the difference real glass can make.



*Actual display size.

- GPS-aided AHRS • Standard synthetic vision • Audio panel interface • Built-in GPS steering
- Simple and affordable installation • Integrates with most legacy autopilots

Visit us at booth #2145-2148 in Hangar B for a limited time promo on all of our displays.



DAILY EVENTS

Sponsored by  AIRCRAFT
WHEEL & BRAKE
BY KAMAN

Cleveland
Wheels & Brakes

TIME	PRESENTATION	SPEAKER	LOCATION	MAP	TYPE
MONDAY, JULY 22, 2024					
6:00 PM - 7:00 PM	AirVenture Cup Awards	AirVenture Cup	Forum Stage 5: Scheme Designers	J-9	SE
6:30 PM - 7:30 PM	Ultralights and Lightplanes		Fun Fly Zone	K-20	SE
7:00 PM - 10:30 PM	The Universe and Everything Else	Burt Rutan	Theater in the Woods Supported by M&M'S	K-15	SE
7:30 PM - 8:00 PM	Powered Parachutes		Fun Fly Zone	K-20	SE
8:00 PM - 9:45 PM	Twilight Flight Fest		Fun Fly Zone	K-20	SE
8:30 PM - 10:45 PM	Fighter Squadron		Fly-In Theater Presented by Lycoming	E-13	M
8:30 PM - 9:30 PM	Balloon Glow		Fun Fly Zone	K-20	SE
TUESDAY, JULY 23, 2024					
7:00 AM - 7:45 AM	Fellowship of the Wing		Chapel and Compass Hill	E-8	CS
7:00 AM - 9:00 AM	Powered Parachutes		Fun Fly Zone	K-20	SE
7:00 AM - 9:00 AM	Balloon Static Inflation		Fun Fly Zone	K-20	SE
8:00 AM - 8:45 AM	Checkrides: By the Numbers	Andrew Dow	NAFI Booth	J-14	F
8:00 AM - 9:00 AM	Reducing Engine Operational Cost	Bill Ross	Superior Air Parts Booth	I-13	F
8:00 AM - 9:00 AM	Pilot Training With GFC 500X	Garmin	Garmin Seminar Tent 2	K-13	F
8:00 AM - 9:00 AM	Configuring G3X Touch	Garmin Aviation Team	Garmin Seminar Tent 1	K-13	F
8:00 AM - 9:00 AM	Hatz Biplane Association Forum	Jeffrey Orear	Vintage Hangar	K-15	F
8:00 AM - 9:15 AM	ATC & You: Misleading Airports	NATCA	NATCA Booth	J-10	F
8:00 AM - 12:00 PM	Metal Shaping Demonstration	Dave Wenglarz	Vintage Hangar	K-15	D
8:30 AM - 9:30 AM	Can I Run My Engine Lean of Peak?	Chuck Cook	Continental Aerospace Technologies	J-12	F
8:30 AM - 9:45 AM	EAA Programs Available for Chapters	John Egan	EAA Blue Barn Featuring EAA Chapters, EAA Young Eagles, and EAA Eagle Flights	J-9	F
8:30 AM - 9:45 AM	Inspiring the Next Generation	Nicole Ellis	EAA WomenVenture Center	K-10	F
8:30 AM - 9:45 AM	Quality Flight Training	Loren French	EAA Learn to Fly Center	J-13	F
8:30 AM - 9:45 AM	Innovating AAM With AFWERX	Hank Griffiths	Forum Stage 1: WILCO	K-9	F
8:30 AM - 9:45 AM	CAP's Aviation Programs	Susan Mallett	Forum Stage 2: Aero Hose Shop	K-9	F
8:30 AM - 9:45 AM	Fatigue and Burnout in Training	Nicoletta Fala	Forum Stage 3: Superflite	K-9	F
8:30 AM - 9:45 AM	Build a 60-Year Flying Club	George Scheer	Forum Stage 4: Pilotsmith	J-9	F
8:30 AM - 9:45 AM	Buying Your First Airplane	David Fill	Forum Stage 5: Scheme Designers	J-9	F
8:30 AM - 9:45 AM	Hydroplane Hydrogen-Powered AI	Anita Sengupta	Forum Stage 6: EnerSys	J-9	F
8:30 AM - 9:45 AM	What's Happening at Van's Aircraft	Van's Aircraft	Forum Stage 7: ForeFlight	J-9	F
8:30 AM - 9:45 AM	Airparks: Live the Dream	Erik McCormick	Forum Stage 8: GAMA	J-9	F
8:30 AM - 9:45 AM	AAM for Good and NASA's Impact	Jonas Jonsson	Forum Stage 9: SOFTIE PARACHUTES by Para-Phernalia Inc.	J-9	F
8:30 AM - 9:45 AM	Fabric Covering 101	EAA SportAir	Forum Stage 10: Poly Fiber Inc.	K-9	W
8:30 AM - 9:45 AM	Flying to the Bahamas and Caribbean	Jim Parker	Forum Stage 11: DeltaHawk Engines	K-9	F
8:30 AM - 9:45 AM	Sheet Metal 101	EAA SportAir Sheet Metal	Sheet Metal Workshop Presented by Aircraft Spruce & Specialty	J-10	W
8:30 AM - 9:45 AM	Composite 101	EAA SportAir Composites	Workshop Classroom A	K-10	W
8:30 AM - 9:45 AM	Wood Construction 101	EAA SportAir Wood	Wood Workshop	K-10	W
8:30 AM - 9:45 AM	Design and Build Wind Tunnels	Dr. David Ullman	Workshop Classroom B	K-10	F
8:30 AM - 9:45 AM	Gas Welding 101	EAA SportAir Gas Welding	Gas Welding Workshop	K-10	W
8:30 AM - 9:45 AM	Aircraft Tire Care and Maintenance	Mary Beth Widak	Workshop Classroom C	K-10	F
8:30 AM - 9:45 AM	Choosing a First Aerobatic Aircraft	Budd Davison	International Aerobatic Club (IAC) Aerobatics Center	L-12	F
8:30 AM - 9:45 AM	Angel Flight: Giving Back	Richard Wetherald	EAA Museum - Vette Theater	B-8	F
8:30 AM - 9:45 AM	Amelia, the Aircraft AGI	Aditya Mohan	EAA Museum - Hilton Theater	B-8	F
8:30 AM - 9:45 AM	The Girls From Sweetwater	Lisa Taylor	EAA Museum - Skyscape Theater	B-8	M
8:30 AM - 9:45 AM	Europa Aircraft Forum	Jim Butcher	Homebuilders Hangar Supported by Aircraft Spruce & Specialty	K-9	F
8:30 AM - 10:15 AM	Obtain a Compliant Wx Briefing	Dr. Terry Lankford	FAA Aviation Safety Center, Flight Service Station	J-11	F
8:30 AM - 12:00 PM	Gas Metal Arc Welding (MIG Welding)	EAA SportAir TIG Welding	TIG Welding Workshop Presented by Lincoln Electric	K-10	W
8:30 AM - 2:30 PM	Player Special Restoration		Aeroplane Workshop	L-9	D
8:30 AM - 2:30 PM	Fabric Covering Demonstration		Aeroplane Workshop	L-9	D
8:30 AM - 2:30 PM	Cozy Aircraft Build		Aeroplane Workshop	L-9	D
8:30 AM - 2:30 PM	Homebuilders Workshop Acro/Sonex	Aeroplane Workshop Volunteers	Aeroplane Workshop	L-9	D
8:30 AM - 3:45 PM	Zenith Kit Assembly Demonstration		Aeroplane Workshop	L-9	D
9:00 AM - 9:30 AM	3D	Mark Kennison	Aeroplane Workshop	L-9	W
9:00 AM - 9:45 AM	What Is New in ForeFlight	Ryan McBride	AOPA Program Pavilion	L-11	F



AeroShell



Let your confidence soar

Visit AeroShell at booths 446 & 457

Event Highlights

- The world's best-selling piston engine oil at special show prices
- See an aircraft and engine on display
- Technical forums, AeroShell merchandise and more!



Scan here for
directions

DAILY EVENTS

Sponsored by  AIRCRAFT
WHEEL & BRAKE
BY KAMAN

Cleveland
Wheels & Brakes

TIME	PRESENTATION	SPEAKER	LOCATION	MAP	TYPE
TUESDAY, JULY 23, 2024					
9:00 AM - 9:45 AM	Lessons From the AT	Mark Boguski	NAFI Booth	J-14	F
9:00 AM - 10:00 AM	Intro to Rotax Aircraft Engines	Lauren Burton	Rotax Aircraft Engines Booth	J-12	F
9:00 AM - 10:00 AM	Design, Build, Fly: Airplane Sims	Embry-Riddle Aeronautical University	Embry-Riddle Booth 49	J-10	F
9:00 AM - 10:00 AM	GFC 500X Installation Basics	Garmin Aviation Team	Garmin Seminar Tent 1	K-13	F
9:00 AM - 10:00 AM	Get Started With Garmin Avionics	Garmin	Garmin Seminar Tent 2	K-13	F
9:00 AM - 10:00 AM	Plane Talk	Ryan Dembroski	Boeing Plaza	L-13	F
9:00 AM - 10:00 AM	Could I Be a Pilot?	Lauren Dalzell Settles	EAA Wearhouse	J-12	MG
9:00 AM - 10:00 AM	Stinson Aircraft Prewar History	Jody Jones	Vintage Hangar	K-15	F
9:00 AM - 10:15 AM	Servicing the Hubble	John Grunsfeld	EAA AeroEducate Forum Tent	I-10	F
9:00 AM - 11:00 AM	On the Grounds & Up	Jerry Burke	EAA Wearhouse	J-12	MG
9:00 AM - 11:30 AM	Ultralights and Lightplanes		Fun Fly Zone	K-20	SE
9:00 AM - 11:30 AM	COPA Safety Seminar: XC Flying	Conrad Hatcher	EAA Canada	K-12	F
9:00 AM - 12:00 PM	Paul's Vintage Workshop	Jim Hamilton	Vintage Hangar	K-15	W
9:15 AM - 9:30 AM	GE Aerospace Careers Open House	Talent Acquisition - GE Aerospace	GE Aerospace	K-14	MG
9:30 AM - 10:15 AM	Auto Ground Collision Avoidance	To Be Announced	International Federal Pavilion	I-13	F
9:30 AM - 10:30 AM	Wow, It's Windy	Greg Roark	Redbird Sim Lab	J-13	F
9:30 AM - 10:30 AM	GE Aerospace: CF34 Fan Maintenance	Jim Condon	GE Aerospace	K-14	F
9:30 AM - 10:45 AM	ATC & You: Mountains That Fool You	NATCA	NATCA Booth	J-10	F
9:30 AM - 11:30 AM	Lycoming Engine Lubrication Systems	Michael Damiani	Lycoming Engines Booth	J-12	D
10:00 AM - 10:30 AM	Avidyne IFD With iPad/ForeFlight	Randall Edwards	Avidyne Booth 3130A	I-12	F
10:00 AM - 10:45 AM	Departure Briefing	Collin McDonald	NAFI Booth	J-14	F
10:00 AM - 10:45 AM	SocialFlight Live: Talking Safety	Capt. Brian Schiff	AOPA Program Pavilion	L-11	F
10:00 AM - 11:00 AM	Setting Ring Gaps & Cylinder Life	Bill Ross	Superior Air Parts Booth	I-13	F
10:00 AM - 11:00 AM	Garmin Pilot App Tips & Tricks	Garmin	Garmin Seminar Tent 2	K-13	F
10:00 AM - 11:00 AM	VNAV with GTN Xi & GFC 500 Training	Garmin Aviation Team	Garmin Seminar Tent 1	K-13	F
10:00 AM - 11:00 AM	Continental's Guide to Reaching TBO	Tim Owen	Continental Aerospace Technologies	J-12	F
10:00 AM - 11:00 AM	Dick Rutan Memorial	Burt Rutan	Brown Arch - Gateway to Aviation	M-10	SE
10:00 AM - 11:00 AM	Behind My Wings	BJ Elliott Prior	EAA Wearhouse	J-12	MG
10:00 AM - 11:00 AM	Plane Talk	Ryan Dembroski	Boeing Plaza	L-13	F
10:00 AM - 11:00 AM	Cleveland Wheel & Brake Maintenance	Vern Rodgers	AeroShell Booth 446/457	L-11	F
10:00 AM - 11:00 AM	SkyView HDX in TC Aircraft Part 1/2	Dynon Staff	Dynon Tent	I-13	F
10:00 AM - 11:00 AM	Pilot Show-and-Tell	AC & Sue Hutson	Charles W. Harris Youth Aviation Center	L-15	F
10:00 AM - 11:00 AM	Aeronas: Bill's 45th Forum	Bill Pancake	Vintage Hangar	K-15	F
10:00 AM - 11:15 AM	Cessna A-37 Dragonflys	Hank Hoffman	Warbirds in Review	L-7	F
10:00 AM - 11:15 AM	Creating IMC/VMC Programs	Jim Lipscomb	EAA Blue Barn Featuring EAA Chapters, EAA Young Eagles, and EAA Eagle Flights	J-9	F
10:00 AM - 11:15 AM	Hartzell Composite Propellers 101	Aaron "Opie" Perry	Hartzell Propeller 296-297	J-13	F
10:00 AM - 11:15 AM	Transforming the Face of Aviation	Lynda Coffman	EAA WomenVenture Center	K-10	F
10:00 AM - 11:15 AM	Save Time & Money in Your Training	Larry Bothe	EAA Learn to Fly Center	J-13	F
10:00 AM - 11:15 AM	Annual Mooney Aircraft Forum	Chuck Crinnian	Forum Stage 1: WILCO	K-9	F
10:00 AM - 11:15 AM	AAM: Challenges and Innovations	Dr. Kyle Collins	Forum Stage 2: Aero Hose Shop	K-9	F
10:00 AM - 11:15 AM	Impossible Turns, Stall/Spins, AOA	Ed Wischmeyer	Forum Stage 3: Superflite	K-9	F
10:00 AM - 11:15 AM	Wittman Tailwind: Still Relevant	Keith Klos	Forum Stage 4: PilotSmith	J-9	F
10:00 AM - 11:15 AM	Designing the Perfect Paint Scheme	Craig Barnett	Forum Stage 5: Scheme Designers	J-9	F
10:00 AM - 11:15 AM	Fighter Combat WWII	Steve Church	Forum Stage 6: EnerSys	J-9	F
10:00 AM - 11:15 AM	Preflight Weather Tools: ForeFlight	ForeFlight	Forum Stage 7: ForeFlight	J-9	F
10:00 AM - 11:15 AM	MOSAIC Update	EAA Govt Advocacy Team	Forum Stage 8: GAMA	J-9	F
10:00 AM - 11:15 AM	Picture Your Plane	Edwin Remsberg	Forum Stage 9: SOFTIE PARACHUTES by Para-Phernalia Inc.	J-9	F
10:00 AM - 11:15 AM	Mechanics & the Law	EAA Legal Advisory Council	Forum Stage 10: Poly Fiber Inc.	K-9	F
10:00 AM - 11:15 AM	The B-1 Bomber	Kenneth Katz	Forum Stage 11: DeltaHawk Engines	K-9	F
10:00 AM - 11:15 AM	Stinson Aircraft Prewar History	Dave James	Workshop Classroom A	K-10	F
10:00 AM - 11:15 AM	Piston Engine Fuels	Jennifer Miller	Workshop Classroom B	K-10	F
10:00 AM - 11:15 AM	Priming Aluminum Correctly	Lars Gleitsmann	Workshop Classroom C	K-10	W
10:00 AM - 11:15 AM	Forming Basics	Mark Kennison	Aeroplane Workshop	L-9	W
10:00 AM - 11:15 AM	Getting Started in Aerobatics	Gordon Penner	International Aerobatic Club (IAC) Aerobatics Center	L-12	F
10:00 AM - 11:15 AM	Able Flight Wings Pinning Ceremony	Able Flight	Theater in the Woods Supported by M&M'S	K-15	SE
10:00 AM - 11:15 AM	NASM News: East Galleries Revealed	Dorothy Cochrane	EAA Museum - Vette Theater	B-8	F

Aviation Gateway
Park is presented by



AVIATION GATEWAY PARK™

AT EAA® AIRVENTURE® OSHKOSH™ 2024



Aviation Gateway Park is **your headquarters** for education, careers, and networking with aviation companies and industries.



EAA AeroEducate™ Center

Learn how students in grades K-12 can engage with the world of aviation during and after AirVenture! With AeroEducate, EAA's free, online education program, students from 5-18 years old can explore more than 200 activities designed to introduce them to aviation and aerospace career opportunities.



EAA Education and Career Center

Presented by Piedmont Airlines

The EAA Education Center will feature colleges, universities, and technical schools that offer programs in aviation and STEM-based curriculum. Attendees are also able to network and interview with a variety of leading aviation companies and organizations with aviation-focused career opportunities.



EAA Career Center

Presented by Air Wisconsin Airlines

If you're an aspiring aviator looking to network and interview with a variety of leading aviation companies and airlines, this is where you belong. Navigate your way into the aviation industry at the EAA Career Center.



Learn more at EAA.org/AGP

DAILY EVENTS

Sponsored by  AIRCRAFT
WHEEL & BRAKE
BY KAMAN

Cleveland
Wheels & Brakes

TIME	PRESENTATION	SPEAKER	LOCATION	MAP	TYPE
TUESDAY, JULY 23, 2024					
10:00 AM - 11:15 AM	The Leo Kohn Photography Collection	Kurt Stanich	EAA Museum - Hilton Theater	B-8	F
10:00 AM - 11:15 AM	Zeppelins, the First Airliners	John Mellberg	EAA Museum - Skyscape Theater	B-8	F
10:00 AM - 11:15 AM	Convert Stock Rotax 912 to TBI	Steve Schultz	Homebuilders Hangar Supported by Aircraft Spruce & Specialty	K-9	F
10:00 AM - 11:15 AM	Homebuilts in Review		Homebuilts in Review	K-9	F
10:00 AM - 11:15 AM	Swift Fuels Unleaded Avgas	Chris D'Acosta	Ultralight Forums Tent	K-18	F
10:00 AM - 11:30 AM	Coffee With Controllers	NATCA	NBAA Booth		MG
10:15 AM - 12:00 PM	GPS Resiliency	Vince Massimini	FAA Aviation Safety Center, Flight Service Station	J-11	F
10:30 AM - 11:00 AM	Meet Aero Performer Skip Stewart	William "Skip" Stewart	ALPA Booth 329	K-14	MG
10:30 AM - 11:15 AM	Preserving the Story of Aviation	Cliff Chetwin	International Federal Pavilion	I-13	F
10:30 AM - 11:45 AM	NASA Pilot Talk	April Lanotte	EAA AeroEducate Forum Tent	I-10	F
10:30 AM - 12:30 PM	Oh, the Places You'll Go!	Greg Roark	Redbird Sim Lab	J-13	F
10:45 AM - 12:00 PM	Vintage in Review	Ray Johnson	Rose Plaza Interview Circle	L-14	F
11:00 AM - 11:30 AM	Day in the Life of an Airline Pilot	F/O Justin Dahan	ALPA Booth 329	K-14	FE
11:00 AM - 11:30 AM	GE Aerospace Road Map for Flight	Melvyn Heard	GE Aerospace	K-14	F
11:00 AM - 11:30 AM	Let Your Pilot Career Take Flight	Southwest Airlines	Southwest Airlines	I-10	F
11:00 AM - 11:45 AM	Three Key Icing Lessons	Dr. Scott Dennstaedt	NAFI Booth	J-14	F
11:00 AM - 11:45 AM	Ask the A&Ps: Live	Mike Busch	AOPA Program Pavilion	L-11	F
11:00 AM - 12:00 PM	Cockpit Upgrades on a Budget	Garmin	Garmin Seminar Tent 2	K-13	F
11:00 AM - 12:00 PM	An In-Depth Look at GI 275	Garmin Aviation Team	Garmin Seminar Tent 1	K-13	F
11:00 AM - 12:00 PM	Plane Talk	Ryan Dembroski	Boeing Plaza	L-13	F
11:00 AM - 12:00 PM	Final Mission	Chris Henry	EAA Warehouse	J-12	MG
11:00 AM - 12:00 PM	Select the Best Piston Engine Oil	Piotr Gawecki	AeroShell Booth 446/457	L-11	F
11:00 AM - 12:00 PM	Swift Museum Foundation Forum	Jim Jones	Vintage Hangar	K-15	F
11:00 AM - 12:15 PM	ATC & You: David vs. Goliath	NATCA	NATCA Booth	J-10	F
11:00 AM - 12:45 PM	Women's Intro to Sheet Metal	Louise Hose	Sheet Metal Workshop Presented by Aircraft Spruce & Specialty	J-10	W
11:30 AM - 12:00 PM	What Are Canadian Ultralights?	Kathy Lubitz	EAA Canada	K-12	F
11:30 AM - 12:00 PM	Landing an Aviation Scholarship	F/O Camila Turrieta	ALPA Booth 329	K-14	FE
11:30 AM - 12:15 PM	UAS Operations	Jonathan Shannon	International Federal Pavilion	I-13	F
11:30 AM - 12:30 PM	A Pilot's Guide to Logbook Entries	Chuck Cook	Continental Aerospace Technologies	J-12	F
11:30 AM - 12:30 PM	Advanced Systems for Experimentals	AFS Staff	Dynon Tent	I-13	F
11:30 AM - 12:45 PM	Mental Health Issues in FAA Medical	EAA Aeromedical Advisory Council	EAA Learn to Fly Center	J-13	F
11:30 AM - 12:45 PM	Worldwide Women Pilots	Jenny Beatty	EAA WomenVenture Center	K-10	F
11:30 AM - 12:45 PM	Young Eagles Registration Web Tools	David Leiting	EAA Blue Barn Featuring EAA Chapters, EAA Young Eagles, and EAA Eagle Flights	J-9	F
11:30 AM - 12:45 PM	Welding Basics	Budd Davison	Forum Stage 1: WILCO	K-9	F
11:30 AM - 12:45 PM	Building a Part 135 Drone Airline	Zipline	Forum Stage 2: Aero Hose Shop	K-9	F
11:30 AM - 12:45 PM	Choosing a Fabric Covering System	Molly Dean	Forum Stage 3: Superflite	K-9	F
11:30 AM - 12:45 PM	Flying With a Purpose	Jim Hessemann	Forum Stage 4: Pilotsmith	J-9	F
11:30 AM - 12:45 PM	Shuttle, Houston	Paul Dye	Forum Stage 5: Scheme Designers	J-9	F
11:30 AM - 12:45 PM	NASA's Next X-Plane: The Truss	Kate McMurtry	Forum Stage 6: EnerSys	J-9	F
11:30 AM - 12:45 PM	History of Homebuilt Canards	Burt Rutan	Forum Stage 7: ForeFlight	J-9	F
11:30 AM - 12:45 PM	SR-71 and the Blackbird Family	Phil Soucy	Forum Stage 8: GAMA	J-9	F
11:30 AM - 12:45 PM	Rivets & Sheet Metal Construction	Sebastien Heintz	Forum Stage 9: SOFTIE PARACHUTES by Para-Pernalia Inc.	J-9	F
11:30 AM - 12:45 PM	How to Shoot Award-Winning Photos	Mike Lavitt	Forum Stage 10: Poly Fiber Inc.	K-9	F
11:30 AM - 12:45 PM	ForeFlight IFR Real-World Pro Tips	Gary Reeves	Forum Stage 11: DeltaHawk Engines	K-9	F
11:30 AM - 12:45 PM	Advanced Composites: Vacuum Bagging	Scott VanderVeen	Workshop Classroom A	K-10	W
11:30 AM - 12:45 PM	Engine Performance Machining	Archie Frangoudis	Workshop Classroom B	K-10	F
11:30 AM - 12:45 PM	Corvair Flight Engines	William Wynne	Workshop Classroom C	K-10	F
11:30 AM - 12:45 PM	Aerodynamics and Aerobatics	Dagmar Kress	International Aerobatic Club (IAC) Aerobatics Center	L-12	F
11:30 AM - 12:45 PM	F-35 Ejection Gone Viral	Tyler Shaver	EAA Museum - Vette Theater	B-8	FE
11:30 AM - 12:45 PM	Generative AI for Aviation	Aditya Mohan	EAA Museum - Hilton Theater	B-8	F
11:30 AM - 12:45 PM	Spy Pilot	Gary Powers Jr.	EAA Museum - Skyscape Theater	B-8	F
11:30 AM - 12:45 PM	Hartzell Props for Homebuilts	Trevor Parker	Homebuilders Hangar Supported by Aircraft Spruce & Specialty	K-9	F
11:30 AM - 12:45 PM	Trailers for Ultralight/Light Sport	Mike Ostrander	Ultralight Forums Tent	K-18	F
11:30 AM - 2:00 PM	Homebuilt Rotorcraft		Fun Fly Zone	K-20	SE

EAA AIRVENTURE
OSHKOSH
2024

JOIN US AT EAA® WOMENVENTURE™
CENTER—ALL WEEK!

MONDAY, JULY 22

ICE CREAM SOCIAL | 3 P.M. | EAA® WOMENVENTURE™ CENTER

Sponsored by Endeavor Air

WEDNESDAY, JULY 24

ANNUAL PHOTO | 11 A.M. | BOEING PLAZA

Wear your 2024 WomenVenture T-Shirt and join us in Boeing Plaza for the annual group photo.

POWER LUNCH | 11:30 A.M. | THEATER IN THE WOODS

Featuring Nicole Battjes, CEO of Rainbow Helicopters

EAA® WOMENVENTURE™ PANEL | 6:30 P.M. | THEATER IN THE WOODS

Exploring the Evolution of Women in the Vertical Lift Industry

THURSDAY, JULY 25

AUTHORS CORNER | 9 A.M.—5 P.M. | EAA® WOMENVENTURE™ CENTER

Featuring female authors.

EAA
WomenVenture™
PASSION.
COMMUNITY.
AVIATION.

Presented by:



Check out **EAA.ORG/WOMENVENTURE**
to keep up to date on events throughout the week!

DAILY EVENTS

Sponsored by  **AIRCRAFT
WHEEL & BRAKE**
BY KAMAN

Cleveland
Wheels & Brakes

TIME	PRESENTATION	SPEAKER	LOCATION	MAP	TYPE
TUESDAY, JULY 23, 2024					
12:00 PM - 12:30 PM	Avidyne IFD With Portable Devices	Randall Edwards	Avidyne Booth 3130A	I-12	F
12:00 PM - 12:30 PM	Pathways to the Airlines	F/O Mark Lockwood	ALPA Booth 329	K-14	FE
12:00 PM - 12:45 PM	Caution: Helicopter Wake Turbulence	Ned Parks	NAFI Booth	J-14	F
12:00 PM - 12:45 PM	Navigating the Traffic Pattern	Tom Letts	AOPA Program Pavilion	L-11	F
12:00 PM - 1:00 PM	Meet Air Show Performer Kyle Fowler		EAA Canada	K-12	MG
12:00 PM - 1:00 PM	Garmin Engine Monitor Solutions	Garmin	Garmin Seminar Tent 2	K-13	F
12:00 PM - 1:00 PM	GNS Transition: Find Your Next GPS	Garmin Aviation Team	Garmin Seminar Tent 1	K-13	F
12:00 PM - 1:00 PM	Plane Talk	Ryan Dembroski	Boeing Plaza	L-13	F
12:00 PM - 1:00 PM	Flight Lines	Kent Smerdon	EAA Wearhouse	J-12	MG
12:00 PM - 1:00 PM	Engine Longevity: How to Protect It	Steven Boggess	AeroShell Booth 446/457	L-11	F
12:00 PM - 2:00 PM	Postmortem or Premortem	Bruce Webb	FAA Aviation Safety Center, Flight Service Station	J-11	F
12:00 PM - 5:00 PM	Type Clubs	Charlie Waterhouse	Vintage Hangar	K-15	F
12:30 PM - 1:00 PM	Military Vets to Airline Jets	Air Line Pilots Association	ALPA Booth 329	K-14	FE
12:30 PM - 1:15 PM	How We Respond to Beacon Activation	Allan Knox	International Federal Pavilion	I-13	F
12:30 PM - 1:45 PM	ATC & You: Real-World Lessons Ch 2	NATCA	NATCA Booth	J-10	F
12:45 PM - 2:00 PM	Self-Fly African Safaris	Jim Moshonsky	EAA Canada	K-12	F
1:00 PM - 1:30 PM	Hand Propping Demonstration	Dion Carr	Rose Plaza Interview Circle	L-14	D
1:00 PM - 1:30 PM	Let Your Pilot Career Take Flight	Southwest Airlines	Southwest Airlines	I-10	F
1:00 PM - 1:45 PM	Flight Guidelines	Jolie Lucas	NAFI Booth	J-14	F
1:00 PM - 1:45 PM	Safety and Social Media	Chris Palmer	AOPA Program Pavilion	L-11	F
1:00 PM - 2:00 PM	Your Next Autopilot: GFC 500/600	Garmin Aviation Team	Garmin Seminar Tent 1	K-13	F
1:00 PM - 2:00 PM	How to Plan and Shop for Avionics	Garmin	Garmin Seminar Tent 2	K-13	F
1:00 PM - 2:00 PM	Plane Talk	Ryan Dembroski	Boeing Plaza	L-13	F
1:00 PM - 2:00 PM	Aviatrix and The Firsts	Mary Shipko	EAA Wearhouse	J-12	MG
1:00 PM - 2:00 PM	Rotax Injected Installation Info	Dean Vogel	Rotax Aircraft Engines Booth	J-12	F
1:00 PM - 2:00 PM	SkyView HDX in TC Aircraft Part 2/2	Dynon Staff	Dynon Tent	I-13	F
1:00 PM - 2:00 PM	GE Aerospace: CF34 Fan Maintenance	Jim Condon	GE Aerospace	K-14	F
1:00 PM - 2:00 PM	Design, Build, Fly: Airplane Sims	Embry-Riddle Aeronautical University	Embry-Riddle Booth 49	J-10	F
1:00 PM - 2:15 PM	Pass the FAA Knowledge Test	Bret Kobbe	EAA Learn to Fly Center	J-13	F
1:00 PM - 2:15 PM	A Conversation With Pilot Julia	Julia Harrington	EAA WomenVenture Center	K-10	F
1:00 PM - 2:15 PM	Create a Dynamic Chapter Newsletter	Chuck Fisher	EAA Blue Barn Featuring EAA Chapters, EAA Young Eagles, and EAA Eagle Flights	J-9	F
1:00 PM - 2:15 PM	P-51B and P-51D Old Crow Mustangs	To Be Announced	Warbirds in Review	L-7	SE
1:00 PM - 2:15 PM	AFWERX Prime Overview and Successes	Brooke Ezell	Forum Stage 1: WILCO	K-9	F
1:00 PM - 2:15 PM	Lithium Battery Use in Aircraft	Reginald Nicoson	Forum Stage 2: Aero Hose Shop	K-9	F
1:00 PM - 2:15 PM	Mayday: SEL IFR Engine Failure	George Gratton	Forum Stage 3: Superlite	K-9	F
1:00 PM - 2:15 PM	An ATC View of Inadvertent IMC	Dean Brown	Forum Stage 4: Pilotsmith	J-9	F
1:00 PM - 2:15 PM	Whale Alert: Pilot Citizen Science	Virgil Zetterlind	Forum Stage 5: Scheme Designers	J-9	F
1:00 PM - 2:15 PM	Boeing's Expansion to SC	Mark Fava	Forum Stage 6: EnerSys	J-9	F
1:00 PM - 2:15 PM	Postflight Tools in ForeFlight	ForeFlight	Forum Stage 7: ForeFlight	J-9	F
1:00 PM - 2:15 PM	Mechanic Crisis	Mike Busch	Forum Stage 8: GAMA	J-9	F
1:00 PM - 2:15 PM	Buying Aircraft You Can't Insure?	Scott "Sky" Smith	Forum Stage 9: SOFTIE PARACHUTES by Para-Phernalia Inc.	J-9	F
1:00 PM - 2:15 PM	Fabric Covering 101	EAA SportAir	Forum Stage 10: Poly Fiber Inc.	K-9	W
1:00 PM - 2:15 PM	The D-Day Doll DC-3	Chiawei "Fug" Lee	Forum Stage 11: DeltaHawk Engines	K-9	F
1:00 PM - 2:15 PM	Sheet Metal 101	EAA SportAir Sheet Metal	Sheet Metal Workshop Presented by Aircraft Spruce & Specialty	J-10	W
1:00 PM - 2:15 PM	Composite 101	EAA SportAir Composites	Workshop Classroom A	K-10	W
1:00 PM - 2:15 PM	Wood Construction 101	EAA SportAir Wood	Wood Workshop	K-10	W
1:00 PM - 2:15 PM	Proper Composite Repair Techniques	D. Michael Bergen	Workshop Classroom B	K-10	F
1:00 PM - 2:15 PM	Gas Welding 101	EAA SportAir Gas Welding	Gas Welding Workshop	K-10	W
1:00 PM - 2:15 PM	PIREPs Made Simple	Purdue University	Workshop Classroom C	K-10	F
1:00 PM - 2:15 PM	Power Hammer	Mark Kennison	Aeroplane Workshop	L-9	W
1:00 PM - 2:15 PM	Bucker: Stradivarius of Biplanes	Gail Schipper	International Aerobatic Club (IAC) Aerobatics Center	L-12	F
1:00 PM - 2:15 PM	Chasing Planes TV Show	Gordon Page	EAA Museum - Vette Theater	B-8	F
1:00 PM - 2:15 PM	Lincoln Beachey: Best Early Pilot	Richard Wetherald	EAA Museum - Hilton Theater	B-8	F
1:00 PM - 2:15 PM	Exotic Aircraft of Walter Soplatá	Wally Soplatá	EAA Museum - Skyscape Theater	B-8	F
1:00 PM - 2:15 PM	Amateur-Built Certification	Timm Bogenhagen	Homebuilders Hangar Supported by Aircraft Spruce & Specialty	K-9	F



EAA's Pilot Proficiency Center is a skill-building and training facility for those with a desire to increase their knowledge and hone their abilities. Redbird LD Advanced Training Devices are available for solo flight training or with an EAA® Instructor Pilot throughout the year.

Visit EAA.org/PPC for more information on available resources, training, classes, and more.

Sponsored by:



EAA Young Eagles

Inspire the Next Generation

After 30 years of providing free flights for youths aged 8–17, now is your chance to get involved and share The Spirit of Aviation®. Visit the EAA Blue Barn to learn more!

Next steps also available at EAA.org/YEPilots



EAA Young Eagles
Presenting Sponsor



Official Airline of
EAA Young Eagles



EAA Young Eagles
Flight Plan Partners



EAA Young Eagles
Supporting Sponsors



DAILY EVENTS

Sponsored by  AIRCRAFT
WHEEL & BRAKE
BY KAMAN

Cleveland
Wheels & Brakes

TIME	PRESENTATION	SPEAKER	LOCATION	MAP	TYPE
TUESDAY, JULY 23, 2024					
1:00 PM - 2:15 PM	Homebuilts in Review		Homebuilts in Review	K-9	F
1:00 PM - 2:15 PM	Annual Inspection for Ultralights	Dennis Demeter	Ultralight Forums Tent	K-18	F
1:00 PM - 2:30 PM	Vintage Children's Workshop	AC & Sue Hutson	Charles W. Harris Youth Aviation Center	L-15	W
1:00 PM - 3:00 PM	Reassembly of a Lycoming Engine	Michael Damiani	Lycoming Engines Booth	J-12	D
1:00 PM - 4:00 PM	TIG Welding 101	EAA SportAir TIG Welding	TIG Welding Workshop Presented by Lincoln Electric	K-10	W
1:15 PM - 2:00 PM	Empowering Pilots With Data	Johnathan Morrell	GE Aerospace	K-14	F
1:30 PM - 2:15 PM	TFRs: How to Avoid an Intercept	Lt. Col. Trevor "Boat" Boswell	International Federal Pavilion	I-13	F
1:30 PM - 2:30 PM	Application of Graphical Forecasts	Dr. Terry Lankford	EAA Seaplane Base Presented by Wipaire	Seaplane Base	F
1:30 PM - 2:30 PM	Cable Splicing Demonstration	Dave Wenglarz	Vintage Hangar	K-15	D
2:00 PM - 2:30 PM	GNS-to-IFD in Experimental Aircraft	Tom Harper	Avidyne Booth 3130A	I-12	F
2:00 PM - 2:45 PM	Aircraft Insurance: Need-to-Knows	Cher Clare	AOPA Program Pavilion	L-11	F
2:00 PM - 3:00 PM	Building Your Experimental Panel	Garmin	Garmin Seminar Tent 2	K-13	F
2:00 PM - 3:00 PM	Choosing a Garmin PFD/MFD	Garmin Aviation Team	Garmin Seminar Tent 1	K-13	F
2:00 PM - 3:00 PM	The Supersonic Bone	Kenneth Katz	EAA Wearhouse	J-12	MG
2:00 PM - 3:15 PM	Flying to and From Canada	Ian Brown	EAA Canada	K-12	F
2:00 PM - 3:30 PM	How to Talk Pilot	Greg Roark	Redbird Sim Lab	J-13	F
2:00 PM - 4:00 PM	Loss of Control on Land and Water	Steve Guetter	FAA Aviation Safety Center, Flight Service Station	J-11	F
2:15 PM - 6:00 PM	Tuesday Air Show	EAA	Air Show	M-13	A
2:30 PM - 3:15 PM	Flying to the Bahamas	To Be Announced	International Federal Pavilion	I-13	F
2:30 PM - 3:45 PM	Women Advancing Tech in Aviation	ForeFlight	EAA WomenVenture Center	K-10	F
2:30 PM - 3:45 PM	Hypoxia & O2	Scott Ashton	Forum Stage 1: WILCO	K-9	F
2:30 PM - 3:45 PM	Propelling Change: UND and UL94	Dr. Robert Kraus	Forum Stage 2: Aero Hose Shop	K-9	F
2:30 PM - 3:45 PM	Cold War Defense of the West	John Bronson	Forum Stage 3: Superflite	K-9	F
2:30 PM - 3:45 PM	Aviation Video Tips & Techniques	Daniel Millican	Forum Stage 4: Pilotsmith	J-9	F
2:30 PM - 3:45 PM	Mountain Flying in New Zealand	Matt and Jo McCaughan	Forum Stage 5: Scheme Designers	J-9	F
2:30 PM - 3:45 PM	Learn More About Twin Cessnas	The Twin Cessna Flyer	Forum Stage 6: EnerSys	J-9	F
2:30 PM - 3:45 PM	IFR Made Easy	Gary Reeves	Forum Stage 7: ForeFlight	J-9	F
2:30 PM - 3:45 PM	Annual Inspection: Good, Bad, Ugly	Mike Busch	Forum Stage 8: GAMA	J-9	F
2:30 PM - 3:45 PM	Mastering the Tailwheel	Budd Davisson	Forum Stage 9: SOFTIE PARACHUTES by Para-Phernalia Inc.	J-9	F
2:30 PM - 3:45 PM	How to Think Like John Roncz	Jac van Egmond	Forum Stage 10: Poly Fiber Inc.	K-9	F
2:30 PM - 3:45 PM	Fly New Mexico's History and Wilds	Ken Summers	Forum Stage 11: DeltaHawk Engines	K-9	F
2:30 PM - 3:45 PM	Franklin Engine Evolution	Dave James	Workshop Classroom A	K-10	F
2:30 PM - 3:45 PM	Introducing the Motor Balloon	Daniel Nachbar	Workshop Classroom B	K-10	F
2:30 PM - 3:45 PM	Gas Welding Aluminum	EAA SportAir Gas Welding	Gas Welding Workshop	K-10	W
2:30 PM - 3:45 PM	Advanced Forming	Mark Kennison	Aeroplane Workshop	L-9	W
2:30 PM - 3:45 PM	My Life: Fast Cars and Airplanes	Paul T. Glessner	EAA Museum - Vette Theater	B-8	F
2:30 PM - 3:45 PM	Lighter-Than-Air in the Great War	Kip Lankenau	EAA Museum - Hilton Theater	B-8	F
2:30 PM - 3:45 PM	Bugatti's Unfulfilled Dream	John Mellberg	EAA Museum - Skyscape Theater	B-8	F
2:30 PM - 3:45 PM	AB Aircraft Engine Inspection	Vic Syracuse	Homebuilders Hangar Supported by Aircraft Spruce & Specialty	K-9	F
2:30 PM - 3:45 PM	14-Year-Old Alina's Solo Adventure	Alina and William Scott	Ultralight Forums Tent	K-18	F
3:00 PM - 3:45 PM	Primacy in Training for Emergencies	Jason Blair	AOPA Program Pavilion	L-11	F
3:00 PM - 4:00 PM	Fly Girls Revolt	Eileen Bjorkman	EAA Wearhouse	J-12	MG
3:30 PM - 4:15 PM	Heliport Criteria	Paul Causey	International Federal Pavilion	I-13	FE
3:30 PM - 5:30 PM	Borescope Inspection Workshop	David Pasquale	Workshop Classroom C	K-10	W
4:00 PM - 4:45 PM	Aviation Weather Q&A Panel	Dr. Ian Johnson	AOPA Program Pavilion	L-11	F
4:00 PM - 5:00 PM	Wings of Gold	Beverly Weintraub	EAA Wearhouse	J-12	MG
4:00 PM - 5:15 PM	Ascending Higher: Breaking Barriers	Annie Driscoll	EAA WomenVenture Center	K-10	F
4:00 PM - 5:15 PM	How to Be a Successful Career CFI	Toby Rice	Forum Stage 1: WILCO	K-9	F
4:00 PM - 5:15 PM	Never Rib Stitch or Pop Rivet Again	Siegfried Lanitz	Forum Stage 2: Aero Hose Shop	J-9	F
4:00 PM - 5:15 PM	Breathing Above 8K: More Than PO2	James Runnels	Forum Stage 4: Pilotsmith	J-9	F
4:00 PM - 5:15 PM	The Wonderful Warthog, Part 2	Buck Wyndham	Forum Stage 7: ForeFlight	J-9	F
4:00 PM - 5:15 PM	African Air Safari: Fly Wild	Sjoerd Jan ter Welle	Forum Stage 10: Poly Fiber Inc.	K-9	F
4:00 PM - 5:15 PM	Youth Aviation Programs	Steve Wathen	Workshop Classroom A	K-10	F
4:00 PM - 5:15 PM	Encountering UAPs (UFOs)	Cameron Khan	EAA Museum - Hilton Theater	B-8	F
4:00 PM - 5:15 PM	Badlands Aircraft Part 103	Chris Deuel	Ultralight Forums Tent	K-18	F



Now Showing

**SATURDAY
JULY 20**
Top Gun
(8:30 p.m.)

**SUNDAY
JULY 21**
A Million Miles Away
(8:30 p.m.)

**MONDAY
JULY 22**
Fighter Squadron
(8:30 p.m.)

**TUESDAY
JULY 23**
Toward the Unknown
(8:30 p.m.)

**WEDNESDAY
JULY 24**
Fire Birds
(8:30 p.m.)

**THURSDAY
JULY 25**
*Captains of
the Clouds*
(8:30 p.m.)

**FRIDAY
JULY 26**
The Blue Angels
(8:30 p.m.)

**SATURDAY
JULY 27**
The Right Stuff
(8:30 p.m.)

Gather up your friends and family, pack your blanket or lawn chairs and settle in to an outdoor movie experience that is one-of-a-kind! Relax and unwind while watching blockbuster and classic aviation movies on a five-story high screen.



Presented by  **LYCOMING**

**EAA AIRVENTURE
OSHKOSH
2024**

TAKE YOUR CAREER TO NEW HEIGHTS



Whether you're seeking a position in the aviation industry, wondering what career options are available, or simply looking for a professional change of pace, AirVenture® is the place to be. Visit participating exhibitors in the Aviation Job Fair at their exhibit booth and take your career to new heights!

Supported by  **JSfirm.com**

**EAA AIRVENTURE
OSHKOSH**

To view a list of participating exhibitors, or to learn more, visit

EAA.org/JobFair

DAILY EVENTS

Sponsored by  AIRCRAFT
WHEEL & BRAKE
BY KAMAN

Cleveland
Wheels & Brakes

TIME	PRESENTATION	SPEAKER	LOCATION	MAP	TYPE
TUESDAY, JULY 23, 2024					
4:00 PM - 6:00 PM	How to Avoid a Fighter Intercept	Lt. Col. Trevor "Boat" Boswell	FAA Aviation Safety Center, Flight Service Station	J-11	F
5:00 PM - 6:00 PM	Turret Tales	Judie Ohm	EAA Wearhouse	J-12	MG
5:00 PM - 6:00 PM	COPA BBQ		EAA Canada	K-12	SE
5:30 PM - 6:45 PM	Aviation Photographers Gathering	David Powell	Forum Stage 10: Poly Fiber Inc.	K-9	SE
6:00 PM - 8:00 PM	Vintage Teen Night	AC & Sue Hutson	Charles W. Harris Youth Aviation Center	L-15	F
6:30 PM - 7:30 PM	Ultralights and Lightplanes		Fun Fly Zone	K-20	SE
7:00 PM - 10:30 PM	D-Day & the Push to Victory in WWII		Theater in the Woods Supported by M&M'S	K-15	SE
7:30 PM - 8:00 PM	Powered Parachutes		Fun Fly Zone	K-20	SE
8:00 PM - 9:45 PM	Twilight Flight Fest		Fun Fly Zone	K-20	SE
8:30 PM - 9:30 PM	Balloon Glow		Fun Fly Zone	K-20	SE
8:30 PM - 10:45 PM	Toward the Unknown		Fly-In Theater Presented by Lycoming	E-13	M
WEDNESDAY, JULY 24, 2024					
7:00 AM - 7:45 AM	Fellowship of the Wing		Chapel and Compass Hill	E-8	CS
7:00 AM - 8:00 AM	Zumba With Oshkosh YMCA	Sue Williams	EAA WomenVenture Center	K-10	F
7:00 AM - 9:00 AM	Powered Parachutes		Fun Fly Zone	K-20	SE
7:00 AM - 9:00 AM	Balloon Static Inflation		Fun Fly Zone	K-20	SE
8:00 AM - 8:45 AM	Liability for CFIs	Jeff Edwards	NAFI Booth	J-14	F
8:00 AM - 9:00 AM	Pilot Training With GFC 500X	Garmin	Garmin Seminar Tent 2	K-13	F
8:00 AM - 9:00 AM	G3X Touch Wiring & Data Buses	Garmin Aviation Team	Garmin Seminar Tent 1	K-13	F
8:00 AM - 9:00 AM	National Aeronca Association Forum	Lt. Col. Craig MacVeigh	Vintage Hangar	K-15	F
8:00 AM - 9:15 AM	ATC & You: Clouds That Fool You	NATCA	NATCA Booth	J-10	F
8:00 AM - 12:00 PM	Metal Shaping Demonstration	Dave Wenglarz	Vintage Hangar	K-15	D
8:30 AM - 9:30 AM	Can I Run My Engine Lean of Peak?	Chuck Cook	Continental Aerospace Technologies	J-12	F
8:30 AM - 9:45 AM	Strategies for Growing Your Chapter	Gordon Davis	EAA Blue Barn Featuring EAA Chapters, EAA Young Eagles, and EAA Eagle Flights	J-9	F
8:30 AM - 9:45 AM	Women of NASA	Robert Margetta	EAA WomenVenture Center	K-10	F
8:30 AM - 9:45 AM	Mental Health Topics in Aviation	Industry Advocates	EAA Learn to Fly Center	J-13	F
8:30 AM - 9:45 AM	Oil Analysis: Best Practices	Amanda Callahan	Forum Stage 1: WILCO	K-9	F
8:30 AM - 9:45 AM	FlyQ Feature Road Map Discussion	Steve Podradchik	Forum Stage 2: Aero Hose Shop	K-9	F
8:30 AM - 9:45 AM	Superflite Rib Stitching & Repairs	Molly Dean	Forum Stage 3: Superflite	K-9	F
8:30 AM - 9:45 AM	Aviation Insurance 101	Alon Admi	Forum Stage 4: Pilotsmith	J-9	F
8:30 AM - 9:45 AM	Electronic Ignition Systems	Michael Kobyluk	Forum Stage 5: Scheme Designers	J-9	F
8:30 AM - 9:45 AM	AV-30/tailBeaconX Installation	uAvionix	Forum Stage 6: EnerSys	J-9	F
8:30 AM - 9:45 AM	How to Coexist With Weather	Jeff Arnold	Forum Stage 8: GAMA	J-9	F
8:30 AM - 9:45 AM	Flying Through Military Airspace	James Baker	Forum Stage 9: SOFTIE PARACHUTES by Para-Phernalia Inc.	J-9	F
8:30 AM - 9:45 AM	Fabric Covering 101	EAA SportAir	Forum Stage 10: Poly Fiber Inc.	K-9	W
8:30 AM - 9:45 AM	UL100E PAFI Testing Update	Dan Pourreau	Forum Stage 11: DeltaHawk Engines	K-9	F
8:30 AM - 9:45 AM	Sheet Metal 101	EAA SportAir Sheet Metal	Sheet Metal Workshop Presented by Aircraft Spruce & Specialty	J-10	W
8:30 AM - 9:45 AM	Composite 101	EAA SportAir Composites	Workshop Classroom A	K-10	W
8:30 AM - 9:45 AM	Wood Construction 101	EAA SportAir Wood	Wood Workshop	K-10	W
8:30 AM - 9:45 AM	Pitfalls in Oxygen Use	Sergio Seoane	Workshop Classroom B	K-10	F
8:30 AM - 9:45 AM	Gas Welding 101	EAA SportAir Gas Welding	Gas Welding Workshop	K-10	W
8:30 AM - 9:45 AM	Overview of the PT6	Robert Craymer	Workshop Classroom C	K-10	F
8:30 AM - 9:45 AM	Start a Collegiate Aerobatic Team	Nina Stewart	International Aerobatic Club (IAC) Aerobatics Center	L-12	F
8:30 AM - 9:45 AM	EAA Annual Business Meeting		Theater in the Woods Supported by M&M'S	K-15	SE
8:30 AM - 9:45 AM	Douglas Skyrocket to Mach 2	Cam Martin	EAA Museum - Vette Theater	B-8	F
8:30 AM - 9:45 AM	The Apollo 1 Fire: A Reexamination	George Leopold	EAA Museum - Hilton Theater	B-8	F
8:30 AM - 9:45 AM	Flying to Alaska	Vic Syracuse	Homebuilders Hangar Supported by Aircraft Spruce & Specialty	K-9	F
8:30 AM - 10:15 AM	Learning or Training	Bruce Webb	FAA Aviation Safety Center, Flight Service Station	J-11	F
8:30 AM - 11:45 AM	Rusty Pilots	Chris Moser	AOPA Program Pavilion	L-11	F
8:30 AM - 12:00 PM	TIG Welding 101	EAA SportAir TIG Welding	TIG Welding Workshop Presented by Lincoln Electric	K-10	W
8:30 AM - 2:30 PM	Homebuilders Workshop Acro/Sonex	Aeroplane Workshop Volunteers	Aeroplane Workshop	L-9	D
8:30 AM - 2:30 PM	Cozy Aircraft Build		Aeroplane Workshop	L-9	D
8:30 AM - 2:30 PM	Fabric Covering Demonstration		Aeroplane Workshop	L-9	D

TIME	PRESENTATION	SPEAKER	LOCATION	MAP	TYPE
WEDNESDAY, JULY 24, 2024					
8:30 AM - 2:30 PM	Player Special Restoration		Aeroplane Workshop	L-9	D
8:30 AM - 3:45 PM	Zenith Kit Assembly Demonstration		Aeroplane Workshop	L-9	D
9:00 AM - 9:30 AM	3D	Mark Kennison	Aeroplane Workshop	L-9	W
9:00 AM - 9:45 AM	Rotax 503 Teardown and Assembly	Jeff Howell	Ultralight Workshop Tent	K-18	F
9:00 AM - 9:45 AM	Physician Alerts: Mental Health	Dr. Victor Vogel	NAFI Booth	J-14	F
9:00 AM - 10:00 AM	Intro to Rotax Aircraft Engines	Lauren Burton	Rotax Aircraft Engines Booth	J-12	F
9:00 AM - 10:00 AM	Design, Build, Fly: Airplane Sims	Embry-Riddle Aeronautical University	Embry-Riddle Booth 49	J-10	F
9:00 AM - 10:00 AM	Finding Answers in Garmin Documents	Garmin Aviation Team	Garmin Seminar Tent 1	K-13	F
9:00 AM - 10:00 AM	GTN/GTN Xi Training: Tips & Tricks	Garmin	Garmin Seminar Tent 2	K-13	F
9:00 AM - 10:00 AM	Plane Talk	Ryan Dembroski	Boeing Plaza	L-13	F
9:00 AM - 10:00 AM	Shuttle, Houston	Paul Dye	EAA Wearhouse	J-12	MG
9:00 AM - 10:00 AM	Walk-Around of a Fabric Piper	Clyde Smith	Vintage Hangar	K-15	F
9:00 AM - 10:15 AM	Flying to and From Canada	Ian Brown	EAA Canada	K-12	F
9:00 AM - 10:15 AM	ANG: Pilot Career Pathways	Alex Abbott	EAA AeroEducate Forum Tent	I-10	F
9:00 AM - 11:00 AM	On the Grounds & Up	Jerry Burke	EAA Wearhouse	J-12	MG
9:00 AM - 11:30 AM	Ultralights and Lightplanes		Fun Fly Zone	K-20	SE
9:00 AM - 12:00 PM	Paul's Vintage Workshop	Jim Hamilton	Vintage Hangar	K-15	W
9:15 AM - 9:30 AM	GE Aerospace Careers Open House	Talent Acquisition - GE Aerospace	GE Aerospace	K-14	MG
9:30 AM - 10:15 AM	Solving Conservation Problems	Garrett Wilkerson	International Federal Pavilion	I-13	F
9:30 AM - 10:30 AM	What Makes an Airplane Fly?	Greg Roark	Redbird Sim Lab	J-13	F
9:30 AM - 10:45 AM	ATC & You: Next-Level Flying	NATCA	NATCA Booth	J-10	F
9:30 AM - 11:30 AM	Lycoming Engine Fuel Injection	Michael Damiani	Lycoming Engines Booth	J-12	D
10:00 AM - 10:30 AM	Hand Propping Demonstration	Dion Carr	Rose Plaza Interview Circle	L-14	D
10:00 AM - 10:45 AM	Vintage Flight Training	Mary Schu	NAFI Booth	J-14	F
10:00 AM - 10:45 AM	Rotax 503 Teardown and Assembly	Jeff Howell	Ultralight Workshop Tent	K-18	F
10:00 AM - 11:00 AM	Risks of Aircraft Engine Neglect	Bill Ross	Superior Air Parts Booth	I-13	F
10:00 AM - 11:00 AM	Getting Started With Garmin Pilot	Garmin	Garmin Seminar Tent 2	K-13	F
10:00 AM - 11:00 AM	Flying With G3X Touch Training	Garmin Aviation Team	Garmin Seminar Tent 1	K-13	F
10:00 AM - 11:00 AM	Continental's Guide to Reaching TBO	Tim Owen	Continental Aerospace Technologies	J-12	F
10:00 AM - 11:00 AM	Thundermouse	Caroline "Blaze" Jensen	EAA Wearhouse	J-12	MG
10:00 AM - 11:00 AM	Plane Talk	Ryan Dembroski	Boeing Plaza	L-13	F
10:00 AM - 11:00 AM	Aircraft Tire Care and Maintenance	Mary Beth Widak	AeroShell Booth 446/457	L-11	F
10:00 AM - 11:00 AM	Using SkyView HDX: Fundamentals	Dynon Staff	Dynon Tent	I-13	F
10:00 AM - 11:00 AM	Pilot Show-and-Tell	AC & Sue Hutson	Charles W. Harris Youth Aviation Center	L-15	F
10:00 AM - 11:00 AM	GE Aerospace: CF34 Fan Maintenance	Jim Condon	GE Aerospace	K-14	F
10:00 AM - 11:00 AM	Cookies With the Colleges	Embry-Riddle Aeronautical University	Embry-Riddle Booth 49	J-10	F
10:00 AM - 11:00 AM	Franklin Engine Evolution	Dave James	Vintage Hangar	K-15	F
10:00 AM - 11:15 AM	English Airplanes of WWII	Colin S. Bell	Warbirds in Review	L-7	F
10:00 AM - 11:15 AM	EAA Young Eagles Rally Planning	David Leitng	EAA Blue Barn Featuring EAA Chapters, EAA Young Eagles, and EAA Eagle Flights	J-9	F
10:00 AM - 11:15 AM	Pass Your Checkride (Oral Exam)	Larry Bothe	EAA Learn to Fly Center	J-13	F
10:00 AM - 11:15 AM	Extend the Life of Your Propeller	Aaron "Opie" Perry	Hartzell Propeller 296-297	J-13	F
10:00 AM - 11:15 AM	Civil Air Patrol in WWII	Sean Neal	Forum Stage 1: WILCO	K-9	F
10:00 AM - 11:15 AM	Legal Issues in Medical Certificate	EAA Legal Advisory Council	Forum Stage 2: Aero Hose Shop	K-9	F
10:00 AM - 11:15 AM	Air Navigation: How We Got Here	John Bronson	Forum Stage 3: Superflite	K-9	F
10:00 AM - 11:15 AM	How To: Airplane Camping & Cooking	Richard Wellner	Forum Stage 4: PilotSmith	J-9	F
10:00 AM - 11:15 AM	Piston Engine Fuels	Jennifer Miller	Forum Stage 5: Scheme Designers	J-9	F
10:00 AM - 11:15 AM	The Savvy Borescope Initiative	Mike Busch	Forum Stage 6: EnerSys	J-9	F
10:00 AM - 11:15 AM	ForeFlight Fundamentals	ForeFlight	Forum Stage 7: ForeFlight	J-9	F
10:00 AM - 11:15 AM	Reno L-39C Race Jet 5 Speed Mods	Ed Noel	Forum Stage 8: GAMA	J-9	F
10:00 AM - 11:15 AM	Lean of Peak and Mixture Management	Martin Pauly	Forum Stage 9: SOFTIE PARACHUTES by Para-Phernalia Inc.	J-9	F
10:00 AM - 11:15 AM	Mastering the Tailwheel	Budd Davison	Forum Stage 10: Poly Fiber Inc.	K-9	F
10:00 AM - 11:15 AM	Flight-Test Engineering	Becca Aronoff	Forum Stage 11: DeltaHawk Engines	K-9	F
10:00 AM - 11:15 AM	Designing a Panel on Computer	Gene Velazquez	Workshop Classroom A	K-10	F
10:00 AM - 11:15 AM	Gweduck Amphibious Twin	Mark Mahnke	Workshop Classroom B	K-10	F
10:00 AM - 11:15 AM	Radial Engine Familiarization	Logan Simmons	Workshop Classroom C	K-10	F
10:00 AM - 11:15 AM	Forming Basics	Mark Kennison	Aeroplane Workshop	L-9	W

DAILY EVENTS

Sponsored by  **AIRCRAFT
WHEEL & BRAKE**
BY KAMAN

Cleveland
Wheels & Brakes

TIME	PRESENTATION	SPEAKER	LOCATION	MAP	TYPE
WEDNESDAY, JULY 24, 2024					
10:00 AM - 11:15 AM	Sport Aerobatics Intl. Stories	Lorrie Penner	International Aerobatic Club (IAC) Aerobatics Center	L-12	F
10:00 AM - 11:15 AM	Searching for Amelia Earhart	Dr. Leo Murphy	EAA Museum - Vette Theater	B-8	F
10:00 AM - 11:15 AM	The Aileron Patent Story	Russell Klingaman	EAA Museum - Hilton Theater	B-8	F
10:00 AM - 11:15 AM	Bomber Boys: Creating the Book	John Slemp	EAA Museum - Skyscape Theater	B-8	F
10:00 AM - 11:15 AM	Open-Source CNC	Mark Baenen	Homebuilders Hangar Supported by Aircraft Spruce & Specialty	K-9	F
10:00 AM - 11:15 AM	Homebuilts in Review		Homebuilts in Review	K-9	F
10:00 AM - 11:15 AM	Flying the Blue Quicksilver	Mike Ostrander	Ultralight Forums Tent	K-18	F
10:15 AM - 11:30 AM	Canadian Chapter Leaders Gathering	Phillip Johnson	EAA Canada	K-12	F
10:15 AM - 12:00 PM	Colorado Mountain Flying	Bill Standerfer	FAA Aviation Safety Center, Flight Service Station	J-11	F
10:30 AM - 11:00 AM	Catalyst Engine: Beechcraft Denali	Josh Hobson	GE Aerospace	K-14	F
10:30 AM - 11:15 AM	Improve Weather Services	Joshua Scheck	International Federal Pavilion	I-13	F
10:30 AM - 11:30 AM	Straighten Up & Fly Right	Greg Roark	Redbird Sim Lab	J-13	F
10:30 AM - 11:45 AM	Beyond Scientists and Astronauts	April Lanotte	EAA AeroEducate Forum Tent	I-10	F
10:45 AM - 12:00 PM	Vintage in Review	Ray Johnson	Rose Plaza Interview Circle	L-14	F
11:00 AM - 11:30 AM	Day in the Life of an Airline Pilot	F/O Justin Dahan	ALPA Booth 329	K-14	FE
11:00 AM - 11:30 AM	Introducing Airspace Insight	Iain Box	GE Aerospace	K-14	F
11:00 AM - 11:30 AM	Let Your Pilot Career Take Flight	Southwest Airlines	Southwest Airlines	I-10	F
11:00 AM - 11:45 AM	Play Scrabble With TNT	John and Martha King	NAFI Booth	J-14	F
11:00 AM - 12:00 PM	Grease Basics and Functions	Piotr Gawecki	AeroShell Booth 446/457	L-11	F
11:00 AM - 12:00 PM	Introduction to Kitfox Aircraft	John McBean	Rotax Aircraft Engines Booth	J-12	F
11:00 AM - 12:00 PM	Garmin X Embry-Riddle	Embry-Riddle Aeronautical University	Embry-Riddle Booth 49	J-10	F
11:00 AM - 12:00 PM	Cockpit Upgrades on a Budget	Garmin	Garmin Seminar Tent 2	K-13	F
11:00 AM - 12:00 PM	An In-Depth Look at GI 275	Garmin Aviation Team	Garmin Seminar Tent 1	K-13	F
11:00 AM - 12:00 PM	Plane Talk	Ryan Dembroski	Boeing Plaza	L-13	F
11:00 AM - 12:00 PM	WomenVenture Photo		Boeing Plaza	L-13	SE
11:00 AM - 12:00 PM	Tails핀	John Armbruster	EAA Warehouse	J-12	MG
11:00 AM - 12:00 PM	Fairchild Club Forum	Mike Kelly	Vintage Hangar	K-15	F
11:00 AM - 12:15 PM	ATC & You: In-Flight Emergencies	NATCA	NATCA Booth	J-10	F
11:30 AM - 12:00 PM	Landing an Aviation Scholarship	F/O Camila Turrieta	ALPA Booth 329	K-14	FE
11:30 AM - 12:00 PM	Personal Aviation in Canada	Mark van Berkel	EAA Canada	K-12	F
11:30 AM - 12:15 PM	TFRs: How to Avoid an Intercept	Lt. Col. Trevor "Boat" Boswell	International Federal Pavilion	I-13	F
11:30 AM - 12:30 PM	Reaching Optimal Engine Performance	Chuck Cook	Continental Aerospace Technologies	J-12	F
11:30 AM - 12:30 PM	Aeronautics in Your Classroom	Greg Roark	Redbird Sim Lab	J-13	F
11:30 AM - 12:30 PM	Dynon Certified for TC Aircraft	Dynon Staff	Dynon Tent	I-13	F
11:30 AM - 12:45 PM	MOSAIC (Learn to Fly)	EAA Govt Advocacy Team	EAA Learn to Fly Center	J-13	F
11:30 AM - 12:45 PM	Meet and Greet With Skip Stewart	William "Skip" Stewart	Hartzell Propeller 296-297	J-13	MG
11:30 AM - 12:45 PM	Chapter Donations: Taxes & Records	Patricia Arthur, Esq.	EAA Blue Barn Featuring EAA Chapters, EAA Young Eagles, and EAA Eagle Flights	J-9	F
11:30 AM - 12:45 PM	Aviators From the Past	Keith Clark	Forum Stage 1: WILCO	K-9	F
11:30 AM - 12:45 PM	Self-Fly Vacations	Clare McEwan	Forum Stage 2: Aero Hose Shop	K-9	F
11:30 AM - 12:45 PM	Lycoming Engine Installation	Judson Rupert	Forum Stage 3: Superflite	K-9	F
11:30 AM - 12:45 PM	Professional Logbook Tips	Eric Berman	Forum Stage 4: PilotSmith	J-9	F
11:30 AM - 12:45 PM	Electric Reality According to Dave	Dr. David Ullman	Forum Stage 5: Scheme Designers	J-9	F
11:30 AM - 12:45 PM	Which RV Is Right for Me?	Van's Aircraft	Forum Stage 6: EnerSys	J-9	F
11:30 AM - 12:45 PM	Commercial Space & Wingships	Burt Rutan	Forum Stage 7: ForeFlight	J-9	F
11:30 AM - 12:45 PM	NASA's Quest to End the Boom Ban	Peter Coen	Forum Stage 8: GAMA	J-9	F
11:30 AM - 12:45 PM	Zenith CH 6XX-Series: 40 Years	Sebastien Heintz	Forum Stage 9: SOFTIE PARACHUTES by Para-Phernalia Inc.	J-9	F
11:30 AM - 12:45 PM	Landing a Pitts and Loving It	Budd Davison	Forum Stage 10: Poly Fiber Inc.	K-9	F
11:30 AM - 12:45 PM	Backcountry Flying	Ramona Cox	Forum Stage 11: DeltaHawk Engines	K-9	F
11:30 AM - 12:45 PM	Advanced Composites: Carbon Fiber	Scott VanderVeen	Workshop Classroom A	K-10	W
11:30 AM - 12:45 PM	Franklin Engines and the FAA	Dale Still	Workshop Classroom B	K-10	F
11:30 AM - 12:45 PM	Electronic Ignition Basics	William Repucci	Workshop Classroom C	K-10	F
11:30 AM - 12:45 PM	English Wheel	Mark Kennison	Aeroplane Workshop	L-9	W
11:30 AM - 12:45 PM	Intermediate With Less Than 300 HP	Phillip Gragg	International Aerobatic Club (IAC) Aerobatics Center	L-12	F
11:30 AM - 12:45 PM	Estate Planning With a Purpose	Christopher Musha	EAA Museum - Vette Theater	B-8	F
11:30 AM - 12:45 PM	First Female 747 Pilot's Journey	Lynn Rippelmeyer	EAA Museum - Hilton Theater	B-8	F

TIME	PRESENTATION	SPEAKER	LOCATION	MAP	TYPE
WEDNESDAY, JULY 24, 2024					
11:30 AM - 12:45 PM	Air America: Covert Air Operations	Neil Hansen	EAA Museum - Skyscape Theater	B-8	F
11:30 AM - 12:45 PM	Butcher Bird 58 Percent	Chris Sims	Homebuilders Hangar Supported by Aircraft Spruce & Specialty	K-9	F
11:30 AM - 12:45 PM	STOL Across the U.S.: Tips & Tricks	Dr. Robert Jones	Ultralight Forums Tent	K-18	F
11:30 AM - 2:00 PM	Homebuilt Rotorcraft		Fun Fly Zone	K-20	SE
12:00 PM - 12:30 PM	Vantage12 Upgrade for Cirrus	Tom Harper	Avidyne Booth 3130A	I-12	F
12:00 PM - 12:30 PM	Pathways to the Airlines	F/O Mark Lockwood	ALPA Booth 329	K-14	FE
12:00 PM - 12:45 PM	AI in Aviation Explained	Dr. Piotr Diugiewicz	NAFI Booth	J-14	F
12:00 PM - 12:45 PM	Is it Ready to Cover or Not?	Lars Gleitsmann	Ultralight Workshop Tent	K-18	F
12:00 PM - 12:45 PM	Density Altitude	Tom Letts	AOPA Program Pavilion	L-11	F
12:00 PM - 12:45 PM	WomenVenture Power Lunch		Theater in the Woods Supported by M&M'S	K-15	SE
12:00 PM - 1:00 PM	Garmin Engine Monitor Solutions	Garmin	Garmin Seminar Tent 2	K-13	F
12:00 PM - 1:00 PM	GNS Transition: Find Your Next GPS	Garmin Aviation Team	Garmin Seminar Tent 1	K-13	F
12:00 PM - 1:00 PM	Plane Talk	Ryan Dembroski	Boeing Plaza	L-13	F
12:00 PM - 1:00 PM	The B-25 in the Backyard	Wally Soplata	EAA Warehouse	J-12	MG
12:00 PM - 1:00 PM	Select the Best Piston Engine Oil	Piotr Gawecki	AeroShell Booth 446/457	L-11	F
12:00 PM - 2:00 PM	Checkride Failure Trends	Sarah Rovner	FAA Aviation Safety Center, Flight Service Station	J-11	F
12:00 PM - 5:00 PM	Type Clubs	Charlie Waterhouse	Vintage Hangar	K-15	F
12:30 PM - 1:00 PM	Military Vets to Airline Jets	Air Line Pilots Association	ALPA Booth 329	K-14	FE
12:30 PM - 1:15 PM	SARSAT Saves & Stats	Allan Knox	International Federal Pavilion	I-13	F
12:30 PM - 1:45 PM	ATC & You: Real-World Lessons Ch 3	NATCA	NATCA Booth	J-10	F
12:45 PM - 2:00 PM	Transport Canada Update	Ryan Johnson	EAA Canada	K-12	F
1:00 PM - 1:30 PM	Avidyne IFD With iPad/ForeFlight	Randall Edwards	Avidyne Booth 3130A	I-12	F
1:00 PM - 1:30 PM	Let Your Pilot Career Take Flight	Southwest Airlines	Southwest Airlines	I-10	F
1:00 PM - 1:45 PM	Quality Flight Experience for Less	Jason Depew	NAFI Booth	J-14	F
1:00 PM - 1:45 PM	Thinking About the Unthinkable	Bruce Landsberg	AOPA Program Pavilion	L-11	F
1:00 PM - 1:45 PM	Is it Ready to Cover or Not?	Lars Gleitsmann	Ultralight Workshop Tent	K-18	F
1:00 PM - 2:00 PM	Your Next Autopilot: GFC 500/600	Garmin Aviation Team	Garmin Seminar Tent 1	K-13	F
1:00 PM - 2:00 PM	How to Plan and Shop for Avionics	Garmin	Garmin Seminar Tent 2	K-13	F
1:00 PM - 2:00 PM	The Wright Engineers	Brian Page	EAA Warehouse	J-12	MG
1:00 PM - 2:00 PM	Plane Talk	Ryan Dembroski	Boeing Plaza	L-13	F
1:00 PM - 2:00 PM	Best Piston Engine Oil (Spanish)	Nicolas Corti	AeroShell Booth 446/457	L-11	F
1:00 PM - 2:00 PM	ADVANCEDPANEL Ecosystem Expansion	AFS Staff	Dynon Tent	I-13	F
1:00 PM - 2:00 PM	GE Aerospace: CF34 Fan Maintenance	Jim Condon	GE Aerospace	K-14	F
1:00 PM - 2:15 PM	Kiddie Pedal Plane Parade		Celebration Way	H-13	SE
1:00 PM - 2:15 PM	Meet and Greet With Ken Rieder	Ken Rieder	Hartzell Propeller 296-297	J-13	MG
1:00 PM - 2:15 PM	Survivalist's Guide: Flight Review	Bill Janowicz	EAA Learn to Fly Center	J-13	F
1:00 PM - 2:15 PM	Thrive in Male-Dominated Workplaces	Lane Wallace	EAA WomenVenture Center	K-10	F
1:00 PM - 2:15 PM	Hosting a Youth Aviation Career Day	Sarah Pagano	EAA Blue Barn Featuring EAA Chapters, EAA Young Eagles, and EAA Eagle Flights	J-9	F
1:00 PM - 2:15 PM	75th Anniversary of the T-34 & T-28	Paul Walters	Warbirds in Review	L-7	F
1:00 PM - 2:15 PM	Sailplane+Motor=SuperSport Flying	Murry Rozansky	Forum Stage 1: WILCO	K-9	F
1:00 PM - 2:15 PM	Fly Yourself to Mexico	Rick Gardner	Forum Stage 2: Aero Hose Shop	K-9	F
1:00 PM - 2:15 PM	The Real Cost to Owning an Aircraft	Scott "Sky" Smith	Forum Stage 3: Superlite	K-9	F
1:00 PM - 2:15 PM	Oxygen Maker Install & Use	Jim Ruttler	Forum Stage 4: PilotSmith	J-9	F
1:00 PM - 2:15 PM	I Need to Paint My Plane, Now What?	Craig Barnett	Forum Stage 5: Scheme Designers	J-9	F
1:00 PM - 2:15 PM	Transition From Piston to Turbine	Kristy Bolingbroke	Forum Stage 6: EnerSys	J-9	F
1:00 PM - 2:15 PM	ForeFlight Power Users	ForeFlight	Forum Stage 7: ForeFlight	J-9	F
1:00 PM - 2:15 PM	Quantifying Your Weather Risks	Dr. Scott Dennstaedt	Forum Stage 8: GAMA	J-9	F
1:00 PM - 2:15 PM	Future of Rutan Designs Symposium	Ryszard Zadow	Forum Stage 9: SOFTIE PARACHUTES by Para-Pernalia Inc.	J-9	F
1:00 PM - 2:15 PM	Fabric Covering 101	EAA SportAir	Forum Stage 10: Poly Fiber Inc.	K-9	W
1:00 PM - 2:15 PM	Flying Clubs: Getting Started	Timm Bogenhagen	Forum Stage 11: DeltaHawk Engines	K-9	F
1:00 PM - 2:15 PM	Sheet Metal 101	EAA SportAir Sheet Metal	Sheet Metal Workshop Presented by Aircraft Spruce & Specialty	J-10	W
1:00 PM - 2:15 PM	Composite 101	EAA SportAir Composites	Workshop Classroom A	K-10	W
1:00 PM - 2:15 PM	Wood Construction 101	EAA SportAir Wood	Wood Workshop	K-10	W
1:00 PM - 2:15 PM	PPG PRC/ProSeal Sealants 101	Ward LaPaglia	Workshop Classroom B	K-10	W
1:00 PM - 2:15 PM	Gas Welding 101	EAA SportAir Gas Welding	Gas Welding Workshop	K-10	W

DAILY EVENTS

Sponsored by  **AIRCRAFT
WHEEL & BRAKE**
BY KAMAN

Cleveland
Wheels & Brakes

TIME	PRESENTATION	SPEAKER	LOCATION	MAP	TYPE
WEDNESDAY, JULY 24, 2024					
1:00 PM - 2:15 PM	Interiors in Production Aircraft	Dennis Wolter	Workshop Classroom C	K-10	F
1:00 PM - 2:15 PM	Power Hammer	Mark Kennison	Aeroplane Workshop	L-9	W
1:00 PM - 2:15 PM	Building and Flying an RV-14	Steve Thorne	International Aerobatic Club (IAC) Aerobatics Center	L-12	F
1:00 PM - 2:15 PM	Spy Pilot	Gary Powers Jr.	EAA Museum - Vette Theater	B-8	F
1:00 PM - 2:15 PM	Accident Prevention and Recovery	Susan Stark Christianson	EAA Museum - Hilton Theater	B-8	F
1:00 PM - 2:15 PM	The Tuskegee Airmen	Brian Smith	EAA Museum - Skyscape Theater	B-8	FE
1:00 PM - 2:15 PM	Open-Source Avionics: DIY	Peter Nunn	Homebuilders Hangar Supported by Aircraft Spruce & Specialty	K-9	F
1:00 PM - 2:15 PM	Homebuilts in Review		Homebuilts in Review	K-9	F
1:00 PM - 2:15 PM	Airport Operations and Ultralights	Lily Johnson	Ultralight Forums Tent	K-18	F
1:00 PM - 2:30 PM	Vintage Children's Workshop	AC & Sue Hutson	Charles W. Harris Youth Aviation Center	L-15	W
1:00 PM - 3:00 PM	Reassembly of a Lycoming Engine	Michael Damiani	Lycoming Engines Booth	J-12	D
1:00 PM - 4:00 PM	TIG Welding 101	EAA SportAir TIG Welding	TIG Welding Workshop Presented by Lincoln Electric	K-10	W
1:15 PM - 2:00 PM	Empowering Pilots With Data	Johnathan Morrell	GE Aerospace	K-14	F
1:30 PM - 2:15 PM	Evolution of Drones and You	Paul Bryan	International Federal Pavilion	I-13	F
1:30 PM - 2:30 PM	Fun and Challenges of Seaplanes	Steve Guetter	EAA Seaplane Base Presented by Wipaire	Seaplane Base	F
2:00 PM - 2:30 PM	GNS-to-IFD in Experimental Aircraft	Tom Harper	Avidyne Booth 3130A	I-12	F
2:00 PM - 2:45 PM	Keep Your Medical/Pilot Certificate	Jeremy Browner	ADPA Program Pavilion	L-11	F
2:00 PM - 3:00 PM	Rules, Rules, Rules	Greg Roark	Redbird Sim Lab	J-13	F
2:00 PM - 3:00 PM	Building Your Experimental Panel	Garmin	Garmin Seminar Tent 2	K-13	F
2:00 PM - 3:00 PM	Choosing a Garmin PFD/MFD	Garmin Aviation Team	Garmin Seminar Tent 1	K-13	F
2:00 PM - 3:00 PM	Miss Blue	Pam Ward	EAA Warehouse	J-12	MG
2:00 PM - 3:15 PM	De-Icing Knowledge Test	Walter Randa	EAA Canada	K-12	F
2:00 PM - 4:00 PM	Straight Talk About Aviation Safety	John and Martha King	FAA Aviation Safety Center, Flight Service Station	J-11	F
2:15 PM - 6:00 PM	Wednesday Air Show	EAA	Air Show	M-13	A
2:30 PM - 3:15 PM	Auto Ground Collision Avoidance	To Be Announced	International Federal Pavilion	I-13	F
2:30 PM - 3:45 PM	Supersonic Success	Tammy Barlette	EAA WomenVenture Center	K-10	F
2:30 PM - 3:45 PM	Pilot Hiring Forum	United Airlines	Forum Stage 1: WILCO	K-9	F
2:30 PM - 3:45 PM	Navigating the Skies With iFly	Walter Boyd	Forum Stage 2: Aero Hose Shop	K-9	F
2:30 PM - 3:45 PM	NASA: Air Taxi and Drone Revolution	Devin Boyle	Forum Stage 3: Superflite	K-9	F
2:30 PM - 3:45 PM	Checklists: So Basic Yet So Misused	Philip Mandel	Forum Stage 4: Pilotsmith	J-9	F
2:30 PM - 3:45 PM	An ATC View of Engine Failures	Dean Brown	Forum Stage 5: Scheme Designers	J-9	F
2:30 PM - 3:45 PM	IFR: Mastering GPS Procedures	Gary Reeves	Forum Stage 6: EnerSys	J-9	F
2:30 PM - 3:45 PM	Prebuy Examinations	Mike Busch	Forum Stage 7: ForeFlight	J-9	F
2:30 PM - 3:45 PM	Stick-N-Rudder Flying Skills	Gordon Penner	Forum Stage 8: GAMA	J-9	F
2:30 PM - 3:45 PM	Painting Your Airplane	Jonathan McCormick	Forum Stage 9: SOFTIE PARACHUTES by Para-Phernalia Inc.	J-9	F
2:30 PM - 3:45 PM	So You Want to Work With Drones?	Zipline	Forum Stage 10: Poly Fiber Inc.	K-9	F
2:30 PM - 3:45 PM	Volunteer Flying: Giving Hope	Scott Ashton	Forum Stage 11: DeltaHawk Engines	K-9	F
2:30 PM - 3:45 PM	Oratex6000 Used Correctly	Lars Gleitsmann	Workshop Classroom A	K-10	W
2:30 PM - 3:45 PM	Valve Lapping in Place	David Pasquale	Workshop Classroom B	K-10	F
2:30 PM - 3:45 PM	Gas Welding Aluminum	EAA SportAir Gas Welding	Gas Welding Workshop	K-10	W
2:30 PM - 3:45 PM	Stadia Altimeters: Better Landings	Sean Sherman	Workshop Classroom C	K-10	F
2:30 PM - 3:45 PM	Advanced Forming	Mark Kennison	Aeroplane Workshop	L-9	W
2:30 PM - 3:45 PM	War and Love Stories From the POWs	Leon "Lee" Ellis	EAA Museum - Vette Theater	B-8	F
2:30 PM - 3:45 PM	Flying at Sea: The RNAS in WWI	Kip Lankenau	EAA Museum - Hilton Theater	B-8	F
2:30 PM - 3:45 PM	Silver Wings & Civil Rights	Jon Anderson	EAA Museum - Skyscape Theater	B-8	M
2:30 PM - 3:45 PM	Voyager Presentation	Burt Rutan	EAA Museum - SpaceShipOne/Voyager	B-8	F
2:30 PM - 3:45 PM	MOSAIC for Private & Sport Pilots	Charlie Becker	Homebuilders Hangar Supported by Aircraft Spruce & Specialty	K-9	F
2:30 PM - 3:45 PM	Rotax 2-Stroke Upkeep	Brett Lawton	Ultralight Forums Tent	K-18	F
3:00 PM - 3:45 PM	Escrow and Title Companies	Christina Hancock	ADPA Program Pavilion	L-11	F
3:00 PM - 4:00 PM	Life Takes Wings and More	Lynn Rippelmeyer	EAA Warehouse	J-12	MG
3:00 PM - 4:00 PM	AAM: Challenges and Innovations	Dr. Kyle Collins	Embry-Riddle Booth 49	J-10	F
3:15 PM - 4:00 PM	eAPIS and CANPASS: How to File	Jim Bell	EAA Canada	K-12	F
3:30 PM - 4:15 PM	Flying to the Bahamas	To Be Announced	International Federal Pavilion	I-13	F

TIME	PRESENTATION	SPEAKER	LOCATION	MAP	TYPE
WEDNESDAY, JULY 24, 2024					
4:00 PM - 5:00 PM	True North	Darren Pleasance	EAA Wearhouse	J-12	MG
4:00 PM - 5:15 PM	Women in Advanced Air Mobility	Kendal Prosack	EAA WomenVenture Center	K-10	F
4:00 PM - 5:15 PM	Understanding Aerodynamics With CFD	Jac van Egmond	Forum Stage 2: Aero Hose Shop	K-9	F
4:00 PM - 5:15 PM	Pilot Intro: Falken FlightView EFIS	Steven Sokol	Forum Stage 4: Pilotsmith	J-9	F
4:00 PM - 5:15 PM	The Wonderful Warthog, Part 3	Lindsay M. "Mad" Johnson	Forum Stage 7: ForeFlight	J-9	F
4:00 PM - 5:15 PM	CISM in Aviation: Why We Need It	James Woodke	Workshop Classroom A	K-10	F
4:00 PM - 5:15 PM	Never Rib Stitch or Pop Rivet Again	Siegfried Lanitz	Workshop Classroom B	K-10	F
4:00 PM - 5:15 PM	Piper Cub Forum	Clyde Smith	Workshop Classroom C	K-10	F
4:00 PM - 6:00 PM	Vertical Aviation With Superior ADM	James Viola	FAA Aviation Safety Center, Flight Service Station	J-11	F
5:00 PM - 6:00 PM	Leading With Honor and More	Leon "Lee" Ellis	EAA Wearhouse	J-12	MG
5:00 PM - 6:00 PM	VAA Annual Meeting	Susan Dusenbury	Charles W. Harris Youth Aviation Center	L-15	SE
5:30 PM - 6:45 PM	Piper Cub Forum	John Hofmann	Workshop Classroom C	K-10	F
6:00 PM - 8:00 PM	Balloon Static Inflation		Fun Fly Zone	K-20	SE
6:30 PM - 7:30 PM	Ultralights and Lightplanes		Fun Fly Zone	K-20	SE
6:30 PM - 8:00 PM	Women in the Vertical Lift Industry	Heidi McBride	Theater in the Woods Supported by M&M'S	K-15	F
7:30 PM - 8:00 PM	Powered Parachutes		Fun Fly Zone	K-20	SE
8:00 PM - 10:00 PM	Wednesday Night Air Show	EAA	Air Show	M-13	A
8:30 PM - 10:45 PM	Fire Birds		Fly-In Theater Presented by Lycoming	E-13	M
THURSDAY, JULY 25, 2024					
7:00 AM - 7:45 AM	Fellowship of the Wing		Chapel and Compass Hill	E-8	CS
7:00 AM - 9:00 AM	Powered Parachutes		Fun Fly Zone	K-20	SE
7:00 AM - 9:00 AM	Balloon Static Inflation		Fun Fly Zone	K-20	SE
8:00 AM - 9:00 AM	Pilot Training With GFC 500X	Garmin	Garmin Seminar Tent 2	K-13	F
8:00 AM - 9:00 AM	Configuring G3X Touch	Garmin Aviation Team	Garmin Seminar Tent 1	K-13	F
8:00 AM - 9:00 AM	Aeronca Flying Collection	Lt. Col. Craig MacVeigh	Vintage Hangar	K-15	F
8:00 AM - 9:15 AM	ATC & You: Speaking With Confidence	NATCA	NATCA Booth	J-10	F
8:00 AM - 10:15 AM	General Aviation Awards	Adam Magee	FAA Aviation Safety Center, Flight Service Station	J-11	F
8:00 AM - 12:00 PM	Metal Shaping Demonstration	Dave Wenglarz	Vintage Hangar	K-15	D
8:30 AM - 9:30 AM	Can I Run My Engine Lean of Peak?	Chuck Cook	Continental Aerospace Technologies	J-12	F
8:30 AM - 9:45 AM	Creating a Youthful EAA Chapter	Karen Hughes	EAA Blue Barn Featuring EAA Chapters, EAA Young Eagles, and EAA Eagle Flights	J-9	F
8:30 AM - 9:45 AM	Introduction to Soaring Flight	Scott Manley	EAA Learn to Fly Center	J-13	F
8:30 AM - 9:45 AM	Cessna 305 Bird Dog, How To	Michael Weinfurter	Forum Stage 1: WILCO	K-9	F
8:30 AM - 9:45 AM	Swift Fuels Unleaded Avgas	Chris D'Acosta	Forum Stage 2: Aero Hose Shop	K-9	F
8:30 AM - 9:45 AM	MiG-23, MiG-29, and Su-27 in Detail	Thomas Woodford	Forum Stage 3: Superflite	K-9	F
8:30 AM - 9:45 AM	Intro to FlyQ EFB	Robert McGuire	Forum Stage 4: Pilotsmith	J-9	F
8:30 AM - 9:45 AM	Aircraft Transactions Made Easy	Brian Bronson	Forum Stage 5: Scheme Designers	J-9	F
8:30 AM - 9:45 AM	Aviation Real Estate	Melanie Riddick	Forum Stage 6: EnerSys	J-9	F
8:30 AM - 9:45 AM	Density Altitude: What's the Deal?	Tom Letts	Forum Stage 7: ForeFlight	J-9	F
8:30 AM - 9:45 AM	NASA's Aviary Takes Flight	Carl Recine	Forum Stage 8: GAMA	J-9	F
8:30 AM - 9:45 AM	Flying Bonanzas & Barons	Michael Kaufman	Forum Stage 9: SOFTIE PARACHUTES by Para-Phernalia Inc.	J-9	F
8:30 AM - 9:45 AM	Fabric Covering 101	EAA SportAir	Forum Stage 10: Poly Fiber Inc.	K-9	W
8:30 AM - 9:45 AM	Mountain Flying Techniques & Tips	Lori MacNichol	Forum Stage 11: DeltaHawk Engines	K-9	F
8:30 AM - 9:45 AM	Sheet Metal 101	EAA SportAir Sheet Metal	Sheet Metal Workshop Presented by Aircraft Spruce & Specialty	J-10	W
8:30 AM - 9:45 AM	Composite 101	EAA SportAir Composites	Workshop Classroom A	K-10	W
8:30 AM - 9:45 AM	Wood Construction 101	EAA SportAir Wood	Wood Workshop	K-10	W
8:30 AM - 9:45 AM	Do-It-Yourself Filter Analysis	Ryan Stark	Workshop Classroom B	K-10	F
8:30 AM - 9:45 AM	Gas Welding 101	EAA SportAir Gas Welding	Gas Welding Workshop	K-10	W
8:30 AM - 9:45 AM	Weather or Not to Fly	Jenna Williamson	Workshop Classroom C	K-10	F
8:30 AM - 9:45 AM	Upset Recoveries: How and Why	Mike Kloch	International Aerobatic Club (IAC) Aerobatics Center	L-12	F
8:30 AM - 9:45 AM	Corvair Flight Engines	William Wynne	Homebuilders Hangar Supported by Aircraft Spruce & Specialty	K-9	F
8:30 AM - 12:00 PM	TIG Welding 101	EAA SportAir TIG Welding	TIG Welding Workshop Presented by Lincoln Electric	K-10	W
8:30 AM - 2:30 PM	Player Special Restoration		Aeroplane Workshop	L-9	D
8:30 AM - 2:30 PM	Fabric Covering Demonstration		Aeroplane Workshop	L-9	D

DAILY EVENTS

Sponsored by  **AIRCRAFT
WHEEL & BRAKE**
BY KAMAN

Cleveland
Wheels & Brakes

TIME	PRESENTATION	SPEAKER	LOCATION	MAP	TYPE
THURSDAY, JULY 25, 2024					
8:30 AM - 2:30 PM	Cozy Aircraft Build		Aeroplane Workshop	L-9	D
8:30 AM - 2:30 PM	Homebuilders Workshop Acro/Sonex	Aeroplane Workshop Volunteers	Aeroplane Workshop	L-9	D
8:30 AM - 3:45 PM	Zenith Kit Assembly Demonstration		Aeroplane Workshop	L-9	D
8:45 AM - 11:00 AM	On the Grounds & Up	Jerry Burke	EAA Wearhouse	J-12	MG
9:00 AM - 9:30 AM	3D	Mark Kennison	Aeroplane Workshop	L-9	W
9:00 AM - 9:45 AM	Rotax 503 Teardown and Assembly	Jeff Howell	Ultralight Workshop Tent	K-18	F
9:00 AM - 10:00 AM	GFC 500X Installation Basics	Garmin Aviation Team	Garmin Seminar Tent 1	K-13	F
9:00 AM - 10:00 AM	Get Started With Garmin Avionics	Garmin	Garmin Seminar Tent 2	K-13	F
9:00 AM - 10:00 AM	Wings of Gold	Beverly Weintraub	EAA Wearhouse	J-12	MG
9:00 AM - 10:00 AM	Plane Talk	Ryan Dembroski	Boeing Plaza	L-13	F
9:00 AM - 10:00 AM	Intro to Rotax Aircraft Engines	Lauren Burton	Rotax Aircraft Engines Booth	J-12	F
9:00 AM - 10:00 AM	Aviatrix and The Firsts	Mary Shipko	EAA WomenVenture Center	K-10	MG
9:00 AM - 10:00 AM	Design, Build, Fly: Airplane Sims	Embry-Riddle Aeronautical University	Embry-Riddle Booth 49	J-10	F
9:00 AM - 10:00 AM	International Cessna 195 Club Forum	Larry Nelson	Vintage Hangar	K-15	F
9:00 AM - 10:15 AM	Building an AirCam & RV-10	Jim Moshonsky	EAA Canada	K-12	F
9:00 AM - 11:30 AM	Ultralights and Lightplanes		Fun Fly Zone	K-20	SE
9:00 AM - 12:00 PM	Paul's Vintage Workshop	Jim Hamilton	Vintage Hangar	K-15	W
9:15 AM - 9:30 AM	GE Aerospace Careers Open House	Talent Acquisition - GE Aerospace	GE Aerospace	K-14	MG
9:30 AM - 10:15 AM	Fly Quietly	Cliff Chetwin	International Federal Pavilion	I-13	F
9:30 AM - 10:30 AM	Rules, Rules, Rules	Greg Roark	Redbird Sim Lab	J-13	F
9:30 AM - 10:30 AM	GE Aerospace: CF34 Fan Maintenance	Jim Condon	GE Aerospace	K-14	F
9:30 AM - 10:45 AM	ATC & You: SIDS/STARS	NATCA	NATCA Booth	J-10	F
9:30 AM - 11:30 AM	Lycoming Engine Ignition System	Michael Damiani	Lycoming Engines Booth	J-12	D
10:00 AM - 10:30 AM	Avidyne IFD With Portable Devices	Randall Edwards	Avidyne Booth 3130A	I-12	F
10:00 AM - 10:45 AM	10 Ways to Make Flying 10x Safer	Philip Mandel	NAFI Booth	J-14	F
10:00 AM - 10:45 AM	Straight Talk About Aviation Safety	John and Martha King	AOPA Program Pavilion	L-11	F
10:00 AM - 10:45 AM	Rotax 503 Teardown and Assembly	Jeff Howell	Ultralight Workshop Tent	K-18	F
10:00 AM - 11:00 AM	Choosing an Aviation Mechanic	Bill Ross	Superior Air Parts Booth	I-13	F
10:00 AM - 11:00 AM	Garmin Pilot App Tips & Tricks	Garmin	Garmin Seminar Tent 2	K-13	F
10:00 AM - 11:00 AM	VNAV with GTN Xi & GFC 500 Training	Garmin Aviation Team	Garmin Seminar Tent 1	K-13	F
10:00 AM - 11:00 AM	Continental's Guide to Reaching TBO	Tim Owen	Continental Aerospace Technologies	J-12	F
10:00 AM - 11:00 AM	Plane Talk	Ryan Dembroski	Boeing Plaza	L-13	F
10:00 AM - 11:00 AM	Final Mission	Chris Henry	EAA Wearhouse	J-12	MG
10:00 AM - 11:00 AM	Cleveland Wheel & Brake Maintenance	Vern Rodgers	AeroShell Booth 446/457	L-11	F
10:00 AM - 11:00 AM	Dynon Systems for Experimentals	Dynon Staff	Dynon Tent	I-13	F
10:00 AM - 11:00 AM	Halfway Around the World in 40 Days	Kathrin Kaiser	EAA WomenVenture Center	K-10	MG
10:00 AM - 11:00 AM	Pilot Show-and-Tell	AC & Sue Hutson	Charles W. Harris Youth Aviation Center	L-15	F
10:00 AM - 11:00 AM	American Waco Club Forum	Paul Carmichael	Vintage Hangar	K-15	F
10:00 AM - 11:15 AM	Douglas C-47 Skytrain	Eric Zipkin	Warbirds in Review	L-7	F
10:00 AM - 11:15 AM	Recipe for Aviation Summer Camp	Terry Cusack	EAA Blue Barn Featuring EAA Chapters, EAA Young Eagles, and EAA Eagle Flights	J-9	F
10:00 AM - 11:15 AM	Hartzell Composite Propellers 101	Aaron "Opie" Perry	Hartzell Propeller 296-297	J-13	F
10:00 AM - 11:15 AM	Pass Your Checkride (The Flight)	Larry Bothe	EAA Learn to Fly Center	J-13	F
10:00 AM - 11:15 AM	AAM: Challenges and Innovations	Dr. Kyle Collins	Forum Stage 1: WILCO	K-9	F
10:00 AM - 11:15 AM	U.S. Defense During the Cold War	John Bronson	Forum Stage 2: Aero Hose Shop	K-9	F
10:00 AM - 11:15 AM	Burning Man: 88NV Dust-to-Dust	Josh Bergmann	Forum Stage 3: Superflite	K-9	F
10:00 AM - 11:15 AM	Pilot Hiring Forum	United Airlines	Forum Stage 4: Pilotsmith	J-9	F
10:00 AM - 11:15 AM	Engine Cooling Basics	Sonja Englert	Forum Stage 5: Scheme Designers	J-9	F
10:00 AM - 11:15 AM	Minimally Invasive Maintenance	Mike Busch	Forum Stage 6: EnerSys	J-9	F
10:00 AM - 11:15 AM	What Is New in ForeFlight	ForeFlight	Forum Stage 7: ForeFlight	J-9	F
10:00 AM - 11:15 AM	Buying Your First Seaplane	Wipaire	Forum Stage 8: GAMA	J-9	F
10:00 AM - 11:15 AM	Zenith STOL: Form Follows Function	Sebastien Heintz	Forum Stage 9: SOFTIE PARACHUTES by Para-Phernalia Inc.	J-9	F
10:00 AM - 11:15 AM	Lycoming Engines EIS Overview	Judson Rupert	Forum Stage 10: Poly Fiber Inc.	K-9	F
10:00 AM - 11:15 AM	Rutan Aircraft Flying Experience	Ryszard Zadow	Forum Stage 11: DeltaHawk Engines	K-9	F
10:00 AM - 11:15 AM	Aging Aircraft Issues	Dennis Wolter	Workshop Classroom A	K-10	F
10:00 AM - 11:15 AM	How to Shine: Part 1	Radara Elkins	Workshop Classroom B	K-10	F
10:00 AM - 11:15 AM	Light Sport Repairman Rating	Brian Carpenter	Workshop Classroom C	K-10	F
10:00 AM - 11:15 AM	Forming Basics	Mark Kennison	Aeroplane Workshop	L-9	W

TIME	PRESENTATION	SPEAKER	LOCATION	MAP	TYPE
THURSDAY, JULY 25, 2024					
10:00 AM - 11:15 AM	How the Sukhoi Was Born	Brooks Mershon	International Aerobatic Club (IAC) Aerobatics Center	L-12	F
10:00 AM - 11:15 AM	Icing Encounters Survival Guide	Parvez Dara	EAA Museum - Hilton Theater	B-8	F
10:00 AM - 11:15 AM	On the Nuclear Bull's-Eye	Carlton Stidsen	EAA Museum - Skyscape Theater	B-8	F
10:00 AM - 11:15 AM	Building an RV-14 as a Couple	Ken & Melissa VeArd	Homebuilders Hangar Supported by Aircraft Spruce & Specialty	K-9	F
10:00 AM - 11:15 AM	Homebuilts in Review		Homebuilts in Review	K-9	F
10:00 AM - 11:15 AM	MOSAIC: Sport Pilot 2.0	Timm Bogenhagen	Ultralight Forums Tent	K-18	F
10:15 AM - 11:30 AM	COPA Meet and Greet With a Snowbird		EAA Canada	K-12	F
10:15 AM - 12:00 PM	Do You Have Operational Discipline?	Greg Feith	FAA Aviation Safety Center, Flight Service Station	J-11	F
10:30 AM - 11:00 AM	Introducing Airspace Insight	Iain Box	GE Aerospace	K-14	F
10:30 AM - 11:00 AM	AirVenture's Titan Aerobatic Team	Capt. Jimmy Fordham	ALPA Booth 329	K-14	MG
10:30 AM - 11:15 AM	Auto Ground Collision Avoidance	To Be Announced	International Federal Pavilion	I-13	F
10:30 AM - 11:30 AM	Wow, It's REALLY Windy	Greg Roark	Redbird Sim Lab	J-13	F
10:30 AM - 11:45 AM	Explore Avionics Careers	Nick Brown	EAA AeroEducate Forum Tent	I-10	F
10:45 AM - 12:00 PM	Vintage in Review	Ray Johnson	Rose Plaza Interview Circle	L-14	F
11:00 AM - 11:30 AM	Day in the Life of an Airline Pilot	F/O Justin Dahan	ALPA Booth 329	K-14	FE
11:00 AM - 11:30 AM	First U.S. Jet Engine Comes to Life	Nick Hurm	GE Aerospace	K-14	F
11:00 AM - 11:30 AM	Let Your Pilot Career Take Flight	Southwest Airlines	Southwest Airlines	I-10	F
11:00 AM - 11:45 AM	Schematics to Scenarios	John Boos	NAFI Booth	J-14	F
11:00 AM - 11:45 AM	Pilot Town Hall	Mark Baker	AOPA Program Pavilion	L-11	F
11:00 AM - 12:00 PM	Cockpit Upgrades on a Budget	Garmin	Garmin Seminar Tent 2	K-13	F
11:00 AM - 12:00 PM	An In-Depth Look at GI 275	Garmin Aviation Team	Garmin Seminar Tent 1	K-13	F
11:00 AM - 12:00 PM	Plane Talk	Ryan Dembroski	Boeing Plaza	L-13	F
11:00 AM - 12:00 PM	Turret Tales	Judie Ohm	EAA Wearhouse	J-12	MG
11:00 AM - 12:00 PM	Nerves of Steel and More	Tammie Jo Shults	EAA WomenVenture Center	K-10	MG
11:00 AM - 12:00 PM	Flying a Modern Wright B Flyer	Jeff Stands	Vintage Hangar	K-15	F
11:00 AM - 12:15 PM	ATC & You: Make the Most of VFR	NATCA	NATCA Booth	J-10	F
11:30 AM - 12:00 PM	Landing an Aviation Scholarship	F/O Camila Turrieta	ALPA Booth 329	K-14	FE
11:30 AM - 12:00 PM	MOSAIC LSA: Already in Canada?	Chris Horsten	EAA Canada	K-12	F
11:30 AM - 12:15 PM	Aircraft Ops Center Recruiting	Andy Reynaga	International Federal Pavilion	I-13	F
11:30 AM - 12:30 PM	A Pilot's Guide to Logbook Entries	Chuck Cook	Continental Aerospace Technologies	J-12	F
11:30 AM - 12:30 PM	CSN = Can't See Nothin'	Greg Roark	Redbird Sim Lab	J-13	F
11:30 AM - 12:30 PM	Advanced Systems for Experimentals	AFS Staff	Dynon Tent	I-13	F
11:30 AM - 12:45 PM	How to Use Flight Sims for Training	Josh Harnagel	EAA Learn to Fly Center	J-13	F
11:30 AM - 12:45 PM	501(c)(3) Status and Your Chapter	Patricia Arthur, Esq.	EAA Blue Barn Featuring EAA Chapters, EAA Young Eagles, and EAA Eagle Flights	J-9	F
11:30 AM - 12:45 PM	The Truth About Taildraggers	Murry Rozansky	Forum Stage 1: WILCO	K-9	F
11:30 AM - 12:45 PM	SureFly Electronic Ignition	Jason Hutchinson	Forum Stage 2: Aero Hose Shop	K-9	F
11:30 AM - 12:45 PM	Your Pilot Mindset	David Consbruck	Forum Stage 3: Superlite	K-9	F
11:30 AM - 12:45 PM	Fly Yourself to the Bahamas	Rick Gardner	Forum Stage 4: Pilotsmith	J-9	F
11:30 AM - 12:45 PM	Aviation Photography & You	David Powell	Forum Stage 5: Scheme Designers	J-9	F
11:30 AM - 12:45 PM	Flying to the Bahamas and Caribbean	Jim Parker	Forum Stage 6: EnerSys	J-9	F
11:30 AM - 12:45 PM	Burt's New Designs and His Heroes	Burt Rutan	Forum Stage 7: ForeFlight	J-9	F
11:30 AM - 12:45 PM	Will Your Engine Survive Unleaded?	George Braly	Forum Stage 8: GAMA	J-9	F
11:30 AM - 12:45 PM	How to Operate an Electric Aircraft	Miguel Marmol	Forum Stage 9: SOFTIE PARACHUTES by Para-Phernalia Inc.	J-9	F
11:30 AM - 12:45 PM	CBT in Ab Initio Flight Training	The Boeing Company	Forum Stage 10: Poly Fiber Inc.	K-9	F
11:30 AM - 12:45 PM	IFR Autopilot Pro Tips	Gary Reeves	Forum Stage 11: DeltaHawk Engines	K-9	F
11:30 AM - 12:45 PM	Fiberglass for RV	Scott VanderVeen	Workshop Classroom A	K-10	W
11:30 AM - 12:45 PM	Electronic Logbooks: Get Started	Eric Berman	Workshop Classroom B	K-10	F
11:30 AM - 12:45 PM	Small Airplanes at Large Airports	Martin Pauly	Workshop Classroom C	K-10	F
11:30 AM - 12:45 PM	Would You Enjoy Spins?	Michael Church	International Aerobatic Club (IAC) Aerobatics Center	L-12	F
11:30 AM - 12:45 PM	Meet the FAA Administrator	EAA Govt Advocacy Team	Theater in the Woods Supported by M&M'S	K-15	F
11:30 AM - 12:45 PM	Women Airline Pilots	Mary Shipko	EAA Museum - Hilton Theater	B-8	F
11:30 AM - 12:45 PM	Soviet Night Witches	Dr. Leo Murphy	EAA Museum - Skyscape Theater	B-8	F
11:30 AM - 12:45 PM	Flight Testing Basics	Gary Baker	Homebuilders Hangar Supported by Aircraft Spruce & Specialty	K-9	F

DAILY EVENTS

Sponsored by  **AIRCRAFT**
WHEEL & BRAKE
BY KAMAN

Cleveland
Wheels & Brakes

TIME	PRESENTATION	SPEAKER	LOCATION	MAP	TYPE
THURSDAY, JULY 25, 2024					
11:30 AM - 12:45 PM	Hot Air Balloons: Weather or Not	Rob Foxenberg	Ultralight Forums Tent	K-18	F
11:30 AM - 2:00 PM	Homebuilt Rotorcraft		Fun Fly Zone	K-20	SE
12:00 PM - 12:30 PM	Pathways to the Airlines	F/O Mark Lockwood	ALPA Booth 329	K-14	FE
12:00 PM - 12:45 PM	Let's Play: By the Rules	Robert Meder	NAFI Booth	J-14	F
12:00 PM - 12:45 PM	Painting Aluminum: Common Mistakes	Lars Gleitsmann	Ultralight Workshop Tent	K-18	F
12:00 PM - 12:45 PM	Aviatrix: Getting Into Aviation	Katrina Shull	AOPA Program Pavilion	L-11	F
12:00 PM - 1:00 PM	Garmin Engine Monitor Solutions	Garmin	Garmin Seminar Tent 2	K-13	F
12:00 PM - 1:00 PM	GNS Transition: Find Your Next GPS	Garmin Aviation Team	Garmin Seminar Tent 1	K-13	F
12:00 PM - 1:00 PM	Plane Talk	Ryan Dembroski	Boeing Plaza	L-13	F
12:00 PM - 1:00 PM	The Supersonic Bone	Kenneth Katz	EAA Warehouse	J-12	MG
12:00 PM - 1:00 PM	Understand Your Continental Engine	Tim Owen	AeroShell Booth 446/457	L-11	F
12:00 PM - 1:00 PM	Fly Girls Revolt	Eileen Bjorkman	EAA WomenVenture Center	K-10	MG
12:00 PM - 5:00 PM	Type Clubs	Charlie Waterhouse	Vintage Hangar	K-15	F
12:30 PM - 1:00 PM	Military Vets to Airline Jets	Air Line Pilots Association	ALPA Booth 329	K-14	FE
12:30 PM - 1:45 PM	ATC & You: Real-World Lessons Ch 1	NATCA	NATCA Booth	J-10	F
12:45 PM - 2:00 PM	Flying to and From Canada	Ian Brown	EAA Canada	K-12	F
1:00 PM - 1:30 PM	Hand Propping Demonstration	Dion Carr	Rose Plaza Interview Circle	L-14	D
1:00 PM - 1:30 PM	Let Your Pilot Career Take Flight	Southwest Airlines	Southwest Airlines	I-10	F
1:00 PM - 1:45 PM	Student Personalities	Rick Miller	NAFI Booth	J-14	F
1:00 PM - 1:45 PM	An Insider's View of NTSB and GA	Bruce Landsberg	AOPA Program Pavilion	L-11	F
1:00 PM - 1:45 PM	Painting Aluminum: Common Mistakes	Lars Gleitsmann	Ultralight Workshop Tent	K-18	F
1:00 PM - 2:00 PM	Your Next Autopilot: GFC 500/600	Garmin Aviation Team	Garmin Seminar Tent 1	K-13	F
1:00 PM - 2:00 PM	How to Plan and Shop for Avionics	Garmin	Garmin Seminar Tent 2	K-13	F
1:00 PM - 2:00 PM	Behind My Wings	BJ Elliott Prior	EAA Warehouse	J-12	MG
1:00 PM - 2:00 PM	Plane Talk	Ryan Dembroski	Boeing Plaza	L-13	F
1:00 PM - 2:00 PM	Rotax Injected Installation Info	Dean Vogel	Rotax Aircraft Engines Booth	J-12	F
1:00 PM - 2:00 PM	GE Aerospace: CF34 Fan Maintenance	Jim Condon	GE Aerospace	K-14	F
1:00 PM - 2:00 PM	Final Flight, Final Fight and More	Erin Miller	EAA WomenVenture Center	K-10	MG
1:00 PM - 2:00 PM	Design, Build, Fly: Airplane Sims	Embry-Riddle Aeronautical University	Embry-Riddle Booth 49	J-10	F
1:00 PM - 2:15 PM	Virtual Flight Instruction for Sims	Glenn Kowack	EAA Learn to Fly Center	J-13	F
1:00 PM - 2:15 PM	Meet and Greet With Rob Holland	Rob Holland	Hartzell Propeller 296-297	J-13	MG
1:00 PM - 2:15 PM	Transforming Youth Engagement	Jessica Schaefer	EAA Blue Barn Featuring EAA Chapters, EAA Young Eagles, and EAA Eagle Flights	J-9	F
1:00 PM - 2:15 PM	WWII Helldiver and P-47 Thunderbolt		Warbirds in Review	L-7	F
1:00 PM - 2:15 PM	AFWERX & Empowering Small Business	Karen Roth	Forum Stage 1: WILCO	K-9	F
1:00 PM - 2:15 PM	Keep Your Beech Flying Safely	American Bonanza Society	Forum Stage 2: Aero Hose Shop	K-9	F
1:00 PM - 2:15 PM	Drone Delivery: Facts vs. Fiction	Dallas Brooks	Forum Stage 3: Superflite	K-9	F
1:00 PM - 2:15 PM	Low Aspect Ratio Sport Aircraft	Barnaby Wainfan	Forum Stage 4: Pilotsmith	J-9	F
1:00 PM - 2:15 PM	I Need to Paint My Plane, Now What?	Craig Barnett	Forum Stage 5: Scheme Designers	J-9	F
1:00 PM - 2:15 PM	Engine Making Metal	Mike Busch	Forum Stage 6: EnerSys	J-9	F
1:00 PM - 2:15 PM	Jeppesen Advantage in ForeFlight	ForeFlight	Forum Stage 7: ForeFlight	J-9	F
1:00 PM - 2:15 PM	Navigating the Traffic Pattern	Tom Letts	Forum Stage 8: GAMA	J-9	F
1:00 PM - 2:15 PM	The Women of NASA's Quesst Mission	Dr. Melissa Carter	Forum Stage 9: SOFTIE PARACHUTES by Para-Phernalia Inc.	J-9	F
1:00 PM - 2:15 PM	Fabric Covering 101	EAA SportAir	Forum Stage 10: Poly Fiber Inc.	K-9	W
1:00 PM - 2:15 PM	MOSAIC	EAA Legal Advisory Council	Forum Stage 11: DeltaHawk Engines	K-9	F
1:00 PM - 2:15 PM	Sheet Metal 101	EAA SportAir Sheet Metal	Sheet Metal Workshop Presented by Aircraft Spruce & Specialty	J-10	W
1:00 PM - 2:15 PM	Composite 101	EAA SportAir Composites	Workshop Classroom A	K-10	W
1:00 PM - 2:15 PM	Wood Construction 101	EAA SportAir Wood	Wood Workshop	K-10	W
1:00 PM - 2:15 PM	Aircraft Tire Maintenance	Randy Hedrick	Workshop Classroom B	K-10	F
1:00 PM - 2:15 PM	Gas Welding 101	EAA SportAir Gas Welding	Gas Welding Workshop	K-10	W
1:00 PM - 2:15 PM	Precision Engine Balancing	Archie Frangoudis	Workshop Classroom C	K-10	F
1:00 PM - 2:15 PM	Power Hammer	Mark Kennison	Aeroplane Workshop	L-9	W
1:00 PM - 2:15 PM	Perspective From World Competition	Mike Lentz	International Aerobatic Club (IAC) Aerobatics Center	L-12	F
1:00 PM - 2:15 PM	Flying the Western Front	Kip Lankenau	EAA Museum - Hilton Theater	B-8	F
1:00 PM - 2:15 PM	Ramblings of a Bomber Pilot	Frank Allen	EAA Museum - Skyscape Theater	B-8	M
1:00 PM - 2:15 PM	Proper Composite Repair Techniques	D. Michael Bergen	Homebuilders Hangar Supported by Aircraft Spruce & Specialty	K-9	F

TIME	PRESENTATION	SPEAKER	LOCATION	MAP	TYPE
THURSDAY, JULY 25, 2024					
1:00 PM - 2:15 PM	Homebuilts in Review		Homebuilts in Review	K-9	F
1:00 PM - 2:15 PM	Planning for Emergencies	Dennis Demeter	Ultralight Forums Tent	K-18	F
1:00 PM - 2:30 PM	Vintage Children's Workshop	AC & Sue Hutson	Charles W. Harris Youth Aviation Center	L-15	W
1:00 PM - 3:00 PM	Reassembly of a Lycoming Engine	Michael Damiani	Lycoming Engines Booth	J-12	D
1:00 PM - 4:00 PM	Gas Metal Arc Welding (MIG Welding)	EAA SportAir TIG Welding	TIG Welding Workshop Presented by Lincoln Electric	K-10	W
1:30 PM - 2:15 PM	TFRs: How to Avoid an Intercept	Lt. Col. Trevor "Boat" Boswell	International Federal Pavilion	I-13	F
1:30 PM - 2:30 PM	Weather, Risk, and Gradient	Jeff Arnold	EAA Seaplane Base Presented by Wipaire	Seaplane Base	F
1:30 PM - 2:30 PM	Cable Splicing Demonstration	Dave Wenglarz	Vintage Hangar	K-15	D
2:00 PM - 2:45 PM	What Accidents Teach Us	Justin Moore	AOPA Program Pavilion	L-11	F
2:00 PM - 3:00 PM	Building Your Experimental Panel	Garmin	Garmin Seminar Tent 2	K-13	F
2:00 PM - 3:00 PM	Choosing a Garmin PFD/MFD	Garmin Aviation Team	Garmin Seminar Tent 1	K-13	F
2:00 PM - 3:00 PM	Up in the Air: A Pilot's Journey	Robert Fulton	EAA Wearhouse	J-12	MG
2:00 PM - 3:00 PM	The Women With Silver Wings	Katherine Landdeck	EAA WomenVenture Center	K-10	MG
2:00 PM - 3:15 PM	History of the Snowbirds	Jim Bell	EAA Canada	K-12	F
2:00 PM - 3:30 PM	How to Talk Pilot	Greg Roark	Redbird Sim Lab	J-13	F
2:00 PM - 4:00 PM	Letter From the FAA: What to Expect	Brian Khan	FAA Aviation Safety Center, Flight Service Station	J-11	F
2:15 PM - 6:00 PM	Thursday Air Show	EAA	Air Show	M-13	A
2:30 PM - 3:15 PM	Flying to the Bahamas	To Be Announced	International Federal Pavilion	I-13	F
2:30 PM - 3:45 PM	Educational Malpractice	S.V. (Steve) Dedmon	Forum Stage 1: WILCO	K-9	F
2:30 PM - 3:45 PM	Sweat the Showers not the Storms	Dr. Scott Dennstaedt	Forum Stage 2: Aero Hose Shop	K-9	F
2:30 PM - 3:45 PM	Flying to and Around Alaska	Anthony (Tony) Turinsky	Forum Stage 3: Superflite	K-9	F
2:30 PM - 3:45 PM	Taming the Graveyard Spiral III	John Crawford	Forum Stage 4: Pilotsmith	J-9	F
2:30 PM - 3:45 PM	VNAV & Visual Procedures	Gary Reeves	Forum Stage 5: Scheme Designers	J-9	F
2:30 PM - 3:45 PM	Homebuilt Spaceplanes: Let It Rock	John Bossard	Forum Stage 6: EnerSys	J-9	F
2:30 PM - 3:45 PM	B-17: The Final Mission	Chris Henry	Forum Stage 8: GAMA	J-9	F
2:30 PM - 3:45 PM	Buying Your First Airplane	David Fill	Forum Stage 9: SOFTIE PARACHUTES by Para-Phernalia Inc.	J-9	F
2:30 PM - 3:45 PM	When Are You Too Old to Fly?	Dr. Victor Vogel	Forum Stage 10: Poly Fiber Inc.	K-9	F
2:30 PM - 3:45 PM	African Air Safari: Fly Wild	Sjoerd Jan ter Welle	Forum Stage 11: DeltaHawk Engines	K-9	F
2:30 PM - 3:45 PM	Cessna 120/140 Maintenance Forum	George Adkins	Workshop Classroom A	K-10	F
2:30 PM - 3:45 PM	FAA Here to Help Avoid Turbulence	Tammy Flowe	Workshop Classroom B	K-10	F
2:30 PM - 3:45 PM	Gas Welding Aluminum	EAA SportAir Gas Welding	Gas Welding Workshop	K-10	W
2:30 PM - 3:45 PM	Advanced Forming	Mark Kennison	Aeroplane Workshop	L-9	W
2:30 PM - 3:45 PM	Thorp T-18	Lee Walton	Homebuilders Hangar Supported by Aircraft Spruce & Specialty	K-9	F
2:30 PM - 3:45 PM	Challengers Owner Forums	Robert Tchop	Ultralight Forums Tent	K-18	F
3:00 PM - 3:45 PM	How to Buy an Airplane	Brian Macbean	AOPA Program Pavilion	L-11	F
3:00 PM - 4:00 PM	EAA Canada Ice Cream Social		EAA Canada	K-12	SE
3:00 PM - 4:00 PM	Could I Be a Pilot?	Lauren Dalzell Settles	EAA Wearhouse	J-12	MG
3:00 PM - 4:00 PM	Life Takes Wings and More	Lynn Rippelmeyer	EAA WomenVenture Center	K-10	MG
3:30 PM - 4:15 PM	Heli Infrastructure & Accidents	Paul Causey	International Federal Pavilion	I-13	F
3:30 PM - 5:30 PM	Borescope Inspection Workshop	David Pasquale	Workshop Classroom C	K-10	W
4:00 PM - 4:45 PM	Maximum Fun, Minimum Cost	Cade Halle	AOPA Program Pavilion	L-11	F
4:00 PM - 5:00 PM	Leadership That Breaks Barriers	John Teichert	EAA Wearhouse	J-12	MG
4:00 PM - 5:00 PM	Jet Boss: Taking Risks	Laura Savino	EAA WomenVenture Center	K-10	MG
4:00 PM - 5:15 PM	Elevating Access to Bodily Autonomy	Mike Bonanza	Forum Stage 1: WILCO	K-9	F
4:00 PM - 5:15 PM	The Wonderful Warthog, Part 4	Michael Hare	Forum Stage 7: ForeFlight	J-9	F
4:00 PM - 5:15 PM	Freedom Aviation Network	Howard Kohnstamm	Workshop Classroom A	K-10	F
4:00 PM - 6:00 PM	CO! It's a Gas!	Mike Montefusco	FAA Aviation Safety Center, Flight Service Station	J-11	F
5:00 PM - 6:00 PM	The Last of the Wild Horses	Mark Phillips	EAA Wearhouse	J-12	MG
6:30 PM - 7:30 PM	Ultralights and Lightplanes		Fun Fly Zone	K-20	SE
7:00 PM - 9:00 PM	Musical Jam Session	Flying Musicians Association	Ultralight Forums Tent	K-18	SE
7:00 PM - 10:30 PM	Snowbirds Celebrate RCAF 100th		Theater in the Woods Supported by M&M'S	K-15	SE
7:30 PM - 8:00 PM	Powered Parachutes		Fun Fly Zone	K-20	SE
8:00 PM - 9:45 PM	Twilight Flight Fest		Fun Fly Zone	K-20	SE
8:30 PM - 9:30 PM	Balloon Glow		Fun Fly Zone	K-20	SE
8:30 PM - 10:45 PM	Captains of the Clouds		Fly-In Theater Presented by Lycoming	E-13	M

DAILY EVENTS

Sponsored by  **AIRCRAFT
WHEEL & BRAKE**
BY KAMAN

Cleveland
Wheels & Brakes

TIME	PRESENTATION	SPEAKER	LOCATION	MAP	TYPE
FRIDAY, JULY 26, 2024					
7:00 AM - 7:45 AM	Fellowship of the Wing		Chapel and Compass Hill	E-8	CS
7:00 AM - 9:00 AM	Powered Parachutes		Fun Fly Zone	K-20	SE
7:00 AM - 9:00 AM	Balloon Static Inflation		Fun Fly Zone	K-20	SE
8:00 AM - 8:45 AM	Your First Student	Aaron Dabney	NAFI Booth	J-14	F
8:00 AM - 9:00 AM	Veterans Breakfast		Partner Resource Center	H-11	SE
8:00 AM - 9:00 AM	Pilot Training With GFC 500X	Garmin	Garmin Seminar Tent 2	K-13	F
8:00 AM - 9:00 AM	G3X Touch Wiring & Data Buses	Garmin Aviation Team	Garmin Seminar Tent 1	K-13	F
8:00 AM - 9:15 AM	ATC & You: Mountains That Fool You	NATCA	NATCA Booth	J-10	F
8:00 AM - 10:15 AM	Canadian Breakfast		EAA Canada	K-12	MG
8:00 AM - 12:00 PM	Metal Shaping Demonstration	Dave Wenglarz	Vintage Hangar	K-15	D
8:30 AM - 9:30 AM	Can I Run My Engine Lean of Peak?	Chuck Cook	Continental Aerospace Technologies	J-12	F
8:30 AM - 9:30 AM	Lessons Learned CLE	EAA Legal Advisory Council	EAA Museum - Vette Theater	B-8	F
8:30 AM - 9:45 AM	Strategies for Chapter Leaders	Terry Cusack	EAA Blue Barn Featuring EAA Chapters, EAA Young Eagles, and EAA Eagle Flights	J-9	F
8:30 AM - 9:45 AM	Flying the Air Race Classic	Emmy Dillion	EAA WomenVenture Center	K-10	F
8:30 AM - 9:45 AM	Conquer the Checkride	Loren French	EAA Learn to Fly Center	J-13	F
8:30 AM - 9:45 AM	Accurate Pressure Derived AOA	Terry Lutz	Homebuilders Hangar Supported by Aircraft Spruce & Specialty	K-9	F
8:30 AM - 9:45 AM	Flying for Business 2024	Joe Quackenbush	Forum Stage 1: WILCO	K-9	F
8:30 AM - 9:45 AM	Lycoming Troubleshooting	Tyler Harbach	Forum Stage 2: Aero Hose Shop	K-9	F
8:30 AM - 9:45 AM	Crewed & Uncrewed Self-Reporting	Kenneth Kranz	Forum Stage 3: Superlite	K-9	F
8:30 AM - 9:45 AM	Aircraft Battery Airworthiness	Christopher Holder	Forum Stage 4: Pilotsmith	J-9	F
8:30 AM - 9:45 AM	Bob Hoover: A Pilot and a Teacher	Keith Clark	Forum Stage 5: Scheme Designers	J-9	F
8:30 AM - 9:45 AM	Leaning the Right Way	Mike Busch	Forum Stage 7: ForeFlight	J-9	F
8:30 AM - 9:45 AM	Adverse Wx: Perception vs. Reality	Dr. Ian Johnson	Forum Stage 8: GAMA	J-9	F
8:30 AM - 9:45 AM	Engine Failure IMC/Night: Now What?	Kevin Price	Forum Stage 9: SOFTIE PARACHUTES by Para-Phernalia Inc.	J-9	F
8:30 AM - 9:45 AM	Fabric Covering 101	EAA SportAir	Forum Stage 10: Poly Fiber Inc.	K-9	W
8:30 AM - 9:45 AM	Hangar Development on FAA Airports	Mark Godonis	Forum Stage 11: DeltaHawk Engines	K-9	F
8:30 AM - 9:45 AM	Sheet Metal 101	EAA SportAir Sheet Metal	Sheet Metal Workshop Presented by Aircraft Spruce & Specialty	J-10	W
8:30 AM - 9:45 AM	Composite 101	EAA SportAir Composites	Workshop Classroom A	K-10	W
8:30 AM - 9:45 AM	Wood Construction 101	EAA SportAir Wood	Wood Workshop	K-10	W
8:30 AM - 9:45 AM	Achieving Best Brake Performance	Ben McNamara	Workshop Classroom B	K-10	F
8:30 AM - 9:45 AM	Gas Welding 101	EAA SportAir Gas Welding	Gas Welding Workshop	K-10	W
8:30 AM - 9:45 AM	IAC Meeting	International Aerobatic Club	International Aerobatic Club (IAC) Aerobatics Center	L-12	SE
8:30 AM - 9:45 AM	Publish a Book Without Rip-Offs	David Powell	EAA Museum - Hilton Theater	B-8	F
8:30 AM - 10:15 AM	Aeromedical Updates	Dr. Susan Northrup	FAA Aviation Safety Center, Flight Service Station	J-11	F
8:30 AM - 12:00 PM	TIG Welding 101	EAA SportAir TIG Welding	TIG Welding Workshop Presented by Lincoln Electric	K-10	W
8:30 AM - 2:30 PM	Homebuilders Workshop Acro/Sonex	Aeroplane Workshop Volunteers	Aeroplane Workshop	L-9	D
8:30 AM - 2:30 PM	Cozy Aircraft Build		Aeroplane Workshop	L-9	D
8:30 AM - 2:30 PM	Fabric Covering Demonstration		Aeroplane Workshop	L-9	D
8:30 AM - 2:30 PM	Player Special Restoration		Aeroplane Workshop	L-9	D
8:30 AM - 3:45 PM	Zenith Kit Assembly Demonstration		Aeroplane Workshop	L-9	D
9:00 AM - 9:30 AM	3D	Mark Kennison	Aeroplane Workshop	L-9	W
9:00 AM - 9:45 AM	Staying Plugged Into Your Airport	Kyle Lewis	AOPA Program Pavilion	L-11	F
9:00 AM - 9:45 AM	Carburetor Rebuild and Plumbing		Ultralight Workshop Tent	K-18	F
9:00 AM - 9:45 AM	DPE Roundtable With the Masters	Karen Kalishek	NAFI Booth	J-14	F
9:00 AM - 9:45 AM	Intro to Rotax Aircraft Engines	Lauren Burton	Rotax Aircraft Engines Booth	J-12	F
9:00 AM - 10:00 AM	Turbine Oil Differences	Andy Mehring	AeroShell Booth 446/457	L-11	F
9:00 AM - 10:00 AM	Design, Build, Fly: Airplane Sims	Embry-Riddle Aeronautical University	Embry-Riddle Booth 49	J-10	F
9:00 AM - 10:00 AM	Finding Answers in Garmin Documents	Garmin Aviation Team	Garmin Seminar Tent 1	K-13	F
9:00 AM - 10:00 AM	GTN/GTN Xi Training: Tips & Tricks	Garmin	Garmin Seminar Tent 2	K-13	F
9:00 AM - 10:00 AM	Plane Talk	Ryan Dembroski	Boeing Plaza	L-13	F
9:00 AM - 10:00 AM	The Airline Transition Manual	Andrew Ross	EAA Wearhouse	J-12	MG
9:00 AM - 10:00 AM	Interstate Cadet & L-6	Andy Gelston	Vintage Hangar	K-15	F
9:00 AM - 10:15 AM	ANG: Beyond the Cockpit	Charles Earl Ellis	EAA AeroEducate Forum Tent	I-10	F
9:00 AM - 11:00 AM	On the Grounds & Up	Jerry Burke	EAA Wearhouse	J-12	MG

TIME	PRESENTATION	SPEAKER	LOCATION	MAP	TYPE
FRIDAY, JULY 26, 2024					
9:00 AM - 11:30 AM	Ultralights and Lightplanes		Fun Fly Zone	K-20	SE
9:00 AM - 12:00 PM	Paul's Vintage Workshop	Jim Hamilton	Vintage Hangar	K-15	W
9:15 AM - 9:30 AM	GE Aerospace Careers Open House	Talent Acquisition - GE Aerospace	GE Aerospace	K-14	MG
9:30 AM - 10:15 AM	National Aviation Meteorologist Ops	Wes Adkins	International Federal Pavilion	I-13	F
9:30 AM - 10:45 AM	ATC & You: Misleading Airports	NATCA	NATCA Booth	J-10	F
9:30 AM - 11:00 AM	Oh, the Places You'll Go!	Greg Roark	Redbird Sim Lab	J-13	F
9:30 AM - 11:15 AM	Attorney CLE	EAA Legal Advisory Council	EAA Museum - Vette Theater	B-8	F
9:30 AM - 11:30 AM	Lycoming Engine Valve Operation	Michael Damiani	Lycoming Engines Booth	J-12	D
10:00 AM - 10:30 AM	Hand Propping Demonstration	Dion Carr	Rose Plaza Interview Circle	L-14	D
10:00 AM - 10:30 AM	GNS-to-IFD Retrofit in Experimental	Mr. Will Rickert	Avidyne Booth 3130A	I-12	F
10:00 AM - 10:45 AM	Tips for a New CFI	Howard Greenberg	NAFI Booth	J-14	F
10:00 AM - 10:45 AM	Airport Boards and Commissions	Michael Ginter	AOPA Program Pavilion	L-11	F
10:00 AM - 10:45 AM	Carburetor Rebuild and Plumbing		Ultralight Workshop Tent	K-18	F
10:00 AM - 11:00 AM	Aircraft Engine Compression Testing	Bill Ross	Superior Air Parts Booth	I-13	F
10:00 AM - 11:00 AM	Getting Started With Garmin Pilot	Garmin	Garmin Seminar Tent 2	K-13	F
10:00 AM - 11:00 AM	Flying With G3X Touch Training	Garmin Aviation Team	Garmin Seminar Tent 1	K-13	F
10:00 AM - 11:00 AM	Continental's Guide to Reaching TBO	Tim Owen	Continental Aerospace Technologies	J-12	F
10:00 AM - 11:00 AM	Nerves of Steel and More	Tammie Jo Shults	EAA Wearhouse	J-12	MG
10:00 AM - 11:00 AM	Plane Talk	Ryan Dembroski	Boeing Plaza	L-13	F
10:00 AM - 11:00 AM	Grease Basics and Functions	Andy Dobbins	AeroShell Booth 446/457	L-11	F
10:00 AM - 11:00 AM	Plan for Success 101: System Design	Dynon Staff	Dynon Tent	I-13	F
10:00 AM - 11:00 AM	GE Aerospace: CF34 Fan Maintenance	Jim Condon	GE Aerospace	K-14	F
10:00 AM - 11:00 AM	Pilot Show-and-Tell	AC & Sue Hutson	Charles W. Harris Youth Aviation Center	L-15	F
10:00 AM - 11:00 AM	Mayday: SEL IFR Engine Failure	George Gratton	Vintage Hangar	K-15	F
10:00 AM - 11:15 AM	The Beechcraft T-34 Mentor	Walt Fricke	Warbirds in Review	L-7	F
10:00 AM - 11:15 AM	Flying Start: Growing Participation	David Leiting	EAA Blue Barn Featuring EAA Chapters, EAA Young Eagles, and EAA Eagle Flights	J-9	F
10:00 AM - 11:15 AM	Extend the Life of Your Propeller	Aaron "Opie" Perry	Hartzell Propeller 296-297	J-13	F
10:00 AM - 11:15 AM	Strategies for Winning Scholarships	Peggy Doyle	EAA WomenVenture Center	K-10	F
10:00 AM - 11:15 AM	Aircraft Options for Training	Tim Hoversten	EAA Learn to Fly Center	J-13	F
10:00 AM - 11:15 AM	Airships: Past, Present & Future	Richard Van Treuren	Forum Stage 1: WILCO	K-9	F
10:00 AM - 11:15 AM	NASA's Wicked Works	Keith Wichman	Forum Stage 2: Aero Hose Shop	K-9	F
10:00 AM - 11:15 AM	Ongoing Airworthiness for Zeniths	Matt Heintz	Forum Stage 3: Superflite	K-9	F
10:00 AM - 11:15 AM	Weather Briefs: Tips and Pitfalls	Gary Pokodner	Forum Stage 4: Pilotsmith	J-9	F
10:00 AM - 11:15 AM	Fighter Combat WWII	Steve Church	Forum Stage 6: EnerSys	J-9	F
10:00 AM - 11:15 AM	ForeFlight Fundamentals	ForeFlight	Forum Stage 7: ForeFlight	J-9	F
10:00 AM - 11:15 AM	Minesweeper: Flying the Sea Dragon	Eric Mott	Forum Stage 8: GAMA	J-9	F
10:00 AM - 11:15 AM	Where Is My Flying Car?	Palmer Stiles	Forum Stage 9: SOFTIE PARACHUTES by Para-Phernalia Inc.	J-9	F
10:00 AM - 11:15 AM	Engineering eBeaver From the Sea Up	Blago Hristovski	Forum Stage 10: Poly Fiber Inc.	K-9	F
10:00 AM - 11:15 AM	U.S.-Trained WWII Mosquito Pilot	Colin S. Bell	Forum Stage 11: DeltaHawk Engines	K-9	F
10:00 AM - 11:15 AM	Lycoming Engines EIS Overview	Judson Rupert	Workshop Classroom A	K-10	F
10:00 AM - 11:15 AM	Engine Dehydration = Save Money	Steve Sennett	Workshop Classroom B	K-10	F
10:00 AM - 11:15 AM	Aviation Paint Polishing	Josh Hernandez	Workshop Classroom C	K-10	F
10:00 AM - 11:15 AM	Forming Basics	Mark Kennison	Aeroplane Workshop	L-9	W
10:00 AM - 11:15 AM	Golden Age of Monoplanes	Michael Goulian	International Aerobatic Club (IAC) Aerobatics Center	L-12	F
10:00 AM - 11:15 AM	Letters From a Soviet Prison	Gary Powers Jr.	EAA Museum - Hilton Theater	B-8	F
10:00 AM - 11:15 AM	The Decisions to Drop the A-Bomb	Norm Reynolds	EAA Museum - Skyscape Theater	B-8	F
10:00 AM - 11:15 AM	Atlantic Adventure in Sling HW	Linda Sollars	Homebuilders Hangar Supported by Aircraft Spruce & Specialty	K-9	F
10:00 AM - 11:15 AM	Homebuilts in Review		Homebuilts in Review	K-9	F
10:00 AM - 11:15 AM	Light Sport Repairman Rating	Brian Carpenter	Ultralight Forums Tent	K-18	F
10:15 AM - 11:30 AM	Flying to and From Canada	Ian Brown	EAA Canada	K-12	F
10:15 AM - 12:00 PM	Power Loss at 300 Feet	Philip Mandel	FAA Aviation Safety Center, Flight Service Station	J-11	F
10:30 AM - 11:00 AM	Introducing Airspace Insight	Iain Box	GE Aerospace	K-14	F
10:30 AM - 11:00 AM	Performing Aerobatics at Air Shows	F/O Melissa Burns	ALPA Booth 329	K-14	MG
10:30 AM - 11:15 AM	Wright-Patterson AFB & History	Steve Byington	International Federal Pavilion	I-13	F
10:30 AM - 11:45 AM	Naval Academy and Future Pilots	Mark Germano	EAA AeroEducate Forum Tent	I-10	F

DAILY EVENTS

Sponsored by  AIRCRAFT
WHEEL & BRAKE
BY KAMAN

Cleveland
Wheels & Brakes

TIME	PRESENTATION	SPEAKER	LOCATION	MAP	TYPE
FRIDAY, JULY 26, 2024					
10:45 AM - 12:00 PM	Vintage in Review	Ray Johnson	Rose Plaza Interview Circle	L-14	F
11:00 AM - 11:30 AM	Day in the Life of an Airline Pilot	F/O Justin Dahan	ALPA Booth 329	K-14	FE
11:00 AM - 11:30 AM	First U.S. Jet Engine Comes to Life	Nick Hurm	GE Aerospace	K-14	F
11:00 AM - 11:30 AM	Let Your Pilot Career Take Flight	Southwest Airlines	Southwest Airlines	I-10	F
11:00 AM - 11:45 AM	Essential Guide to UPRRT	Andrea Germanetti	NAFI Booth	J-14	F
11:00 AM - 11:45 AM	Upgrades: The Urgent/Unnecessary	Coflyt	AOPA Program Pavilion	L-11	F
11:00 AM - 12:00 PM	Straighten Up & Fly Right	Greg Roark	Redbird Sim Lab	J-13	F
11:00 AM - 12:00 PM	Cockpit Upgrades on a Budget	Garmin	Garmin Seminar Tent 2	K-13	F
11:00 AM - 12:00 PM	An In-Depth Look at G1 275	Garmin Aviation Team	Garmin Seminar Tent 1	K-13	F
11:00 AM - 12:00 PM	Plane Talk	Ryan Dembroski	Boeing Plaza	L-13	F
11:00 AM - 12:00 PM	The Women With Silver Wings	Katherine Landdeck	EAA Wearhouse	J-12	MG
11:00 AM - 12:00 PM	Select the Best Piston Engine Oil	Piotr Gawecki	AeroShell Booth 446/457	L-11	F
11:00 AM - 12:00 PM	Piper Comanche Forum	CJ Stumpf	Vintage Hangar	K-15	F
11:00 AM - 12:15 PM	ATC & You: Speaking With Confidence	NATCA	NATCA Booth	J-10	F
11:30 AM - 12:00 PM	Landing an Aviation Scholarship	F/O Camila Turrieta	ALPA Booth 329	K-14	FE
11:30 AM - 12:00 PM	COPA Advocacy Update	George Farrington	EAA Canada	K-12	F
11:30 AM - 12:15 PM	Confidence in the Cockpit	Cayla Hunt	EAA WomenVenture Center	K-10	F
11:30 AM - 12:15 PM	TFRs: How to Avoid an Intercept	Lt. Col. Trevor "Boat" Boswell	International Federal Pavilion	I-13	F
11:30 AM - 12:30 PM	Reaching Optimal Engine Performance	Chuck Cook	Continental Aerospace Technologies	J-12	F
11:30 AM - 12:30 PM	ADVANCEDPANEL Ecosystem Expansion	AFS Staff	Dynon Tent	I-13	F
11:30 AM - 12:45 PM	Stop Dreaming, Start Flying	David Leiting	EAA Learn to Fly Center	J-13	F
11:30 AM - 12:45 PM	EAA AeroEducate: Youth Activities	Danielle Schmick	EAA Blue Barn Featuring EAA Chapters, EAA Young Eagles, and EAA Eagle Flights	J-9	F
11:30 AM - 12:45 PM	Maintaining UAS Pilot Proficiency	Kenneth Kranz	Forum Stage 1: WILCO	K-9	F
11:30 AM - 12:45 PM	Pilot's Guide to Award Travel	Jason Steele	Forum Stage 2: Aero Hose Shop	K-9	F
11:30 AM - 12:45 PM	International Flying Gotchas	Rick Gardner	Forum Stage 3: Superflite	K-9	F
11:30 AM - 12:45 PM	Fuel System Basics	Donald Hall	Forum Stage 4: Pilotsmith	J-9	F
11:30 AM - 12:45 PM	Designing the Perfect Paint Scheme	Craig Barnett	Forum Stage 5: Scheme Designers	J-9	F
11:30 AM - 12:45 PM	XC Breakdowns	Mike Busch	Forum Stage 6: EnerSys	J-9	F
11:30 AM - 12:45 PM	Beech and the King Airs	Burt Rutan	Forum Stage 7: ForeFlight	J-9	F
11:30 AM - 12:45 PM	Strip Flying in New Zealand	Matt and Jo McCaughan	Forum Stage 8: GAMA	J-9	F
11:30 AM - 12:45 PM	The Emerging AAM Policy Landscape	Trevor Simoneau	Forum Stage 9: SOFTIE PARACHUTES by Para-Phernalia Inc.	J-9	F
11:30 AM - 12:45 PM	Modernization of the Air Force	Lea Kirkwood	Forum Stage 10: Poly Fiber Inc.	K-9	F
11:30 AM - 12:45 PM	Garmin GPS IFR Pro Tips	Gary Reeves	Forum Stage 11: DeltaHawk Engines	K-9	F
11:30 AM - 12:45 PM	Composite Finishing Techniques	Scott VanderVeen	Workshop Classroom A	K-10	W
11:30 AM - 12:45 PM	Autopilot Install Adventure	Michael Jones	Workshop Classroom B	K-10	F
11:30 AM - 12:45 PM	How to Shine: Part 2	Radara Elkins	Workshop Classroom C	K-10	F
11:30 AM - 12:45 PM	English Wheel	Mark Kennison	Aeroplane Workshop	L-9	W
11:30 AM - 12:45 PM	Why Reporters Get Aviation Wrong	Pete Muntean	International Aerobatic Club (IAC) Aerobatics Center	L-12	F
11:30 AM - 12:45 PM	Gliders: The Airborne's Supply Line	Annemarie Monique Taylor	EAA Museum - Vette Theater	B-8	F
11:30 AM - 12:45 PM	The Man Behind Loving's Love	Eileen Bjorkman	EAA Museum - Hilton Theater	B-8	F
11:30 AM - 12:45 PM	Aviation Photography: Tips & Tricks	Deon Mitton	EAA Museum - Skyscape Theater	B-8	F
11:30 AM - 12:45 PM	LOBO Forum	Robert Pastusek	Homebuilders Hangar Supported by Aircraft Spruce & Specialty	K-9	F
11:30 AM - 12:45 PM	STOL Across the U.S.: Photos	Dr. Robert Jones	Ultralight Forums Tent	K-18	F
11:30 AM - 2:00 PM	Homebuilt Rotorcraft		Fun Fly Zone	K-20	SE
12:00 PM - 12:30 PM	Pathways to the Airlines	F/O Mark Lockwood	ALPA Booth 329	K-14	FE
12:00 PM - 12:45 PM	Choosing the Right Altitude	Hans Gaida	NAFI Booth	J-14	F
12:00 PM - 12:45 PM	Vittorazi Motor Rebuild/Maintenance		Ultralight Workshop Tent	K-18	F
12:00 PM - 12:45 PM	ForeFlight for Pinch Hitters	ForeFlight	AOPA Program Pavilion	L-11	F
12:00 PM - 1:00 PM	Garmin Engine Monitor Solutions	Garmin	Garmin Seminar Tent 2	K-13	F
12:00 PM - 1:00 PM	Meet Air Show Performer Kyle Fowler		EAA Canada	K-12	MG
12:00 PM - 1:00 PM	GNS Transition: Find Your Next GPS	Garmin Aviation Team	Garmin Seminar Tent 1	K-13	F
12:00 PM - 1:00 PM	Plane Talk	Ryan Dembroski	Boeing Plaza	L-13	F
12:00 PM - 1:00 PM	Leadership That Breaks Barriers	John Teichert	EAA Wearhouse	J-12	MG
12:00 PM - 2:00 PM	Prepare/Prevent vs. Repair/Repent	Ramin Panahi	FAA Aviation Safety Center, Flight Service Station	J-11	F
12:00 PM - 5:00 PM	Type Clubs	Charlie Waterhouse	Vintage Hangar	K-15	F

TIME	PRESENTATION	SPEAKER	LOCATION	MAP	TYPE
FRIDAY, JULY 26, 2024					
12:30 PM - 1:00 PM	Military Vets to Airline Jets	Air Line Pilots Association	ALPA Booth 329	K-14	FE
12:30 PM - 1:15 PM	How We Respond to Beacon Activation	Allan Knox	International Federal Pavilion	I-13	F
12:30 PM - 1:45 PM	ATC & You: Real-World Lessons Ch 2	NATCA	NATCA Booth	J-10	F
12:45 PM - 3:15 PM	COPA Safety Seminar: XC Flying	Conrad Hatcher	EAA Canada	K-12	F
1:00 PM - 1:30 PM	Avidyne IFD With iPad/ForeFlight	Randall Edwards	Avidyne Booth 3130A	I-12	F
1:00 PM - 1:30 PM	Catalyst Engine: Beechcraft Denali	Josh Hobson	GE Aerospace	K-14	F
1:00 PM - 1:30 PM	Let Your Pilot Career Take Flight	Southwest Airlines	Southwest Airlines	I-10	F
1:00 PM - 1:45 PM	The Pilot Mindset	David Consbruck	NAFI Booth	J-14	F
1:00 PM - 1:45 PM	How to Build a Career in Aviation	Matt Johnston	AOPA Program Pavilion	L-11	F
1:00 PM - 1:45 PM	Vittorazi Motor Rebuild/Maintenance		Ultralight Workshop Tent	K-18	F
1:00 PM - 2:00 PM	What Makes an Airplane Fly?	Greg Roark	Redbird Sim Lab	J-13	F
1:00 PM - 2:00 PM	How to Plan and Shop for Avionics	Garmin	Garmin Seminar Tent 2	K-13	F
1:00 PM - 2:00 PM	Your Next Autopilot: GFC 500/600	Garmin Aviation Team	Garmin Seminar Tent 1	K-13	F
1:00 PM - 2:00 PM	Up in the Air: A Pilot's Journey	Robert Fulton	EAA Wearhouse	J-12	MG
1:00 PM - 2:00 PM	Plane Talk	Ryan Dembroski	Boeing Plaza	L-13	F
1:00 PM - 2:00 PM	Plan for Success 102: System Design	Dynon Staff	Dynon Tent	I-13	F
1:00 PM - 2:00 PM	GE Aerospace: CF34 Fan Maintenance	Jim Condon	GE Aerospace	K-14	F
1:00 PM - 2:00 PM	Design, Build, Fly: Airplane Sims	Embry-Riddle Aeronautical University	Embry-Riddle Booth 49	J-10	F
1:00 PM - 2:15 PM	Best Path to Becoming a Pro Pilot	Paul Maloy	EAA Learn to Fly Center	J-13	F
1:00 PM - 2:15 PM	Never Rib Stitch or Pop Rivet Again	Siegfried Lanitz	Workshop Classroom B	K-10	F
1:00 PM - 2:15 PM	Online Presence for EAA Chapters	Chris Gauger	EAA Blue Barn Featuring EAA Chapters, EAA Young Eagles, and EAA Eagle Flights	J-9	F
1:00 PM - 2:15 PM	A Salute to Veterans Parade		Warbirds in Review	L-7	SE
1:00 PM - 2:15 PM	GARA at 30	Timothy M. Ravich	Forum Stage 1: WILCO	K-9	F
1:00 PM - 2:15 PM	Inside the Tenerife Crash	Laura Savino	Forum Stage 2: Aero Hose Shop	K-9	F
1:00 PM - 2:15 PM	Choosing a Fabric Covering System	Molly Dean	Forum Stage 3: Superflite	K-9	F
1:00 PM - 2:15 PM	ATC View of In-Flight Emergencies	Dean Brown	Forum Stage 4: Pilotsmith	J-9	F
1:00 PM - 2:15 PM	Spy Pilot	Gary Powers Jr.	Forum Stage 5: Scheme Designers	J-9	F
1:00 PM - 2:15 PM	Obsessed With EGT	Mike Busch	Forum Stage 6: EnerSys	J-9	F
1:00 PM - 2:15 PM	ForeFlight Power Users	ForeFlight	Forum Stage 7: ForeFlight	J-9	F
1:00 PM - 2:15 PM	14-Year-Old Alina's Solo Adventure	Alina and William Scott	Forum Stage 8: GAMA	J-9	F
1:00 PM - 2:15 PM	Living the Lunar Life	Patricia Moore	Forum Stage 9: SOFTIE PARACHUTES by Para-Phernalia Inc.	J-9	F
1:00 PM - 2:15 PM	Fabric Covering 101	EAA SportAir	Forum Stage 10: Poly Fiber Inc.	K-9	W
1:00 PM - 2:15 PM	Drone Delivery in Your Community	Zipline	Forum Stage 11: DeltaHawk Engines	K-9	F
1:00 PM - 2:15 PM	Sheet Metal 101	EAA SportAir Sheet Metal	Sheet Metal Workshop Presented by Aircraft Spruce & Specialty	J-10	W
1:00 PM - 2:15 PM	Composite 101	EAA SportAir Composites	Workshop Classroom A	K-10	W
1:00 PM - 2:15 PM	Wood Construction 101	EAA SportAir Wood	Wood Workshop	K-10	W
1:00 PM - 2:15 PM	Gas Welding 101	EAA SportAir Gas Welding	Gas Welding Workshop	K-10	W
1:00 PM - 2:15 PM	Aircraft Hose	Chelsey Hickey	Workshop Classroom C	K-10	F
1:00 PM - 2:15 PM	Power Hammer	Mark Kennison	Aeroplane Workshop	L-9	W
1:00 PM - 2:15 PM	Flight Quality of the New Integral	Aura-Aero	International Aerobatic Club (IAC) Aerobatics Center	L-12	F
1:00 PM - 2:15 PM	What the (EM)F?!	Margaret Viola	EAA Museum - Vette Theater	B-8	F
1:00 PM - 2:15 PM	Flying the F-117 Stealth Fighter	William O'Connor	EAA Museum - Skyscape Theater	B-8	F
1:00 PM - 2:15 PM	Goose: Your Digital Co-Pilot	Mirko Hahn	Homebuilders Hangar Supported by Aircraft Spruce & Specialty	K-9	F
1:00 PM - 2:15 PM	Homebuilts in Review		Homebuilts in Review	K-9	F
1:00 PM - 2:15 PM	Shooting and Editing Flying Videos	Les Homan	Ultralight Forums Tent	K-18	F
1:00 PM - 2:30 PM	Vintage Children's Workshop	AC & Sue Hutson	Charles W. Harris Youth Aviation Center	L-15	W
1:00 PM - 3:00 PM	Reassembly of a Lycoming Engine	Michael Damiani	Lycoming Engines Booth	J-12	D

DAILY EVENTS

Sponsored by  **AIRCRAFT**
WHEEL & BRAKE
BY KAMAN

Cleveland
Wheels & Brakes

TIME	PRESENTATION	SPEAKER	LOCATION	MAP	TYPE
FRIDAY, JULY 26, 2024					
1:00 PM - 4:00 PM	TIG Welding 101	EAA SportAir TIG Welding	TIG Welding Workshop Presented by Lincoln Electric	K-10	W
1:30 PM - 2:15 PM	Flying to the Bahamas	To Be Announced	International Federal Pavilion	I-13	F
1:30 PM - 2:30 PM	Cleared for Takeoff	James Groat	EAA Seaplane Base Presented by Wipaire Base	Seaplane Base	F
2:00 PM - 2:45 PM	Learning From Icarus	Bruce Landsberg	AOPA Program Pavilion	L-11	F
2:00 PM - 3:00 PM	Choosing a Garmin PFD/MFD	Garmin Aviation Team	Garmin Seminar Tent 1	K-13	F
2:00 PM - 3:00 PM	Building Your Experimental Panel	Garmin	Garmin Seminar Tent 2	K-13	F
2:00 PM - 3:00 PM	Shot Down Over Italy	John Lanza	EAA Wearhouse	J-12	MG
2:00 PM - 3:30 PM	Wow, It's Windy	Greg Roark	Redbird Sim Lab	J-13	F
2:00 PM - 4:00 PM	Perfect Landings	Mike Montefusco	FAA Aviation Safety Center, Flight Service Station	J-11	F
2:15 PM - 6:00 PM	Friday Air Show	EAA	Air Show	M-13	A
2:30 PM - 3:15 PM	Auto Ground Collision Avoidance	To Be Announced	International Federal Pavilion	I-13	F
2:30 PM - 3:45 PM	One Size Does Not Fit All	Megan Biles	EAA WomenVenture Center	K-10	F
2:30 PM - 3:45 PM	Pilot Mental Health Campaign	To Be Announced	Forum Stage 1: WILCO	K-9	F
2:30 PM - 3:45 PM	How to Fix a Failing Airport	Dr. Michael Jones	Forum Stage 2: Aero Hose Shop	K-9	F
2:30 PM - 3:45 PM	Advanced Skew-T Log-P Concepts	Dr. Scott Dennstaedt	Forum Stage 3: Superlite	K-9	F
2:30 PM - 3:45 PM	How Much Is Enough?	Danny Sims	Forum Stage 4: Pilotsmith	J-9	F
2:30 PM - 3:45 PM	BOOM! Innovation on Afterburner	John Teichert	Forum Stage 5: Scheme Designers	J-9	F
2:30 PM - 3:45 PM	A New Lowest-Cost Shared Jet Model	Jay Schrankler	Forum Stage 6: EnerSys	J-9	F
2:30 PM - 3:45 PM	Demystifying Electric Propulsion	Chris Foster	Forum Stage 8: GAMA	J-9	F
2:30 PM - 3:45 PM	Flight With Broken Flight Controls	Gordon Penner	Forum Stage 9: SOFTIE PARACHUTES by Para-Phernalia Inc.	J-9	F
2:30 PM - 3:45 PM	Backcountry Flight Survival Tips	Jim Kasic	Forum Stage 10: Poly Fiber Inc.	K-9	F
2:30 PM - 3:45 PM	Airline Pilot Job Market	Kit Darby III	Forum Stage 11: DeltaHawk Engines	K-9	F
2:30 PM - 3:45 PM	Is the Approach Active?	Hank Gibson	Workshop Classroom A	K-10	F
2:30 PM - 3:45 PM	Gas Welding Aluminum	EAA SportAir Gas Welding	Gas Welding Workshop	K-10	W
2:30 PM - 3:45 PM	Advanced Forming	Mark Kennison	Aeroplane Workshop	L-9	W
2:30 PM - 3:45 PM	Langley & Mechanical Flight	Kip Lankenau	EAA Museum - Hilton Theater	B-8	F
2:30 PM - 3:45 PM	Getting Started in Ultralights	Timm Bogenhagen	Homebuilders Hangar Supported by Aircraft Spruce & Specialty	K-9	F
3:00 PM - 3:45 PM	Airplanes and Social Media	Joe Costanza	AOPA Program Pavilion	L-11	F
3:00 PM - 4:00 PM	The Last of the Wild Horses	Mark Phillips	EAA Wearhouse	J-12	MG
4:00 PM - 4:45 PM	Psychology of Personal Minimums	Jolie Lucas	AOPA Program Pavilion	L-11	F
4:00 PM - 5:00 PM	Flight Lines	Kent Smerdon	EAA Wearhouse	J-12	MG
4:00 PM - 5:15 PM	Jet Boss: Taking Risks	Laura Savino	EAA WomenVenture Center	K-10	F
4:00 PM - 5:15 PM	The Wonderful Warthog, Part 5	Cliff "Tude" Latta	Forum Stage 7: ForeFlight	J-9	F
4:00 PM - 6:00 PM	Who Can Do Homebuilt Maintenance?	Joseph Norris	FAA Aviation Safety Center, Flight Service Station	J-11	F
5:00 PM - 6:00 PM	The Wright Engineers	Brian Page	EAA Wearhouse	J-12	MG
5:30 PM - 6:45 PM	Aviation Photographers Gathering	David Powell	Forum Stage 10: Poly Fiber Inc.	K-9	SE
6:00 PM - 6:30 PM	Rotorcraft Awards		Theater in the Woods Supported by M&M'S	K-15	SE
6:00 PM - 7:00 PM	Jewish Shabbat Service		Chapel and Compass Hill	E-8	CS
6:00 PM - 7:00 PM	Old Glory Honor Flight		Boeing Plaza	L-13	SE
6:00 PM - 10:00 PM	Ultralight Banquet and Awards		VAA Tall Pines Cafe	L-20	SE
7:00 PM - 10:30 PM	NASA: Historic Artemis II Mission		Theater in the Woods Supported by M&M'S	K-15	SE
8:00 PM - 9:45 PM	Twilight Flight Fest		Fun Fly Zone	K-20	SE
8:00 PM - 10:00 PM	Musical Jam Session		Ultralight Forums Tent	K-18	SE
8:30 PM - 9:30 PM	Balloon Glow		Fun Fly Zone	K-20	SE
8:30 PM - 10:45 PM	The Blue Angels		Fly-In Theater Presented by Lycoming	E-13	M

TIME	PRESENTATION	SPEAKER	LOCATION	MAP	TYPE
SATURDAY, JULY 27, 2024					
6:00 AM - 7:00 AM	Balloon Launch		Fun Fly Zone	K-20	SE
7:00 AM - 7:45 AM	Fellowship of the Wing		Chapel and Compass Hill	E-8	CS
7:00 AM - 9:00 AM	Powered Parachutes		Fun Fly Zone	K-20	SE
7:00 AM - 9:30 AM	AirVenture Runway 5K		Ultralight Barn	K-18	SE
8:00 AM - 8:45 AM	Cameras in Aircraft	Dominic Martinez	NAFI Booth	J-14	F
8:00 AM - 9:00 AM	Pilot Training With GFC 500X	Garmin	Garmin Seminar Tent 2	K-13	F
8:00 AM - 9:00 AM	Configuring G3X Touch	Garmin Aviation Team	Garmin Seminar Tent 1	K-13	F
8:00 AM - 9:15 AM	ATC & You: David vs. Goliath	NATCA	NATCA Booth	J-10	F
8:30 AM - 9:30 AM	Can I Run My Engine Lean of Peak?	Chuck Cook	Continental Aerospace Technologies	J-12	F
8:30 AM - 9:45 AM	Learning to Fly Recreationally	Lily Johnson	EAA WomenVenture Center	K-10	F
8:30 AM - 9:45 AM	Aerobatics for Beginners	Budd Davisson	Forum Stage 6: EnerSys	J-9	F
8:30 AM - 9:45 AM	Fabric Covering 101	EAA SportAir	Forum Stage 10: Poly Fiber Inc.	K-9	W
8:30 AM - 9:45 AM	Ask the Weather Expert	Dr. Scott Dennstaedt	Forum Stage 11: DeltaHawk Engines	K-9	F
8:30 AM - 9:45 AM	Sheet Metal 101	EAA SportAir Sheet Metal	Sheet Metal Workshop Presented by Aircraft Spruce & Specialty	J-10	W
8:30 AM - 9:45 AM	Composite 101	EAA SportAir Composites	Workshop Classroom A	K-10	W
8:30 AM - 9:45 AM	Wood Construction 101	EAA SportAir Wood	Wood Workshop	K-10	W
8:30 AM - 9:45 AM	Gas Welding 101	EAA SportAir Gas Welding	Gas Welding Workshop	K-10	W
8:30 AM - 9:45 AM	The Wright Brothers as Engineers	Brian Page	EAA Museum - Vette Theater	B-8	F
8:30 AM - 9:45 AM	The Decisions to Drop the A-Bomb	Norm Reynolds	EAA Museum - Skyscape Theater	B-8	F
8:30 AM - 9:45 AM	ME Build a Plane? YES, YOU CAN!	Tim Hoversten	Homebuilders Hangar Supported by Aircraft Spruce & Specialty	K-9	F
8:30 AM - 10:15 AM	Enhancing Turbulence Info for GA	Tammy Flowe	FAA Aviation Safety Center, Flight Service Station	J-11	F
8:30 AM - 12:00 PM	TIG Welding 101	EAA SportAir TIG Welding	TIG Welding Workshop Presented by Lincoln Electric	K-10	W
8:30 AM - 2:30 PM	Player Special Restoration		Aeroplane Workshop	L-9	D
8:30 AM - 2:30 PM	Fabric Covering Demonstration		Aeroplane Workshop	L-9	D
8:30 AM - 2:30 PM	Cozy Aircraft Build		Aeroplane Workshop	L-9	D
8:30 AM - 2:30 PM	Homebuilders Workshop Acro/Sonex	Aeroplane Workshop Volunteers	Aeroplane Workshop	L-9	D
8:30 AM - 3:45 PM	Zenith Kit Assembly Demonstration		Aeroplane Workshop	L-9	D
9:00 AM - 9:30 AM	3D	Mark Kennison	Aeroplane Workshop	L-9	W
9:00 AM - 9:45 AM	What Accidents Teach Us	Justin Moore	AOPA Program Pavilion	L-11	F
9:00 AM - 9:45 AM	Carburetor Rebuild and Plumbing		Ultralight Workshop Tent	K-18	F
9:00 AM - 9:45 AM	CFI-Filed NASA Reports	Dr. Robert Zeglin	NAFI Booth	J-14	F
9:00 AM - 10:00 AM	Turbine Oil Differences	Andy Mehring	AeroShell Booth 446/457	L-11	F
9:00 AM - 10:00 AM	Intro to Rotax Aircraft Engines	Lauren Burton	Rotax Aircraft Engines Booth	J-12	F
9:00 AM - 10:00 AM	GFC 500X Installation Basics	Garmin Aviation Team	Garmin Seminar Tent 1	K-13	F
9:00 AM - 10:00 AM	Get Started With Garmin Avionics	Garmin	Garmin Seminar Tent 2	K-13	F
9:00 AM - 10:00 AM	Plane Talk	Ryan Dembroski	Boeing Plaza	L-13	F
9:00 AM - 10:00 AM	Halfway Around the World in 40 Days	Kathrin Kaiser	EAA Wearhouse	J-12	MG
9:00 AM - 10:15 AM	U.S. Coast Guard Aviation Careers	Erin Nolan	EAA AeroEducate Forum Tent	I-10	F
9:00 AM - 11:00 AM	On the Grounds & Up	Jerry Burke	EAA Wearhouse	J-12	MG
9:00 AM - 11:30 AM	Ultralights and Lightplanes		Fun Fly Zone	K-20	SE
9:15 AM - 9:30 AM	GE Aerospace Careers Open House	Talent Acquisition - GE Aerospace	GE Aerospace	K-14	MG
9:30 AM - 10:15 AM	Auto Ground Collision Avoidance	To Be Announced	International Federal Pavilion	I-13	F
9:30 AM - 10:30 AM	Wow, It's REALLY Windy	Greg Roark	Redbird Sim Lab	J-13	F
9:30 AM - 10:45 AM	ATC & You: Next-Level Flying	NATCA	NATCA Booth	J-10	F
9:30 AM - 11:30 AM	Lycoming Engine Lubrication Systems	Michael Damiani	Lycoming Engines Booth	J-12	D
10:00 AM - 10:45 AM	Diagnosing & Correcting Errors	Erica Gilbert	NAFI Booth	J-14	F
10:00 AM - 10:45 AM	Opposing Bases Air Traffic Talk	Alpha Golf Romeo Hotel	AOPA Program Pavilion	L-11	F
10:00 AM - 10:45 AM	Carburetor Rebuild and Plumbing		Ultralight Workshop Tent	K-18	F

DAILY EVENTS

Sponsored by  **AIRCRAFT
WHEEL & BRAKE**
BY KAMAN

Cleveland
Wheels & Brakes

TIME	PRESENTATION	SPEAKER	LOCATION	MAP	TYPE
SATURDAY, JULY 27, 2024					
10:00 AM - 11:00 AM	Aircraft Engine at TBO, Now What?	Bill Ross	Superior Air Parts Booth	I-13	F
10:00 AM - 11:00 AM	Garmin Pilot App Tips & Tricks	Garmin	Garmin Seminar Tent 2	K-13	F
10:00 AM - 11:00 AM	VNAV with GTN Xi & GFC 500 Training	Garmin Aviation Team	Garmin Seminar Tent 1	K-13	F
10:00 AM - 11:00 AM	Continental's Guide to Reaching TBO	Tim Owen	Continental Aerospace Technologies	J-12	F
10:00 AM - 11:00 AM	Leadership That Breaks Barriers	John Teichert	EAA Wearhouse	J-12	MG
10:00 AM - 11:00 AM	Plane Talk	Ryan Dembroski	Boeing Plaza	L-13	F
10:00 AM - 11:00 AM	Grease Basics and Functions	Andy Mehring	AeroShell Booth 446/457	L-11	F
10:00 AM - 11:15 AM	Launching Into Aviation Media	Christine Russell	EAA WomenVenture Center	K-10	F
10:00 AM - 11:15 AM	Ray Aviation Scholarships	Erica Rivera	EAA Learn to Fly Center	J-13	F
10:00 AM - 11:15 AM	Introduce RC Into Your EAA Chapter	Kyle Jaracz	EAA Blue Barn Featuring EAA Chapters, EAA Young Eagles, and EAA Eagle Flights	J-9	F
10:00 AM - 11:15 AM	Little Friend P-51	John H. "Lucky" Luckadoo	Warbirds in Review	L-7	F
10:00 AM - 11:15 AM	Career With Piedmont Airlines	Brian diLorenzo	Forum Stage 1: WILCO	K-9	F
10:00 AM - 11:15 AM	Designing & Building Sling Aircraft	Mike Blyth	Forum Stage 2: Aero Hose Shop	K-9	F
10:00 AM - 11:15 AM	Lycoming Engine Installation	Judson Rupert	Forum Stage 3: Superlite	K-9	F
10:00 AM - 11:15 AM	Congressional Town Hall	EAA Govt Advocacy Team	Forum Stage 4: Pilotsmith	J-9	F
10:00 AM - 11:15 AM	Aviation Photography & You	David Powell	Forum Stage 5: Scheme Designers	J-9	F
10:00 AM - 11:15 AM	People, Pilots, and Staying Alive	Lauretta Webb	Forum Stage 6: EnerSys	J-9	F
10:00 AM - 11:15 AM	Teaching & Learning With ForeFlight	ForeFlight	Forum Stage 7: ForeFlight	J-9	F
10:00 AM - 11:15 AM	Avidyne IFD With Portable Devices	Mr. Will Rickert	Forum Stage 9: SOFTIE PARACHUTES by Para-Phernalia Inc.	J-9	F
10:00 AM - 11:15 AM	The Basics of Part 141	Ryan Jeff	Forum Stage 11: DeltaHawk Engines	K-9	F
10:00 AM - 11:15 AM	Never Rib Stitch or Pop Rivet Again	Siegfried Lanitz	Workshop Classroom A	K-10	F
10:00 AM - 11:15 AM	Building Your Dream Airport	Gary Stevens	Workshop Classroom C	K-10	F
10:00 AM - 11:15 AM	Forming Basics	Mark Kennison	Aeroplane Workshop	L-9	W
10:00 AM - 11:15 AM	Spy Pilot	Gary Powers Jr.	EAA Museum - Vette Theater	B-8	F
10:00 AM - 11:15 AM	Build Your Own Super Cub	Charlie Becker	Homebuilders Hangar Supported by Aircraft Spruce & Specialty	K-9	F
10:00 AM - 11:15 AM	Homebuilts in Review		Homebuilts in Review	K-9	F
10:00 AM - 11:15 AM	Sailcloth Installation and Care	Malcom Brubaker	Ultralight Forums Tent	K-18	F
10:15 AM - 11:30 AM	Canadian Airspace 101	Clark Morawetz	EAA Canada	K-12	F
10:15 AM - 12:00 PM	Loss of Control and Fatal Accidents	Ed Verville	FAA Aviation Safety Center, Flight Service Station	J-11	F
10:30 AM - 11:15 AM	A Pilot's Life in Bush Alaska	Kara Hilwig	International Federal Pavilion	I-13	F
10:30 AM - 11:30 AM	Stalls	Greg Roark	Redbird Sim Lab	J-13	F
10:30 AM - 11:45 AM	Navigating Aviation Training Paths	Danielle Schmick	EAA AeroEducate Forum Tent	I-10	F
11:00 AM - 11:30 AM	Let Your Pilot Career Take Flight	Southwest Airlines	Southwest Airlines	I-10	F
11:00 AM - 11:30 AM	Day in the Life of an Airline Pilot	F/O Justin Dahan	ALPA Booth 329	K-14	FE
11:00 AM - 11:45 AM	9 Principles of Light Aircraft	Jason Archer	NAFI Booth	J-14	F
11:00 AM - 11:45 AM	Ask the A&Ps: Live	Mike Busch	AOPA Program Pavilion	L-11	F
11:00 AM - 12:00 PM	Cockpit Upgrades on a Budget	Garmin	Garmin Seminar Tent 2	K-13	F
11:00 AM - 12:00 PM	An In-Depth Look at GI 275	Garmin Aviation Team	Garmin Seminar Tent 1	K-13	F
11:00 AM - 12:00 PM	Plane Talk	Ryan Dembroski	Boeing Plaza	L-13	F
11:00 AM - 12:00 PM	Final Flight, Final Fight and More	Erin Miller	EAA Wearhouse	J-12	MG
11:00 AM - 12:00 PM	Select the Best Piston Engine Oil	Andy Dobbins	AeroShell Booth 446/457	L-11	F
11:00 AM - 12:15 PM	ATC & You: In-Flight Emergencies	NATCA	NATCA Booth	J-10	F
11:30 AM - 12:00 PM	Landing an Aviation Scholarship	F/O Camila Turrieta	ALPA Booth 329	K-14	FE
11:30 AM - 12:00 PM	Flying to and From Canada	Ian Brown	EAA Canada	K-12	F
11:30 AM - 12:15 PM	Evolution of Drones and You	Paul Bryan	International Federal Pavilion	I-13	F
11:30 AM - 12:30 PM	A Pilot's Guide to Logbook Entries	Chuck Cook	Continental Aerospace Technologies	J-12	F
11:30 AM - 12:30 PM	CSN = Can't See Nothin'	Greg Roark	Redbird Sim Lab	J-13	F
11:30 AM - 12:45 PM	MOSAIC (Learn to Fly)	EAA Govt Advocacy Team	EAA Learn to Fly Center	J-13	F

TIME	PRESENTATION	SPEAKER	LOCATION	MAP	TYPE
SATURDAY, JULY 27, 2024					
11:30 AM - 12:45 PM	What the (EM)F?!	Margaret Viola	EAA WomenVenture Center	K-10	F
11:30 AM - 12:45 PM	Winning Youth Flight Scholarships	Ilana Steele	Forum Stage 1: WILCO	K-9	F
11:30 AM - 12:45 PM	Aviation Career: How to Get Started	Matthew Toddun	Forum Stage 2: Aero Hose Shop	K-9	F
11:30 AM - 12:45 PM	National Championship Air Races	Gary Patzke	Forum Stage 3: Superlite	K-9	F
11:30 AM - 12:45 PM	Boldly Breaking Aviation Barriers	Andrea Inmon	Forum Stage 4: Pilotsmith	J-9	F
11:30 AM - 12:45 PM	Industrial Metaverse in A&D	Jacques St-Laurent	Forum Stage 5: Scheme Designers	J-9	F
11:30 AM - 12:45 PM	Airline Pilot Job Search	Kit Darby III	Forum Stage 6: EnerSys	J-9	F
11:30 AM - 12:45 PM	Flying the F-117 Stealth Fighter	William O'Connor	Forum Stage 7: ForeFlight	J-9	F
11:30 AM - 12:45 PM	IFR: Surviving Emergencies	Gary Reeves	Forum Stage 9: SOFTIE PARACHUTES by Para-Phernalia Inc.	J-9	F
11:30 AM - 12:45 PM	Advocating for Aeromedical Reform	Kimberly Williams-Nyberg	Forum Stage 10: Poly Fiber Inc.	K-9	F
11:30 AM - 12:45 PM	MOSAIC for Private & Sport Pilots	Charlie Becker	Forum Stage 11: DeltaHawk Engines	K-9	F
11:30 AM - 12:45 PM	F-86 vs. MiG-15	Chuck Melton	EAA Museum - Vette Theater	B-8	F
11:30 AM - 12:45 PM	Thump-Air 38-HP 4-Stroke Part 103	Scott Skalski	Ultralight Forums Tent	K-18	F
11:30 AM - 2:00 PM	Homebuilt Rotorcraft		Fun Fly Zone	K-20	SE
12:00 PM - 12:30 PM	Pathways to the Airlines	F/O Mark Lockwood	ALPA Booth 329	K-14	FE
12:00 PM - 12:45 PM	Engine-Out Procedures	Collin McDonald	NAFI Booth	J-14	F
12:00 PM - 12:45 PM	Vittorazi Motor Rebuild/Maintenance		Ultralight Workshop Tent	K-18	F
12:00 PM - 12:45 PM	Staying Alive in Your Airplane	Jason Miller	AOPA Program Pavilion	L-11	F
12:00 PM - 1:00 PM	GNS Transition: Find Your Next GPS	Garmin Aviation Team	Garmin Seminar Tent 1	K-13	F
12:00 PM - 1:00 PM	Garmin Engine Monitor Solutions	Garmin	Garmin Seminar Tent 2	K-13	F
12:00 PM - 1:00 PM	Plane Talk	Ryan Dembroski	Boeing Plaza	L-13	F
12:00 PM - 1:00 PM	The Women With Silver Wings	Katherine Landdeck	EAA Wearhouse	J-12	MG
12:00 PM - 2:00 PM	IFR Tools for VFR Pilots	Tom Slater	FAA Aviation Safety Center, Flight Service Station	J-11	F
12:30 PM - 1:00 PM	Military Vets to Airline Jets	Air Line Pilots Association	ALPA Booth 329	K-14	FE
12:30 PM - 1:15 PM	TFRs: How to Avoid an Intercept	Lt. Col. Trevor "Boat" Boswell	International Federal Pavilion	I-13	F
12:30 PM - 1:45 PM	ATC & You: Real-World Lessons Ch 3	NATCA	NATCA Booth	J-10	F
12:45 PM - 2:00 PM	eAPIS and CANPASS: How to File	Jim Bell	EAA Canada	K-12	F
1:00 PM - 1:30 PM	GNS-to-IFD Retrofit in Experimental	Will Rickert	Avidyne Booth 3130A	I-12	F
1:00 PM - 1:30 PM	Let Your Pilot Career Take Flight	Southwest Airlines	Southwest Airlines	I-10	F
1:00 PM - 1:45 PM	AI Weather Simulation	Chris Johnson	NAFI Booth	J-14	F
1:00 PM - 1:45 PM	The History of eVTOL	Zachary Reeder	AOPA Program Pavilion	L-11	F
1:00 PM - 1:45 PM	Vittorazi Motor Rebuild/Maintenance		Ultralight Workshop Tent	K-18	F
1:00 PM - 2:00 PM	Your Next Autopilot: GFC 500/600	Garmin Aviation Team	Garmin Seminar Tent 1	K-13	F
1:00 PM - 2:00 PM	How to Plan and Shop for Avionics	Garmin	Garmin Seminar Tent 2	K-13	F
1:00 PM - 2:00 PM	Plane Talk	Ryan Dembroski	Boeing Plaza	L-13	F
1:00 PM - 2:00 PM	Jet Boss: Taking Risks	Laura Savino	EAA Wearhouse	J-12	MG
1:00 PM - 2:00 PM	Rotax Injected Installation Info	Dean Vogel	Rotax Aircraft Engines Booth	J-12	F
1:00 PM - 2:15 PM	How to Use Flight Sims for Training	Josh Harnagel	EAA Learn to Fly Center	J-13	F
1:00 PM - 2:15 PM	Women of Artemis Panel	Patricia Moore	EAA WomenVenture Center	K-10	F
1:00 PM - 2:15 PM	Fairchild PT-26	Kevin Korterud	Warbirds in Review	L-7	F
1:00 PM - 2:15 PM	Pilot Resume & Application Process	Kit Darby III	Forum Stage 1: WILCO	K-9	F
1:00 PM - 2:15 PM	What Is an Aircraft Dispatcher?	Christopher Snyder	Forum Stage 2: Aero Hose Shop	K-9	F
1:00 PM - 2:15 PM	Aircraft Buying/Selling Pitfalls	EAA Legal Advisory Council	Forum Stage 3: Superlite	K-9	F
1:00 PM - 2:15 PM	TBO 5000!	Mike Busch	Forum Stage 6: EnerSys	J-9	F
1:00 PM - 2:15 PM	ForeFlight for Flight Sims	ForeFlight	Forum Stage 7: ForeFlight	J-9	F
1:00 PM - 2:15 PM	Fabric Covering 101	EAA SportAir	Forum Stage 10: Poly Fiber Inc.	K-9	W
1:00 PM - 2:15 PM	Sheet Metal 101	EAA SportAir Sheet Metal	Sheet Metal Workshop Presented by Aircraft Spruce & Specialty	J-10	W
1:00 PM - 2:15 PM	Composite 101	EAA SportAir Composites	Workshop Classroom A	K-10	W
1:00 PM - 2:15 PM	Wood Construction 101	EAA SportAir Wood	Wood Workshop	K-10	W

DAILY EVENTS

Sponsored by  **AIRCRAFT**
WHEEL & BRAKE
BY KAMAN

Cleveland
Wheels & Brakes

TIME	PRESENTATION	SPEAKER	LOCATION	MAP	TYPE
SATURDAY, JULY 27, 2024					
1:00 PM - 2:15 PM	Gas Welding 101	EAA SportAir Gas Welding	Gas Welding Workshop	K-10	W
1:00 PM - 2:15 PM	Advanced Forming	Mark Kennison	Aeroplane Workshop	L-9	W
1:00 PM - 2:15 PM	Paragliding Regulations & Law	Jonathan Eisele	Ultralight Forums Tent	K-18	F
1:00 PM - 3:00 PM	Reassembly of a Lycoming Engine	Michael Damiani	Lycoming Engines Booth	J-12	D
1:00 PM - 3:45 PM	Bridge of Spies	Gary Powers Jr.	EAA Museum - Skyscape Theater	B-8	M
1:00 PM - 4:00 PM	TIG Welding 101	EAA SportAir TIG Welding	TIG Welding Workshop Presented by Lincoln Electric	K-10	W
1:30 PM - 2:15 PM	Center Weather Service Unit Ops	Greg Master	International Federal Pavilion	I-13	F
1:30 PM - 4:00 PM	Redbird Challenge Cup	Greg Roark	Redbird Sim Lab	J-13	F
2:00 PM - 2:45 PM	Is the Approach Active?	Hank Gibson	AOPA Program Pavilion	L-11	F
2:00 PM - 3:00 PM	Building Your Experimental Panel	Garmin	Garmin Seminar Tent 2	K-13	F
2:00 PM - 3:00 PM	Choosing a Garmin PFD/MFD	Garmin Aviation Team	Garmin Seminar Tent 1	K-13	F
2:00 PM - 3:00 PM	Shot Down Over Italy	John Lanza	EAA Warehouse	J-12	MG
2:00 PM - 4:00 PM	Instrument Departures: SIDs & ODPs	Ed Verville	FAA Aviation Safety Center, Flight Service Station	J-11	F
2:15 PM - 6:00 PM	Saturday Air Show	EAA	Air Show	M-13	A
2:30 PM - 3:15 PM	Aerial Data Collection in Alaska	Kara Hilwig	International Federal Pavilion	I-13	F
2:30 PM - 3:45 PM	First Female Seaplane Pilot in AU	Cathy Babis	EAA WomenVenture Center	K-10	F
2:30 PM - 3:45 PM	Gas Welding Aluminum	EAA SportAir Gas Welding	Gas Welding Workshop	K-10	W
2:30 PM - 3:45 PM	Power Hammer	Mark Kennison	Aeroplane Workshop	L-9	W
3:00 PM - 4:00 PM	Up in the Air: A Pilot's Journey	Robert Fulton	EAA Warehouse	J-12	MG
3:30 PM - 4:15 PM	Flying to the Bahamas	To Be Announced	International Federal Pavilion	I-13	F
4:00 PM - 5:00 PM	The Last of the Wild Horses	Mark Phillips	EAA Warehouse	J-12	MG
4:00 PM - 6:00 PM	What Went Wrong? Pilot Factor in Wx	Dr. Ian Johnson	FAA Aviation Safety Center, Flight Service Station	J-11	F
6:00 PM - 7:00 PM	Catholic Mass		Forum Stage 7: ForeFlight	J-9	CS
6:00 PM - 7:00 PM	Vintage Awards Ceremony		Vintage Hangar	K-15	F
6:30 PM - 7:30 PM	Ultralights and Lightplanes		Fun Fly Zone	K-20	SE
6:30 PM - 7:30 PM	EAA Homebuilt Awards Ceremony	EAA Homebuilt Awards	Homebuilders Hangar Supported by Aircraft Spruce & Specialty	K-9	SE
6:30 PM - 10:30 PM	USAF Materiel Command & Test Pilots		Theater in the Woods Supported by M&M'S	K-15	SE
7:30 PM - 8:00 PM	Powered Parachutes		Fun Fly Zone	K-20	SE
8:00 PM - 10:00 PM	Saturday Night Air Show	EAA	Air Show	M-13	A
8:30 PM - 10:45 PM	The Right Stuff		Fly-In Theater Presented by Lycoming	E-13	M
SUNDAY, JULY 28, 2024					
8:00 AM - 9:15 AM	ATC & You: Speaking With Confidence	NATCA	NATCA Booth	J-10	F
8:30 AM - 9:00 AM	Nondenominational Service		Chapel and Compass Hill	E-8	CS
8:30 AM - 9:45 AM	Fabric Covering 101	EAA SportAir	Forum Stage 10: Poly Fiber Inc.	K-9	W
8:30 AM - 9:45 AM	Sheet Metal 101	EAA SportAir Sheet Metal	Sheet Metal Workshop Presented by Aircraft Spruce & Specialty	J-10	W
8:30 AM - 9:45 AM	TIG Welding 101	EAA SportAir TIG Welding	TIG Welding Workshop Presented by Lincoln Electric	K-10	W
8:30 AM - 9:45 AM	Composite 101	EAA SportAir Composites	Workshop Classroom A	K-10	W
8:30 AM - 9:45 AM	Wood Construction 101	EAA SportAir Wood	Wood Workshop	K-10	W
8:30 AM - 9:45 AM	Gas Welding 101	EAA SportAir Gas Welding	Gas Welding Workshop	K-10	W
9:15 AM - 9:30 AM	GE Aerospace Careers Open House	Talent Acquisition - GE Aerospace	GE Aerospace	K-14	MG
9:15 AM - 10:00 AM	Protestant Service		Theater in the Woods Supported by M&M'S	K-15	CS
9:30 AM - 10:45 AM	ATC & You: Clouds That Fool You	NATCA	NATCA Booth	J-10	F
10:00 AM - 11:00 AM	Memorial Wall Induction Ceremony		Memorial Wall	D-8	SE
10:15 AM - 11:15 AM	Catholic Mass		Theater in the Woods Supported by M&M'S	K-15	CS
11:00 AM - 11:30 AM	Let Your Pilot Career Take Flight	Southwest Airlines	Southwest Airlines	I-10	F
1:00 PM - 1:30 PM	Let Your Pilot Career Take Flight	Southwest Airlines	Southwest Airlines	I-10	F
1:00 PM - 4:30 PM	Sunday Air Show	EAA	Air Show	M-13	A

LOCAL ADVERTISING

EAA welcomes you to Oshkosh and encourages AirVenture visitors to patronize these local businesses while you are in the area.



BECKETS LOCAL



HAPPY HOUR
3-6
DAILY

LIVE JAZZ
WED. 7-9

MODERN DINING IN DOWNTOWN OSHKOSH
OUTDOOR PATIO ON THE FOX RIVER

OPEN DAILY AT 11AM

RESERVATIONS RECOMMENDED
920.230.3333 BECKETSRESTAURANT.COM



WHILE YOU'RE HERE...
EAT LOCAL

100+ WI CHEESES
40 FLAVORS HANDMADE BRATS
500+ CRAFT BEERS
SCRATCH DELI
AGED STEAKS & MORE

YES WE HAVE
SPOTTED COW!

WAGNER MARKET

DOWNTOWN OSHKOSH LOCAL GROCERY

WMGROCER.COM

920.230.MEAT

EXPERIENCE STEAK PERFECTION AT OSHKOSH'S TOP STEAKHOUSE

PRIME DRY AGED BEEF

Wine Spectator



AWARD
OF
EXCELLENCE

2023







TJ's Highland
STEAKHOUSE

LOCATED AT THE
OSHKOSH COUNTRY CLUB!

THE AIRSHOW IS VISIBLE
FROM OUR PATIO!

For Reservations:  OpenTable™

-  5 miles from AirVenture
-  Luxurious seating and atmosphere
-  Open for lunch and dinner
-  Extensive wine and spirits list

**Excellence is never by accident. It is the product of vision, planning,
hard work, experience and care.**



11 W. Ripple Ave.
Oshkosh, WI 54902
1.920.231.1076

The Oshkosh Country Club offers a brand-new Event Center, Private Dining, or a Semi-Private Dining experience to accommodate your event. Our Event Center can host up to 275 guests.

oshkoshcc.com
tjshighlandsteakhouse.com



everything but ordinary...

dream

year-round adventure.



dine

food and drink
to match every
desire.



discover

accessible, affordable
+ fun: Oshkosh.



Check it all
out & make
plans now.

oshkosh

DiscoverOshkosh.com



FREEDOM
foods

HOME TO EAA AIRVENTURE'S
WORLD FAMOUS

DONUTS!!!

Serving Daily at
Classic Concessions

Located on Wittman Road next to
the I.A.C. Headquarters.

Made Fresh Daily on Site

Also available at our other locations:

- Aviation Center
- Kidventure
- North 40 Cafe



**National
Railroad
Museum**

**Historic Trains | Exhibits
Train Rides | Fun For All**



**2285 S. Broadway, Green Bay, WI 54304
(920) 437-7623 | nationalrrmuseum.org**

• **Only 45 minutes north of the EAA** •

EXPERIENCE OSHKOSH'S ONLY CRAFT DISTILLERY

Follow on Facebook for daily drink specials

Weds. 7/24 Live Music on the patio 6-8PM

New WWII themed spirits release

Special hours Noon - 10PM



**STURGEON
SPIRITS**



2663 Oregon Street Oshkosh, WI sturgeonspirits.com

< 20 miles away and admission **FREE** at
Bergstrom-Mahler Museum of Glass:

MOLTEN

30 YEARS OF
AMERICAN STUDIO GLASS



CHEERS!

Remarkable Goblets from
the Boroff Collection



Feathered Friends:
Birds in Glass



...and come back Saturday, August 10
for the nation's only
outdoor all-glass art event:

GILASSS
ARTS FESTIVAL



165 NORTH PARK AVENUE | NEENAH, WI 54956 | BMMGLASS.COM



Here at Culver's®, we serve ButterBurgers® with real Wisconsin cheese and craft our special Wisconsin treat - Fresh Frozen Custard. They're always made with a smile because we're happy to help make your day.

FRESH FROZEN CUSTARD



THE DELUXE BUTTERBURGER®



WISCONSIN CHEESE CURDS



Just 1 mile away!

YOUR LOCAL CULVER'S RESTAURANT:

Culver's of Oshkosh
1580 S Koeller St, Oshkosh, WI 54902

CULVERS.COM

VISIT LACLARE!

CHEESE TASTING • CAFE
 RETAIL STORE • VISITOR CENTER
 MONTHLY EVENTS • GOATS

Our creamery is Wisconsin's home for premier goat cheeses.

Today, we have reached new heights
 as a one-of-a-kind family destination.

Mention this ad at checkout and receive 10% off your in-store purchase!



W2994 County Rd HH | Pipe, WI | Southeast side of Lake Winnebago
 Please check our website for current hours
laclarefamilycreamery.com



Hangar C
 Booth #3168



The coffee company helping our historic aircraft stay in the sky.



DULUTH
TRADING
co

FLY BUCK NAKED

FOR A LIMITED TIME



IN BOTH MEN'S AND
WOMEN'S STYLES



**JET OVER TO OUR EAA BOOTH
AND PURCHASE A PAIR WHILE SUPPLIES LAST**

BOOTH 3072 | HANGAR C

Buck Naked® Underwear is already built with wicking comfort to keep you soaring through the day. Now you can grab some in an all-new, limited-edition Fly Buck Naked Print — in both men's and women's styles, so you can coordinate with your copilot. Get 'em fast — these are flying out of here!

CHECK OUT ALL OUR GEAR ONLINE OR AT OUR 60+ STORES, INCLUDING
1132 S. KOELLER ST., OSHKOSH, WI • 920-376-9235

DULUTHTRADING.COM |   @DULUTHTRADINGCOMPANY

Check out
our New
Model



Pick One Up Today.

HONDA

Quiet • Portable • Fuel Injected

Fly Market
Booth #760

FREE set-up and
local delivery

KITZ & PFEIL
Power Equipment
CENTER

451 N. Main St. Oshkosh

920.236.3350

Please read the owner's manual before operating your Honda Power Equipment and never use in a closed or partly enclosed area where you could be exposed to carbon monoxide. Connection of a generator to house power requires a transfer device to avoid possible injury to power company personnel. Consult a qualified electrician. ©2011 American Honda Motor Co., Inc

05375725

Gifts for ALL Occasions • OPEN ALL YEAR ROUND!

**Kristmas Kringle
Shoppe** LTD.



1330 S. Main St.,
Fond du Lac, WI

(920) 922-3900

Open: Daily 10am-5pm

kristmaskringle.com

HWY 41, EXIT 95 TO MAIN ST.



DAILY SPECIALS



2065 WITZEL AVE
OSHKOSH, WI 54904

(920)385-4414
COZUMELWI.COM

NEW LOCATION
COMING SOON!
1111 WESTOWNE DR
NEENAH, WI 54956

GLOW

IN THE

Park

INDOOR MINI GOLF
& PINBALL ARCADE

15+
PINBALL
MACHINES

18 HOLE
INDOOR BLACKLIGHT
MINI GOLF COURSE
& PINBALL ARCADE!

SKIP THE WAIT, BOOK YOUR TEE TIME ONLINE!

-ONLY 3 MILES FROM EAA GROUNDS-
WWW.GLOWINTHEPARKKOSH.COM

crumbl oshkosh

2241 Westowne Ave.

Visit Us!

Order in-store or in our app!



crumbl





*Taste the legacy.
Embrace the craft.*

STONEARCHBREW PUB.COM

VISIT US AT



BREW PUB

Beer brewed on site,
full-menu restaurant and taproom
and dog-friendly beer garden.

1004 South Olde Oneida St.
Appleton, WI 54915

(920) 731-3322



TIED HOUSE

Weekly brunch menu,
full menu restaurant and bar
and dog-friendly beer garden.

137C West Main St.
Little Chute, WI 54140

(920) 241-8433

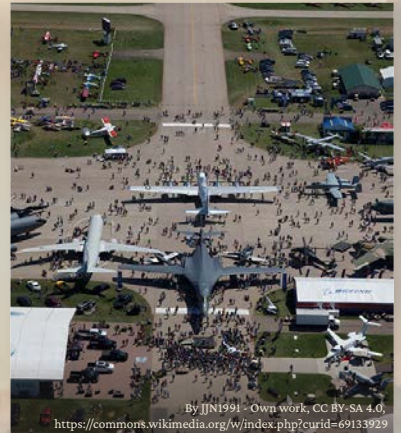

By JJN1991 - Own work, CC BY-SA 4.0,
<https://commons.wikimedia.org/w/index.php?curid=69133929>

OUTER MARKER

Food and tap beer
served daily at our booth
located off James Ray Blvd.

FINAL APPROACH GOLDEN ALE

Pick up your six pack of EAA's exclusive
beer for this year's event. Proudly brewed
by Stone Arch Brewpub in Appleton, WI.



or visit us online at

STONEARCHBREW PUB.COM

Your Pilot Career Starts Here!

Professional Flight Training



GREEN BAY
APPLETON
MILWAUKEE

WWW.PILOTSMITH.COM

Booth 44



WE SELL FUN!



WE MAKE SERVICE EASY!

We make it easy with **onsite service!**

We service all brands and types of RV's
RVIA Certified Factory Trained Technicians



YOUR PREMIER RV DEALER

- Classic Motorized • Motorhomes
- Travel Trailers • Fifth Wheels
- Pop Up Campers • Toy Haulers
- Destinations Trailers



2100 N. MCCARTHY RD., APPLETON
www.appletoncamping.com

920-757-6112



TJ'S HARBOR RESTAURANT

7098 S US 45, OSHKOSH, WI 54902 920-688-9047

Newly renovated patio, wood fired pizzas, expanded dining experience.



EAA Young Eagles

2024 YOUNG EAGLES® RAFFLE

2024 Ford Mustang GT Coupe Premium

\$100 per ticket | Only 1,500 tickets available

Proceeds support the youth education activities of EAA®, including EAA's Young Eagles program, which has provided more than 2.3 million youths with a free first flight since 1992.

The 2024 Ford Mustang is provided with the support of Kocourek Ford, Wausau, Wisconsin.



*Tickets can be purchased: (a) at the EAA Aviation Museum™ between 10:00 a.m. and 5:00 p.m. daily (excluding holidays or when the Museum is closed) throughout the Raffle Period; (b) throughout Wisconsin at certain events during the Raffle Period; and (c) on the EAA® AirVenture® Oshkosh™ grounds during normal operating hours starting on Monday, July 22, 2024 with all sales concluding on Sunday, July 28, 2024 at 12:00 p.m. CT. The drawing will be held at 2:30 p.m. CT on Sunday, July 28, 2024 at the AirVenture Welcome Center, EAA® AirVenture® Oshkosh™, 3000 Poberezny Road, Oshkosh, Wisconsin 54902.



WELCOME

EAA[®] AirVenture[®] Oshkosh[™]
Attendees



**Come see us at the Homebuilt and
Forum Concession Area on the grounds
of Air Venture 2024**

106 Frances Lane
Beaver Dam, WI 53916-1167
920-219-9094

4017 State Highway 28
Sheboygan, WI 53085-2848
920-802-1003

5530 N. Port Washington Rd.
Glendale, WI 53217-4920
414-800-4944

1169 West Winneconne Ave.
Neenah, WI 54956-3693
920-215-6431

1694 S. Koeller Street
Oshkosh, WI 54902-6166
920-385-1006

221 North Peters Avenue
Fond du Lac, WI 54935-2225
920-933-2108

Parker John's BBQ & PIZZA

OPEN
7 DAYS
A WEEK!

smokin' good ribs, wings, & pizza



- ALL DAY HAPPY HOUR
- FULL SERVICE
- OUTDOOR DINING
- 10 MIN FROM AIRVENTURE

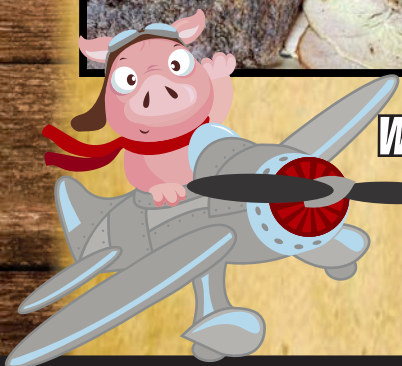

*With Airventure Concession
Stands located at the
Ultralight Cafe
& Tailwinds Cafe*



**30 WISCONSIN ST. OSHKOSH
920-230-2900**

Concession Stand Menu



ELSEWHERE

OSHKOSH, WI

OPEN EAA WEEK | TUES-SUN 7AM-3PM
FT. THEMED DRINK FLIGHTS & IN-STORE SPECIALS

DOWNTOWN OSHKOSH, WI 531 N MAIN ST.

THEELSEWHEREMARKET.COM



GERMAN BIER HALL-STYLE EVENT || JULY 25 || 6-11PM
EAA COCKTAIL HOUR | JULY 26 | 4-8PM
FT., EAA-THEMED DRINK SPECIALS & SPECIALTY COCKTAILS

DOWNTOWN OSHKOSH, WI 537 N MAIN ST.

GIBSONSOCIALCLUB.COM

LAMERS DAIRY

A Wisconsin Family Tradition

One-stop shopping for Dairyland's Best



EAA SPECIAL

20% OFF
Lamers Dairy
entire purchase

with your 2024 EAA wristband

(Valid during EAA 2024 - July 22, 2024 to July 28, 2024)

About 25 miles north of EAA, HWY 441 & CE in Appleton • 920-830-0980
N410 Speel School Road, Appleton, WI 54915 • Store hours: M-F 8-6, Sat. 9-5

A Family Tradition Since 1913 • www.lamersdairyinc.com



check out
our full
menu



**GABES WISCONSIN
KITCHEN AND TAVERN**

WWW.GABESWI.COM

920-230-2818

**1160 N WESTHAVEN DR.
OSHKOSH, WI 54904**

Dinner Features

Campfire Walleye

Garlic Herb Butter, Bacon Creamed
Corn, Roasted Yukons, Haystacks

Stuffed Pork Tenderloin

Broccoli and Spinach Stuffed
Tenderloin, Bacon Cheddar Risotto,
Garlic Cheddar Sauce, Seasonal
Vegetable

Blackberry Sockeye Salmon Salad

Sauteed Salmon, Blackberries,
Blueberries, Goat Cheese,
Fried Garbonzo, Sweet Blackberry
Vinaigrette

Oscar Stuffed Beef Tenderloin

Asparagus and Crab Stuffed
Tenderloin, Hollandaise, Seasonal
Vegetable, Yukon Mashed Potatoes

Wisconsin 5 Cheese Brisket Mac

Slow Braised Brisket, Swiss,
American, Pepper Jack, Parmesan,
and Goat Cheese Mac and Cheese

Cowboy Ribeye

16oz Bone-In Ribeye, Garlic Herb
Butter, Seasonal Vegetable,
Yukon Mashed Potatoes

From Scratch From Wisconsin

EAA SPECIALS



**BETTER INGREDIENTS.
BETTER PIZZA.®**

BETTER *GET YOU SOME* **SOME**
PAPA JOHN'S

\$8.99

**ONE LARGE
ONE TOPPING**

**PROMO CODE
EAA899**

25%

**OFF REGULAR
MENU PRICE**

**PROMO CODE
EAA25**

July 20-July 28



Offer good online only for regular menu price items for a limited time at participating Papa John's restaurants. Not valid with coupons, discounts or promotional prices. Limited delivery area. Delivery fee may apply and is not subject to discount offer. Customer responsible for all applicable taxes. ©2024 Papa John's International, Inc. All Rights Reserved.

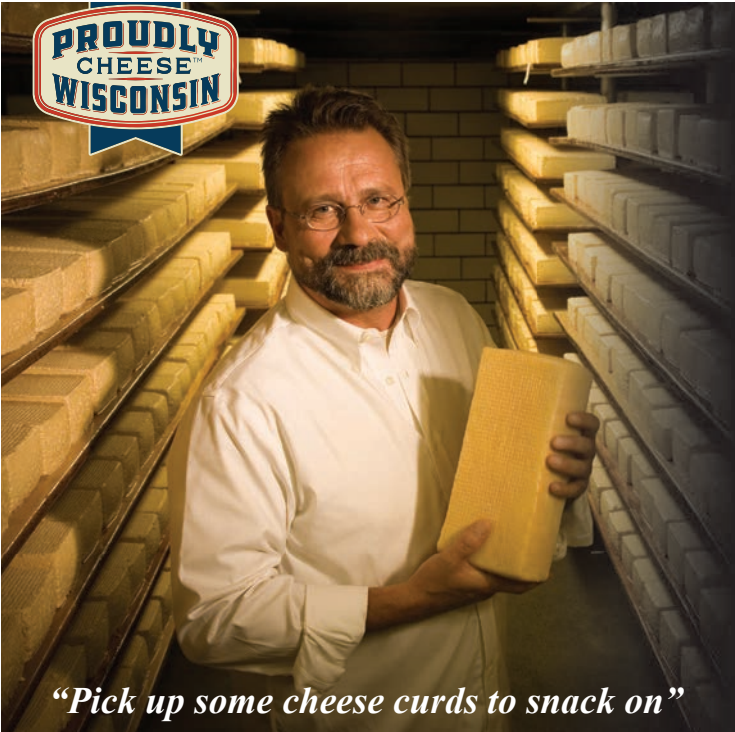

"Pick up some cheese curds to snack on"

10% OFF
orders over \$30
when you show us your
AirVenture wristband
or EAA Camping Credentials

Over 70 Varieties
of Cheese & Sausage
in our Retail Store!

Come and watch us make cheese
from our retail store!

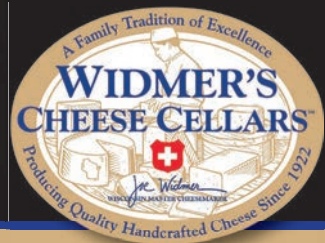

214 W. Henni St.
Theresa, WI, 53091

920-488-2503 or
1-888-878-1107

Store Hours: Mon-Sat: 7am-5pm
Sun: (June-Oct.) 10am-4pm

www.widmerscheese.com

LEDGEROCK DISTILLERY

FROM SEED TO SPIRIT



Visit • Taste • Tour • Shop

FARM DISTILLED SPIRITS



10% Discount on any Spirits Purchased with an EAA Wristband

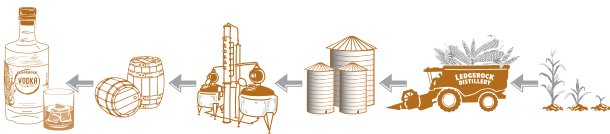

N5287 Grandview Road
Fond du Lac, WI 54937
On the corner of H and Grandview Road

Wednesday - Thursday: 11-5 | Friday - Saturday: 11 - 7 | *Non Regular Hours by Appointment*

LedgerrockDistillery.com | 920-238-9588

PASSION SOARS

Eco-Drive | Purposeful Power

 **PROMASTER**



PROMASTER SNOWBIRDS SKYHAWK A-T

CITIZEN

**Miller
Clock**



Service & Sales inc.

Clocks • Watches • Gifts • Engraving

HANGER A BOOTH 1062

Find your *original* experience



Just 20 minutes north
of the EAA grounds!

Request a free copy
of our Destination
Guide at [FoxCities.org](https://www.FoxCities.org)



GREATER
FOX
CITIES
APPLETON WI

GOOD TIMES. GOOD FOOD. AT EAA AIRVENTURE.

BURGERS • BRATS • CHICKEN • SALADS • FRESH DONUTS
BREAKFAST • KID'S MEALS • MEMBER MEALS

Famous
Wisconsin
White Cheddar
Cheese Curds



SERVING 4 LOCATIONS AT EAA!
CLASSIC . HANGAR B . TOWER . FLY MARKET

VISIT US IN OSHKOSH!
2187 W. 9th Ave., Oshkosh, WI



Chicken not available at Fly Market & Hangar B booths. ©2017 A&W Restaurants, Inc.

*Experience Our
Award Winning
Cheeses*

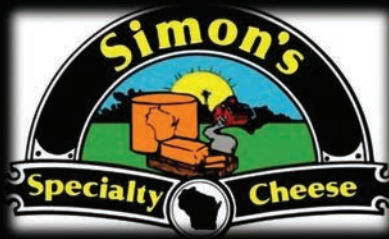

*Pizza, Fudge,
Beer, Gifts &
More!*



(920) 788-6311 | www.simonscheese.com

2735 Freedom Rd., Appleton, WI

Hours: Monday-Friday 8am-6pm; Saturday 8am-4pm



American Eagle® aircraft operated by Air Wisconsin

Taking Flight Since 1965 ***Established in the Fox Cities***

Find your next role with Air Wisconsin. We're hiring for multiple positions in departments working above and below the wing, as well as opportunities at our headquarters in Appleton, WI.

Stop by our booth at
EAA AirVenture

BOOTH C1

Explore Your Future Career
www.airwis.com

Visit us in Hangar C - Booth 3087



EXPERTS IN WHEEL & BRAKE TECHNOLOGY

Aircraft manufacturers worldwide have come to rely on products from Aircraft Wheel & Brake by Kaman.

Cleveland Wheels & Brakes product lines have over 80 years of safe takeoffs and landings to our credit, making us one of the world's most experienced, recognizable, and respected wheel and brake manufacturers.

Cleveland Wheels & Brakes

- The gold standard of braking solutions for certified and experimental aircraft.
- Continued supporter of educational seminars, IA Renewals, and KidVenture.
- Long-time supporter and EAA Member.



Cleveland
Wheels & Brakes